



There when you need us most

EZ Series

Cast Iron and Stainless Steel Booster Pump

Maintenance & Repair Manual

Cast Iron

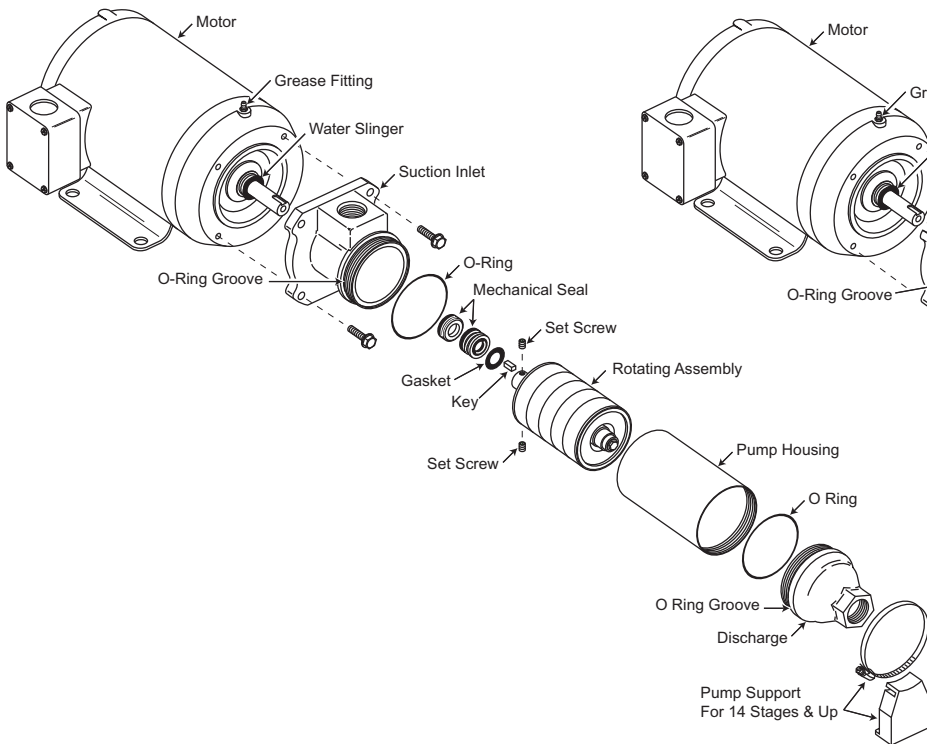

Stainless Steel

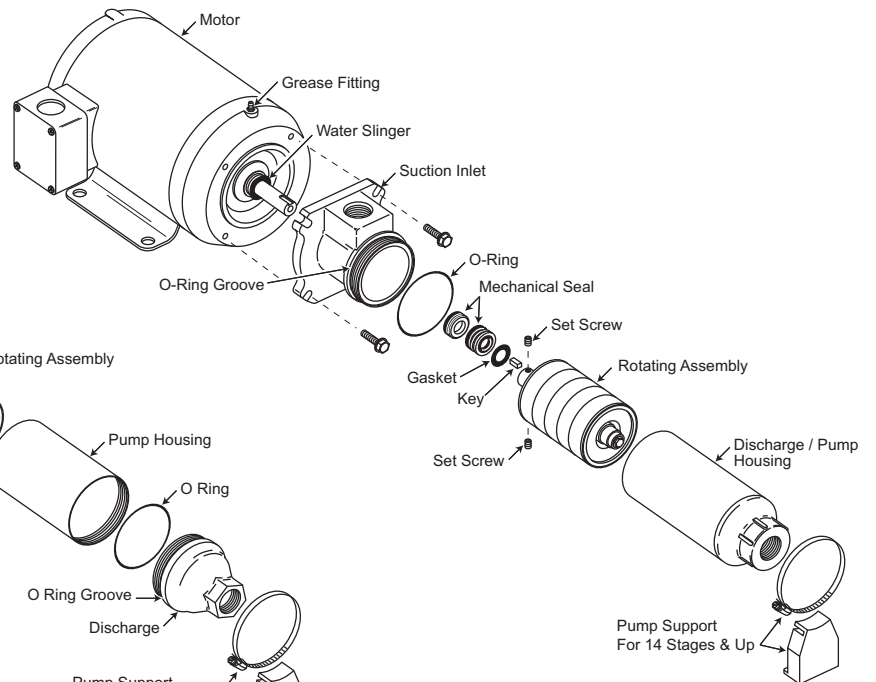

The following information applies to both cast iron and stainless steel 5 HP models.

Warning: Always disconnect the electrical supply prior to servicing the pump.

Removal of Rotating Assembly (RA)

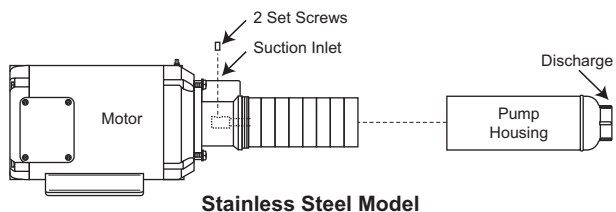
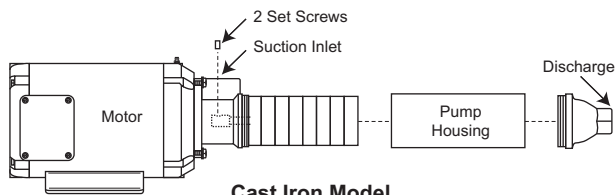

Proceed as follows:

1. Loosen set screws in pump shaft coupling.
2. **Date code: 7-93 to present -**
Cast iron - rotate discharge clockwise (left hand threads) while holding pump housing with a strap wrench. Then, remove the pump housing by rotating it clockwise with a strap wrench.
Stainless steel - rotate welded discharge/pump housing clockwise (left hand threads) with a strap wrench.
Date code: Prior to 7/93 - Rotate discharge counter-clockwise (right hand threads).
3. Remove the top diffuser containing the brass or rulon (maroon) bearing. The top impeller will be exposed.
4. Grasp the SS shaft sleeve bearing and pull RA away from the motor. (Care should be taken not to damage the SS shaft sleeve bearing). If a pair of pliers is needed to grasp the bearing, use some kind of protective covering around the bearing. On longer stage pumps, it might be necessary to squirt 3-in-1 oil into the hole used for the set screw in the pump shaft coupling - if this is done allow the oil to set overnight. Then, insert a screwdriver into the suction inlet hole and pry the pump shaft coupling off the motor shaft:

at the same time, pull the RA away from the motor. You may have to apply a back and forth motion to loosen the coupling from the motor shaft.

Installation of Rotating Assembly (RA)

1. A) Cast iron models - Slide a new o-ring over the threads on the suction inlet and discharge. Position it in the groove up against the shoulder and lubricate the o-ring with a FDA approved lubricant. Lubricate the threads on the suction inlet and discharge with Anti-Seize Lubricating Compound (Part # 41003) or equivalent.

B) Stainless steel models - Repeat item 1.A for the suction inlet.

2. Position the bottom plate of the rotating assembly against the bottom diffuser. When properly installed, you will be able to feel a raised hub and a 1/8" diameter pin on the surface opposite the part number.

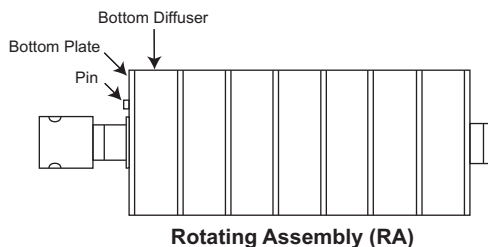

Note: If improperly installed, a 1/8" gap will exist between the bottom plate and diffuser.

3. Position the coupling key in the keyway provided in the motor shaft.
4. Align the keyway in the shaft coupling with the key in the motor shaft and slide the pump shaft coupling onto the motor shaft. (Do not tighten set screws in the coupling at this time.)

5. Cast iron models, Rotate the pump housing counter clockwise (left hand threads) onto the suction inlet until the pump housing contacts the shoulder on the suction inlet. Tighten with a strap wrench. Take care not to pinch the o-ring.

Screw the discharge counter clockwise (left hand threads) into the pump housing until the discharge bottoms out against the pump housing. Take care not to pinch the o-ring.

Stainless steel models - Rotate the discharge/pump housing counter clockwise (left hand threads) onto the suction inlet until the discharge/pump housing bot-

tom out against the suction inlet. Tighten with a wrench. Take care not to pinch the o-ring.

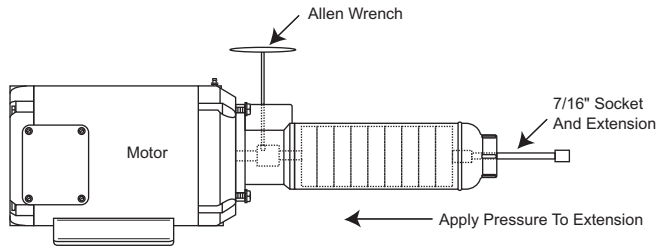

6. Seal the set screws in the coupling with pipe sealant to prevent pumping liquid from contacting the motor shaft. Before tightening the set screws in the coupling, push on the cap screw located at the end of the pump inside the discharge housing with a 7/16" socket and extension. This will cause the motor shaft to "Bottom Out" inside the pump shaft coupling. While pushing on the cap screw, tighten the set screws in the shaft coupling.

Mechanical Seal Replacement

1. Follow instructions under "Removal of Rotating Assembly."
2. Remove the rotating element of the seal (carbon ring, seal, and spring) by grasping the element and pulling/twisting it off the motor shaft.
3. Use a screwdriver to remove the ceramic seat and rubber seat ring from the seal cavity as shown. Be careful not to damage sealing surfaces on the seal cavity.

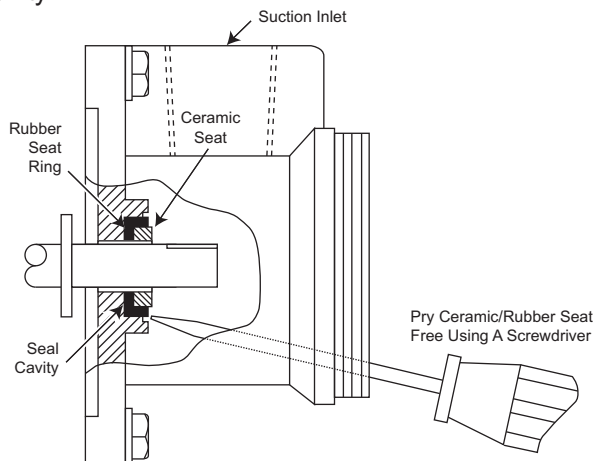

Mechanical Seal Installation

1. Clean seal cavity, removing all rust and scale.

2. A) Lubricate the rubber seat ring with mineral oil. With a 3/4" socket or piece of 3/4" PVC pipe, press ceramic seat firmly and squarely into the seal cavity. Be sure the seal face is not damaged during assembly (cracked, scratched, or chipped) or the seal will leak.

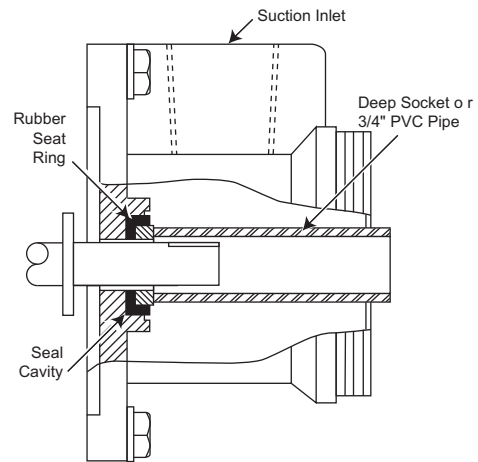

B) Clean polished surface of ceramic seat with a soft cloth or tissue to remove all dust and grit.

C) Inspect motor shaft to make sure it is clean.

D) To prevent slip-stick lightly lubricate both the ceramic and carbon seal face with mineral oil. Do not let oil get on to the motor shaft or the rubber driving ring of the mechanical seal.

E) For ease of assembly lubricate the driving ring on the mechanical seal with water. By hand carefully press the rotating seal assembly onto the motor shaft. The carbon seal face must contact the ceramic seal face. The driving ring must seal against the motor shaft.

F) Place a 28B116-V gasket over the motor shaft and against the rotating element of the mechanical seal. Slide the 99X151-6 key in the keyway in the motor shaft.

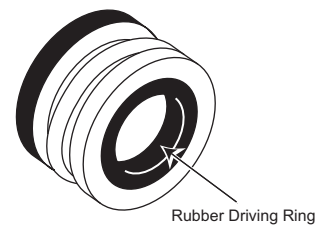

3. To reassemble the rotating assembly refer to Installation of Rotating Assembly (RA)

Removal of Motor

Warning: Always disconnect the electrical supply prior to servicing the pump.

1. Refer to "Removal of Rotating Assembly" (RA)
2. Refer to "Mechanical Seal Replacement" instruction 2.
3. Remove the (4) 3/8" bolts that attach the suction inlet to the motor.
4. Pull the suction inlet away from the motor.

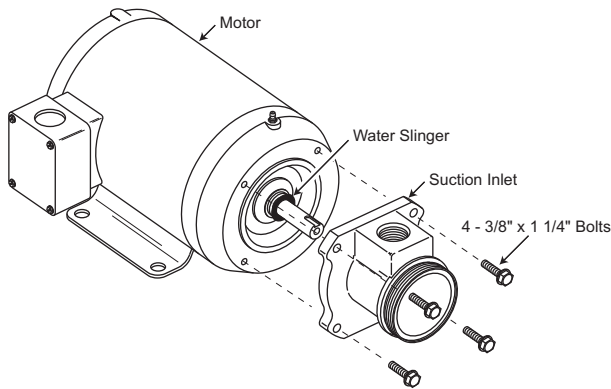

Installation of Motor

1. Measure the length of the motor shaft from the mounting surface of the motor to the shoulder of the motor shaft that butts up against the pump shaft coupling. This dimension should be $2.560 \pm .010$.

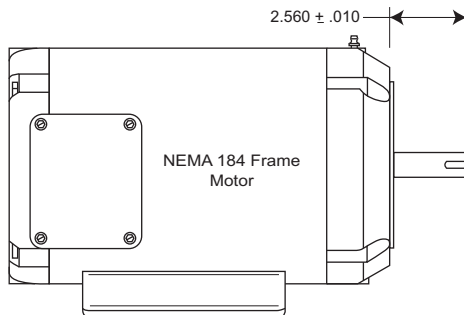

2. Inspect shaft to make sure it is clean.
3. Slide the water slinger over the shaft, as far back as possible.
4. Fasten, the suction inlet to the motor with (4) 3/8" x 1 1/4" bolts.

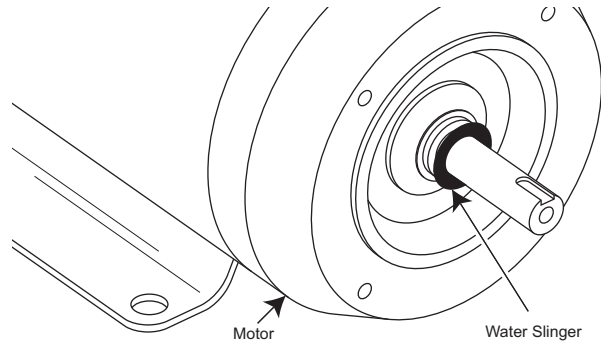

5. Refer to "Mechanical Seal Installation". and "Installation Of Rotating Assembly" instructions 1-6.

Final Inspection

1. After reassembly, rotate the pump shaft. It should be free enough to be turned by hand. To do this, insert a 7/16" socket into the discharge and rotate the hex head cap screw clockwise.
2. If you can turn the shaft with minimum effort, the booster pump is operable. If you cannot rotate the pump shaft, check the following for improper installation.

A) The motor shaft must be bottomed out inside the pump shaft coupling.

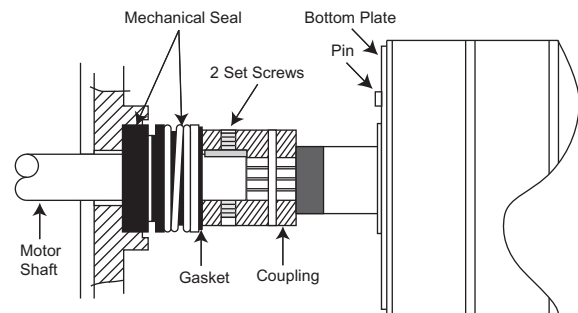

Rotating Assembly (RA)

B) The bottom plate must be installed properly. See Installation of Rotating Assembly, instruction 2.

C) The pump housing must be firmly tightened against the shoulder of the suction inlet and discharge.



There when you need us most

8417 New Hampshire Ave. | St. Louis, MO 63123

Phone: (314) 631-9200

Fax: (314) 631-3738

E-mail: comments@webtrol.com