

Installation & Operating Manual

2514TB-M
9/06 Edition

WEBTROL
Quality Pumps



IN-LINE Series

5 - 35 GPM BOOSTER

**Congratulations On Your Choice
In Purchasing This Webtrol Pump**

Its Quality is unsurpassed in material and workmanship and has been factory tested.
If properly installed, it will give many years of trouble free service.

Table Of Contents

| | | | |
|--|----------|---|-----------|
| Introduction | 2 | Start-Up Procedures | 7 |
| Damaged material or shortages | | Valves | |
| Handling | | Priming | |
| Warnings | 2 | Shaft rotation | |
| In-Line Booster Exploded View | 3 | Suction flow | |
| Pre-Installation | 4 | Final inspection | |
| Installation | 5 | Maintenance And Repair | |
| Location | | Motor removal | 8 |
| Mounting | | Motor installation | 8 |
| Piping | | Removal of rotating assembly | 8 |
| Pre Start-Up | 5 | Installation of rotating assembly | 9 |
| Typical installations, figures 1 & 2 | | Parts illustration | 9 |
| Electrical Connections | 6 | System Trouble Shooting | 11 |
| | | Spare Parts | 12 |

Introduction

This manual was prepared to assist the installer and/or operator in understanding the proper method of installing, operating and maintaining the In-Line Booster Pump. Prior to starting the pump, thoroughly understand the correct installation and start-up procedures. If this is done, you will have years of trouble free service.

DAMAGED MATERIAL OR SHORTAGES

When the pump is received, examine the shipment to determine if it has been damaged or if any parts are missing. If so, note the damage or shortage on the bill of lading and the freight bill. Make any claims to the transportation company immediately. Retain the packaging materials until the claim is resolved.

The pump should remain in the shipping carton until it is ready to be installed.

HANDLING

When handling the pump, support both the motor and pump housing. This can be done by wrapping a sling around the pump and motor. To avoid damage, handle the pump and motor with care.

WARNING

Rules For Safe Installation And Operation

1. Read these rules and instructions carefully. Failure to follow them could cause serious bodily injury and/or property damage.
2. Check your local codes before installing.
3. For maximum safety, this product should be connected to a grounded circuit, equipped with a ground fault interrupter device.
4. Before installing this product, have the electrical circuit checked by an electrician to make sure it is properly grounded.
5. Before installing or servicing your pump, BE CERTAIN pump power source is disconnected.
6. Make sure the pump model, HP, voltage, phase and frequency, 50 or 60 Hz match the installation requirements.
7. The pump is designed for potable water only. Do not pump chemicals or corrosive liquids with the pump unless they are compatible with the pump component materials: (Consult Webtrol for verification at 314-631-9200).

In-Line Booster Cut-A-Way View

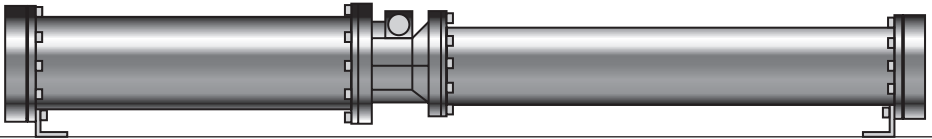
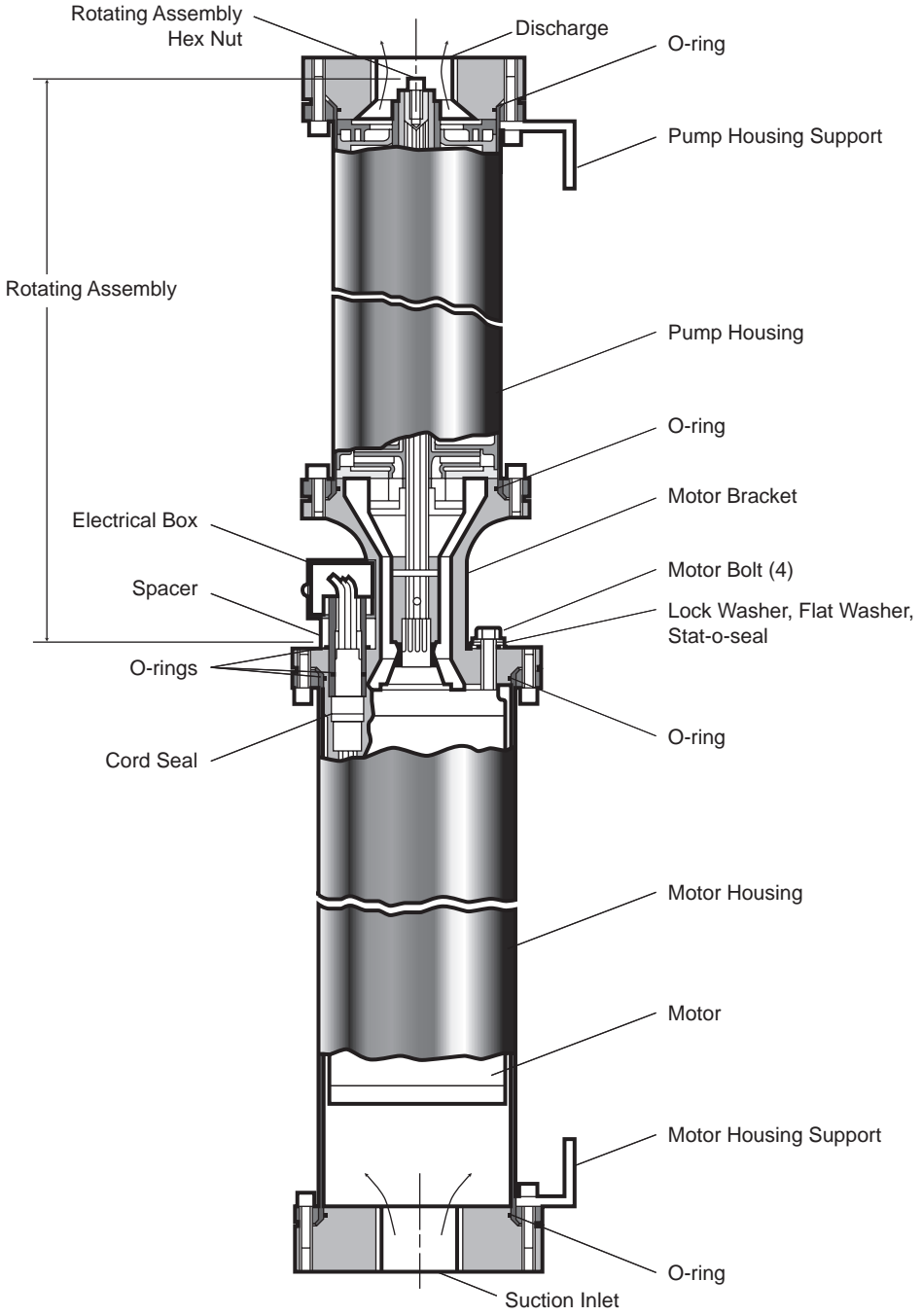

Pre-Installation

Examine the components carefully to ensure that no damage has occurred to the liquid end, motor, cable, control box or magnetic starter during shipment. Report damage immediately to the shipping carrier or to your dealer. The Webtrol In-Line Booster Pump should remain in the shipping carton until it is ready to be installed. Do not drop or mishandle the pump prior to installation.

The minimum inlet pressure is 2 PSI because allowable water temperature is based upon having at least atmospheric pressure on the water surrounding the motor.

Maximum water temperature should not exceed 30 degrees celsius (86 degrees F). If warmer water is pumped, the motor must be derated.

The 316SS motor housing is designed to operate at up to maximum service factor Hp in water up to 86 degrees F. A flow of 0.25 ft./sec (3 GPM) is required for proper cooling. This minimum flow rate will prevent premature motor failure.

To prevent upthrust, the maximum flow rate for the 5 GPM Series is 8 GPM, 10 GPM Series is 15 GPM, 15 GPM Series is 19 GPM, 20 GPM Series is 28 GPM and the 35 GPM Series is 38 GPM.

Pump performance is base upon pumping clear and cold water that is free of air or gases.

The pump should be sized properly for flow and Total Dynamic Head (TDH).

The electrical wiring must be done by qualified personnel. All wiring must meet National Electrical Code or Canadian Electrical Code as well as local code requirements and regulations.

Control boxes and panels should never be mounted in high temperature locations as this will cause a reduction in capacitor life and unnecessary tripping of the overload protectors. Check that the electrical installation and controls meet all safety regulations and match the motor requirements, including fuse or circuit breaker size and over load protection.

Connect all metal plumbing and electrical enclosures to the power supply ground.

Note: For three phase motors, ambient compensated overload protection to be sized for the service factory current of the motor and not full load current.

Important: Use a regulating valve in the discharge line to prevent the pump from going into upthrust.

Water should never be forced through the pump (more than momentarily in either direction) without the pump running as failure due to up-thrust or bearing wear may occur.

Pressure relieving valves should be used to prevent running the pump at shut-off pressure. This will prevent the water from heating up and damaging the motor and thermoplastic pump components.

Horizontal operation is acceptable so long as the pump transmits thrust to the motor. For vertical operation, the motor/inlet end must be down to prevent undue wear to the motor up-thrust bearing.

The pump must never run dry or both the motor and rotating assembly will be damaged and require replacement.

The entire pump must be supported sufficiently to prevent binding or over-stressing the motor, pump and piping.

Voltage must be within $\pm 10\%$ of the motor nameplate voltage.

Never run the pump with a closed discharge. To do so will cause the water to heat up and damage the pump components and motor.

Installation

LOCATION

Locate the pump as close to the liquid source as possible, so that a direct suction pipe may be used. Place the unit so that it is readily accessible for service and maintenance. Avoid air pockets in the suction piping that will make priming difficult. (See Figures 1 & 2, Pages 5 & 6)

Note! Provide adequate space for the use of a tow - motor or hoist if required. Also, never position the pump in such a way that will allow a person to use it as a step.

MOUNTING

The pump can be mounted in a horizontal or vertical position. To avoid excessive wear on the upthrust bearing in the vertical position, the motor/suction inlet must be down. Bolt the pump to a secure and dry base. This will prevent noise, vibration, or creeping. A mounting angle with two holes for two 3/8-16NC bolts are provided at each end of the pump. U-bolts or clamps should not be used because they could damage the pump/motor housing.

PIPING

To minimize friction losses, the 1 1/2" suction line should be short with as few elbows as possible. The piping should be galvanized, rigid plastic or other suitable pipe that will not collapse or burst when exposed to suction or discharge pressure. Never use quick closing valves or throttle the pump on the inlet side. Install a pressure gage next to the inlet connection to the pump. The gage reading should not be less than 2 PSI while the pump is running. Whenever possible, place a pipe union close to the pump inlet and discharge connection as you can. This will make removal of the pump easier should it ever need to be repaired.

Pre Start-Up

Prior to installing the piping and wiring the motor, rotate the pump shaft. To do this, insert a 7/16" nut driver into the discharge and rotate the hex head cap screw clockwise. Clockwise rotation will avoid releasing the compression on the impeller, which can cause the pump to fail. The pump shaft must rotate freely. If the pump shaft cannot be rotated, do not proceed. Contact your Webtrol representative or call the Webtrol factory at 314-631-9200 and ask for assistance.

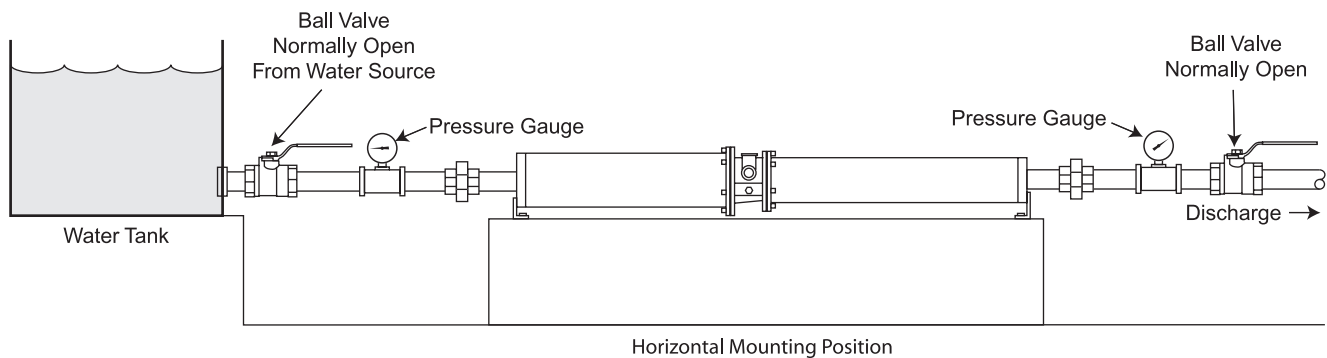

Figure 1 - This pump installation is designed to boost water pressure obtained from a water tank, which provides a gravity flow, flooded suction.

Important: Use a regulating valve in the discharge line to prevent the pump from going into upthrust.

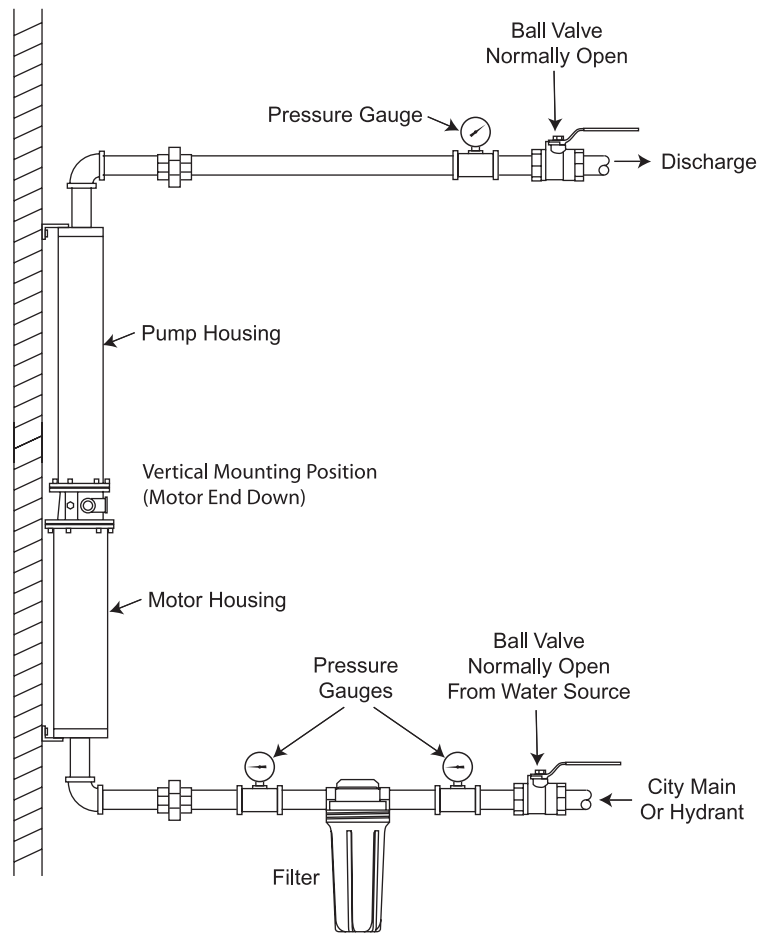

Figure 2 - Whenever dirt, sand or debris is present in the water supply, install a filter or strainer to prevent clogging or damaging the pump. A clogged strainer will cause a pressure loss and the pump may cavitate. A low pressure shut-off switch should be installed between the strainer and pump.

Electrical Connections

Before wiring the pump to the power source, verify that the motor voltage, phase and frequency match the power supply. The supply voltage must be within plus or minus 10% of the nameplate voltage. Note! Incorrect voltage can cause fire or seriously damage the motor and voids the warranty. On 3 phase installations, use a magnetic starter and three quick trip overload heaters. Failure to use quick trip heaters in all three lines will not provide adequate motor protection and the warranty will be void. Install the ground wire and maintain this pump in compliance with the National Electrical Code (NEC) or the Canadian Electrical Code (CEC) and with all local codes and ordinances that apply. Consult your local building inspector for local code information.

See tables 1 & 2 on pages 7 & 8 for motor specifications.

Start-Up Procedures

VALVES - The valve installed in the suction line should be fully opened and the discharge valve should be partially open. This will allow the pump to rapidly build pressure.

Notice: Never operate the pump with the discharge valve completely closed. The pump can destroy itself if run at shutoff pressure. Never start a pump with the discharge completely open. This can cause the pump to up thrust on the impeller-shaft assembly, which can cause premature wear and failure.

PRIMING - The pump will automatically fill with water when the pump is connected to a city main, hydrant or water tank. To relieve the trapped air inside the pump, allow the water supply to run a minimum of 1 minute before starting the pump. Then, turn the motor on and off several times to free the air trapped inside the pump. Repeat this priming sequence several times to be sure that all the air has been removed from the pump.

SHAFT ROTATION - To determine if the 3-phase motor is rotating in the correct direction (clockwise) observe the discharge gage pressure. If the motor is wired uncorrectly, the pressure will be less than half of what it should be. To correct interchange any two motor leads.

SUCTION FLOW - To insure that the pump is adequately lubricated with water, the pressure gauge installed on the suction line should read at least 2 PSI during operation. If necessary a switch can be used to shut the pump off on low inlet pressure, 0 PSI.

FINAL INSPECTION - During the first few hours of operation, inspect the pump, piping and any auxiliary equipment used in conjunction with the unit. Check for leaks, excessive vibration, and unusual noises.

If a problem arises, consult your Webtrol Representative or call the Webtrol Factory for assistance. (314) 631-9200.

Table 1

| Single Phase Motor Specifications (60HZ) 3450 RPM | | | | | | | | | | | | | | | | |
|--|--------------------------|-------|------|-------|----|------|-------------------------|-------|-------------------------|------------------|---|-------------------|----------|--|------------------------------|-----------------|
| Type | Motor Model | HP | KW | Volts | HZ | S.F. | Rated Input (Full Load) | | Maximum (S.F. Load) | | Winding (1) (Resistance/ Ohm) Res. M=Main | Locked Rotor Amps | KVA Code | Circuit Breaker Or Fuse Amps (Maximum Per NEC) | | |
| | | | | | | | (2) Amps | Watts | (2) Amps | Watts S=Start | | | | Standard Fuse | Dual Element Time Delay Fuse | Circuit Breaker |
| 4-Inch 3-Wire | 214508 w/ 1 1/2 CB | 1 | 0.75 | 230 | 60 | 1.4 | Y6.6 B6.6 R1.3 | 1130 | Y8.0 B7.9 R1.3 | 1490 | M2.2-2.7 S9.9-12.1 | 43 | L | 30 | 20 | 25 |
| | 224300 | 1 1/2 | 1.1 | 230 | 60 | 1.3 | T10.0 B9.9 R1.3 | 1700 | Y11.5 B11.0 R1.3 | 2150 | M1.7-2.2 S8.0-9.7 | 52 | J | 35 | 20 | 30 |
| | 224301 | 2 | 1.5 | 230 | 60 | 1.25 | Y10.0 B9.3 R2.6 | 2100 | Y13.2 B11.9 R2.6 | 2650 | M1.8-2.3 S5.8-7.2 | 51 | G | 30 | 20 | 25 |
| | 224302 | 3 | 2.2 | 230 | 60 | 1.15 | Y14.0 B11.2 R6.1 | 3020 | Y17.0 B12.6 R6.0 | 3430 | M1.0-1.5 S4.0-4.9 | 83.5 | H | 45 | 30 | 40 |
| | 224303 | 5 | 3.7 | 230 | 60 | 1.15 | Y23.0 B15.9 R10.8 | 5250 | Y27.5 B19.1 R10.8 | 5960 | M.68-1.0 S1.8-2.2 | 121 | F | 80 | 45 | 60 |

(1) Main winding - yellow to black Start winding - yellow to red

(2) Y=yellow lead, line amps B=black lead, main winding amps R=red lead, Start or auxiliary winding amps

Table 2

| 4 Inch Three Phase Motor Specifications (60HZ) 3450 RPM | | | | | | | | | | | | | | | |
|--|-------|------|-------|----|------|-------------------------|-------|---------------------|-------|-------------------------------|-------------------|----------|--|------------------------------|-----------------|
| Motor Model | HP | KW | Volts | HZ | S.F. | Rated Input (Full Load) | | Maximum (S.F. Load) | | Line to Line (Resistance Ohm) | Locked Rotor Amps | KVA Code | Circuit Breaker Or Fuse Amps (Maximum Per NEC) | | |
| | | | | | | Amps | Watts | Amps | Watts | | | | Standard Fuse | Dual Element Time Delay Fuse | Circuit Breaker |
| 234503 | 1 | 0.75 | 200 | 60 | 1.4 | 4.5 | 1070 | 5.4 | 1440 | 3.8-4.5 | 30.9 | M | 15 | 10 | 15 |
| 234513 | 1 | 0.75 | 230 | 60 | 1.4 | 3.9 | 1070 | 4.7 | 1440 | 4.9-5.6 | 26.9 | M | 15 | 8 | 10 |
| 234543 | 1 | 0.75 | 380 | 60 | 1.4 | 2.3 | 1070 | 2.8 | 1440 | 12.2-14.9 | 16.3 | M | 8 | 5 | 8 |
| 234523 | 1 | 0.75 | 460 | 60 | 1.4 | 2 | 1070 | 2.4 | 1440 | 19.9-23.0 | 13.5 | M | 6 | 4 | 5 |
| 234504 | 1 1/2 | 1.1 | 200 | 60 | 1.3 | 5.8 | 1460 | 6.8 | 1890 | 2.5-3.0 | 38.2 | K | 20 | 10 | 15 |
| 234514 | 1 1/2 | 1.1 | 230 | 60 | 1.3 | 5 | 1460 | 5.9 | 1890 | 3.2-4.0 | 33.2 | K | 15 | 10 | 15 |
| 234544 | 1 1/2 | 1.1 | 380 | 60 | 1.3 | 3 | 1460 | 3.6 | 1890 | 8.5-10.4 | 20.1 | K | 10 | 6 | 8 |
| 234524 | 1 1/2 | 1.1 | 460 | 60 | 1.3 | 2.5 | 1460 | 3.1 | 1890 | 13.0-16.0 | 16.6 | K | 8 | 5 | 8 |
| 234534 | 1 1/2 | 1.1 | 575 | 60 | 1.3 | 2 | 1460 | 2.4 | 1890 | 20.3-25.0 | 13.3 | K | 6 | 4 | 5 |
| 234305 | 2 | 1.5 | 200 | 60 | 1.25 | 7.7 | 2150 | 9.3 | 2700 | 1.8-2.4 | 53.6 | L | 25 | 15 | 20 |
| 234315 | 2 | 1.5 | 230 | 60 | 1.25 | 6.7 | 2150 | 8.1 | 2700 | 2.3-3.0 | 46.6 | L | 25 | 15 | 20 |
| 234345 | 2 | 1.5 | 380 | 60 | 1.25 | 4.1 | 2150 | 4.9 | 2700 | 6.6-8.2 | 28.2 | L | 15 | 8 | 15 |
| 234325 | 2 | 1.5 | 460 | 60 | 1.25 | 3.4 | 2150 | 4.1 | 2700 | 9.2-12.0 | 23.3 | L | 15 | 8 | 10 |
| 234335 | 2 | 1.5 | 575 | 60 | 1.25 | 2.7 | 2150 | 3.2 | 2700 | 14.6-18.7 | 18.6 | L | 10 | 5 | 8 |
| 234306 | 3 | 2.2 | 200 | 60 | 1.15 | 10.9 | 2980 | 12.5 | 3420 | 1.3-1.7 | 71.2 | K | 35 | 20 | 30 |
| 234316 | 3 | 2.2 | 230 | 60 | 1.15 | 9.5 | 2980 | 10.9 | 3420 | 1.8-2.2 | 61.9 | K | 30 | 20 | 25 |
| 234346 | 3 | 2.2 | 380 | 60 | 1.15 | 5.8 | 2980 | 6.6 | 3420 | 4.7-6.0 | 37.5 | K | 20 | 15 | 15 |
| 234326 | 3 | 2.2 | 460 | 60 | 1.15 | 4.8 | 2980 | 5.5 | 3420 | 7.2-8.8 | 31 | K | 15 | 10 | 15 |
| 234336 | 3 | 2.2 | 575 | 60 | 1.15 | 3.8 | 2980 | 4.4 | 3420 | 11.4-13.9 | 24.8 | K | 15 | 8 | 10 |
| 234307 | 5 | 3.7 | 200 | 60 | 1.15 | 18.3 | 5050 | 20.5 | 5810 | .74-.91 | 122 | K | 60 | 35 | 50 |
| 234317 | 5 | 3.7 | 230 | 60 | 1.15 | 15.9 | 5050 | 17.8 | 5810 | 1.0-1.2 | 106 | K | 50 | 30 | 40 |
| 234347 | 5 | 3.7 | 380 | 60 | 1.15 | 9.6 | 5050 | 10.8 | 5810 | 2.9-3.6 | 64.4 | K | 30 | 20 | 25 |
| 234327 | 5 | 3.7 | 460 | 60 | 1.15 | 8 | 5050 | 8.9 | 5810 | 4.0-4.9 | 53.2 | K | 25 | 15 | 20 |
| 234337 | 5 | 3.7 | 575 | 60 | 1.15 | 6.4 | 5050 | 7.1 | 5810 | 6.4-7.8 | 42.6 | K | 20 | 15 | 20 |

Maintenance And Repair

Read this section thoroughly before making any repairs.

Caution: Never attempt any repair work unless electrical supply has been disconnected.

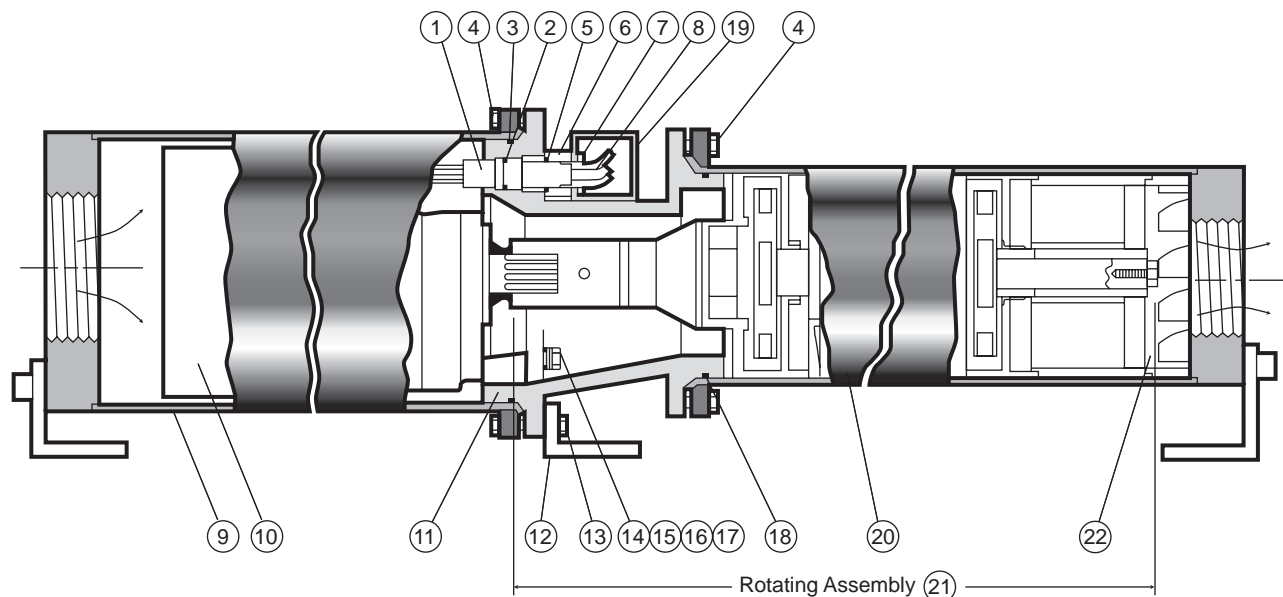

Motor Removal - Remove the cover of conduit box **19** and unscrew nut **7** using a 3/4" open end wrench. Lift off spacer **6**, "O"-ring **5** and conduit box **19**. Unscrew (6) hex head bolts **4** securing the motor mousing assembly **9**. Slide the motor housing off the motor **10**. Unscrew (4) hex head bolts **14** holding the motor **10** to the motor bracket **11** and remove them along with assorted washers **15, 16, 17**. Remove motor **10**. Unscrew cord seal **1** from the motor using using a 3/4" open end wrench. Pull the motor lead **8** out of the motor **10**.

Motor Installation - Remove o-ring **2** from cord seal **1** and install a new o-ring lubricated with silicone grease. Lubricate the rubber plug of a new motor lead **8** and push it into the motor. Lubricate the larger threaded end of cord seal **1** with silicone grease and screw it into the motor with a torque of 60 to 70 ft. lb. Place the motor bracket **11** onto the motor with the cord seal **1** passing through the hole in the motor bracket **11**. Before bolting the motor to the motor bracket, the three washers must be under the head of each screw. First slide a lockwasher **16** over the bolt. Then place a flat washer **15** against the lockwasher. Now lubricate the stat-o-seal **17** with Mobil FM102 Food Grade Machinery Grease NLG1 #2 or equivalent. Secure the motor to the bracket with (4) 1/2-20NF hex head screws **14**. Remove the o-ring **3** from the motor bracket **11** and replace it with a new one lubricated with silicone grease. Push the motor housing assembly **9** over the motor bracket **11**. Tighten (6) hex head bolts **4** into the motor bracket making sure the support on the end of the motor housing aligns with the discharge end. Place a lubricated o-ring **5** over the cord seal **1** followed by the spacer **6** with the chamfered end against the o-ring. Place the conduit box **19** against the spacer and tighten nut **7** against the conduit box **19**. After insuring that electrical power has been disconnected, make wiring connections with wire nuts and reconnect ground wire to box. Replace conduit box cover.

Removal Of Rotating Assembly - Remove the (6) 3/8"-16NC hex head bolts **4** with lock washers holding the pump housing assembly **20** to the motor bracket **11**. Pull off the pump housing assembly **20** along with the rotat- ing assembly **21**. Pull the rotating assembly out of the pump housing assembly.

Installation Of Rotating Assembly - Before installing the new rotating assembly, the motor shaft height must be measured. Referring to *Figure 3*, if the dimension is greater than 3.378", the motor thrust bearing has worn excessively and the motor needs to be replaced. If this is ignored, the rotating assembly could be destroyed on first start-up because the impellers will rub against the diffusers causing them to fuse together. Remove the o- ring **18** from the motor bracket **11** and replace it with a new one lubricated with silicone grease. Place the 1 3/16" wide spacer ring **22** removed from the old rotating assembly on the diffusers of the new rotating assembly **21**.

Figure 3

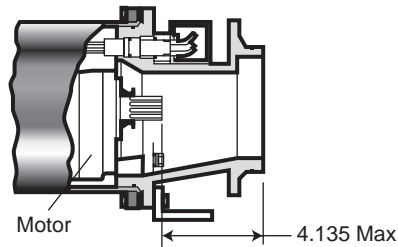

One side of the ring is flat, while the other side has a step or shoulder which fits into the diffuser. Slide the rotating assembly **21** into the pump housing assembly **20**. Slip the pump housing **20** with the rotating assembly over the motor bracket **11** making sure the shaft coupling spline engages the motor shaft spline. Insert the (6) 3/8-16NC hex head bolts **4** with lock washers through the pump housing flange and into motor bracket. Align the support foot and tighten each screw one turn in a diagonal pattern until each bolt is tight and the tube is completely seated against the motor bracket **11**.

Check For Free-Turning Pump - Prior to starting the pump, check to see if the pump shaft will turn by hand. To do this, insert a 7/16" nut driver over the hex head screw located inside the discharge end of the pump. If you can turn the shaft clockwise with minimal effort, the pump is operable. If the pump shaft cannot be turned, the pump housing may not be tight against the motor bracket **11**, or the plastic ring **22** was not installed correctly.

System Trouble Shooting

Motor Will Not Start

| Possible Cause Of Trouble | Corrective Action |
|--|---|
| No power or line voltage is not within + of rated motor voltage. | |
| Fuses blown or circuit breaker tripped. | Check for loose, dirty or corroded connections in fuse receptacle. Check for tripped circuit breaker. |
| Defective pressure, flow or temperature switches. | Check voltage at contact points. Partially burned contact points can cause low voltage. |
| Control box malfunction (single phase). | Trouble shooting procedure is inside control box. |
| Bound pump due to . . . | A. Improper rotating assembly replacement or repairs. B. Pump was allowed to run dry and seized up. C. Pump was run with a closed discharge valve and excessive heat melted the rotating assembly. D. Rotating assembly attacked by acids, alkalies, cleaning solutions etc. E. Motor thrust bearing has worn enough to cause impeller to drop and rub diffusers. Note: Locked rotor amperage will be from 3 to 5 times higher than service factor amperage. |
| Grounded motor. | Disconnect power and clip one ohmmeter lead to each motor lead and touch the motor casing with the other lead. A zero reading for any motor lead indicates the motor is grounded. |

Motor Starts, But Overloads Or Heaters Trip After A While

| Possible Cause Of Trouble | Corrective Action |
|---|---|
| Low inlet flow will cause motor to heat up. | Flow must be a minimum of 11 GPM. |
| High inlet fluid temperature will cause motor to heat up. | Inlet temperature must not be greater than 95 degrees F. |
| Three phase current unbalance exceeds 5%. | Roll leads. |
| Voltage is not within + 10% of rated motor voltage. | Check pressure switch contact points. |
| Control box malfunction (single phase). | Trouble shooting procedure is inside control box. |
| Grounded motor. | Disconnect power and use ohmmeter to check resistance between leads. Compare with data in table. If any Ohm value is less than normal, the motor is grounded. If any Ohm value is greater than normal the winding is open, or there is a poor connection. |
| Motor overloading because fluid viscosity or specific gravity is higher than that of water. | Check fluid. |
| Control box horsepower or voltage does not match motor. | Check rating. |

Low Flow

| Possible Cause Of Trouble | Corrective Action |
|---|---|
| Three phase motors can turn in the wrong direction if wired incorrectly and cause the flow to be less than half of what it should be. | To reverse rotation and cause flow and pressure to increase, reverse any two motor leads. |
| Foreign material (pipe dope, tape, etc.) can become lodged in the small impeller and diffuser passages, causing reduced flow. | Clean impeller and diffusers and Install an inlet screen. |
| Inadequate priming (removal of trapped air). | Re-prime pump. |
| System pressure large than what the pump was sized for. | Re-size pump. |
| Air leak in inlet piping. | Check fittings. |
| Closed discharge valve. | |
| Check valve sticking or installed backwards. | |
| Broken pump shaft. | Replace. |

Low Pressure

| Possible Cause Of Trouble | Corrective Action |
|---|---|
| Inadequate priming (removal of trapped air). | Re-prime pump. |
| Air leak in inlet piping. | Check fittings. |
| Clogged impeller, diffusers. | Clean impeller and diffusers and Install an inlet screen. |
| Three phase motors can turn in the wrong direction if wired incorrectly and cause the flow to be less than half of what it should be. | To reverse rotation and cause flow and pressure to increase, reverse any two motor leads. |
| Excessive flow. | Throttle back the discharge to decrease flow. |
| Broken pump shaft. | Replace. |

Recommended Spare Parts

| Item | Quantity | Description | Part Number |
|------|----------|-------------------|-------------|
| 2 | 1 | O-ring | 28B121-V |
| 18 | 1 | O-ring | 28B120-V |
| 3 | 1 | O-ring | 28B119-V |
| 5 | 1 | O-ring | 28B122-V |
| 17 | 4 | Sealing Washer | 28B1118-11 |
| 8 | 1 | Motor Lead | 86S100-M |
| 21 | 1 | Rotating Assembly | See Drawing |

Thank You For Purchasing A In-Line Series Pump

We at Webtrol are constantly working on new products to make your job easier, while making your systems more efficient, reliable and affordable.

Your opinion means a lot to us, so please let us know what you think about our In-Line Series Pump.

Weber Industries, Inc. / Manufacturers of Webtrol Products

8417 New Hampshire Ave. / St. Louis, MO 63123

Phone: (314) 631-9200 **Fax:** (314) 631-3738 **E-mail:** comments@webtrol.com