



*There when you need us most*

## **WS Series**

**6", 8", 10" Submersible Turbine Pumps**

# **Installation & Operating Manual**



**Congratulations on Your Choice in Purchasing this Webtrol Pump!**

Its Quality is unsurpassed in material and workmanship and has been factory tested.  
If properly installed, it will give many years of trouble free service.

## Table Of Contents

Subject	Page
Pre-Installation	2
Installation Instructions	3
Typical Installation	3
Starting Procedure	4
Submersible Motor Cooling	5
Electrical	6
Cable Selection, Single Phase Motors	6
Two Different Cable Sizes	6
6" Single Phase Motor Specifications	7
6" - 10" Three Phase Motor Specifications	7-9
Engine Driven Generators	9
Single & Three Phase Wiring Diagrams	10
Trouble Shooting	11
Owner Information	12

## Pre-Installation

Examine the components carefully to ensure that no damage has occurred to the liquid end, motor, cable, control box, or magnetic starter during shipment. Report damage immediately to the shipping carrier or to your dealer. The Webtrol WS Series Submersible Turbine Pump should remain in the shipping carton until it is ready to be installed. Do not drop or mishandle the pump prior to installation.

**Warning:** The motor is equipped with an electrical cable. It should NEVER be used to lift or carry the pump. Damage to the electrical cable can cause shock, burns or death!

The well driller should fully develop the well *before the pump is installed*. All sand and foreign matter should be removed. The pump and motor should be assembled in the vertical position to prevent stress on pump bracket and shafts.

Pump performance is based upon pumping clear and cold water that is free of air or gases.

Pumps should be sized properly, for flow and Total Dynamic Head (TDH).

To test the well water for purity, contact your local health department for the proper testing procedure.

Maximum water temperature should not exceed 86°F (30°C). The pump should be installed at least, 10 feet below the maximum drawdown level, but no less than 10 feet from the bottom of the well to allow for sediment build up.

The pump should be installed according to state water well codes governing the setting of pumps. All wiring must meet National Electrical Code or Canadian Electrical Code and local code requirements.

Verify that the pump model, HP, voltage, phase and frequency, 50 or 60 Hz, match the installation requirements.

Control boxes and panels should never be mounted in direct sunlight or high temperature locations as this will cause a reduction in capacitor life and unnecessary tripping of the overload protectors. Check that the electrical installation and controls meet all safety regulations and match the motor requirements, including fuse or circuit breaker size and overload protection. Connect all metal plumbing and electrical enclosures to the power supply ground. Do not ground to a gas supply line.

**Note:** For three phase motors, ambient compensated overload protection to be sized for the service factor current of the motor and not full load current.

## Installation

A typical installation diagram is shown in (Figure 1, page 4). All electrical work should be performed by a competent electrician in accordance with the National Electrical Code, or Canadian Electrical Code, as well as local codes and regulations.

Never run the pump unless it is completely submerged in water. If operated without water, the pump and motor could be severely damaged.

The riser pipe should be properly sized and selected based upon the flow rate and friction-loss factors.

**Notice:** Hold the pump with a wrench on the discharge head while installing the riser pipe or a check valve.

Protect all piping, fittings and water system components from freezing.

When lowering the pump into the well, do not scrape the electrical cable against the well casing. Secure the cable to the discharge pipe at 10' intervals with electrical tape.

To ensure that the pump and motor are free to rotate, rotate the pump shaft coupling by hand.

If the pump is capable of over pumping the well, a liquid level control is required.

An ohmmeter or megger should be used to measure the insulation resistance on the power cable every 20 feet as the pump is lowered. Note: A sudden drop indicates possible cable, splice or motor lead damage. (See Chart 1)

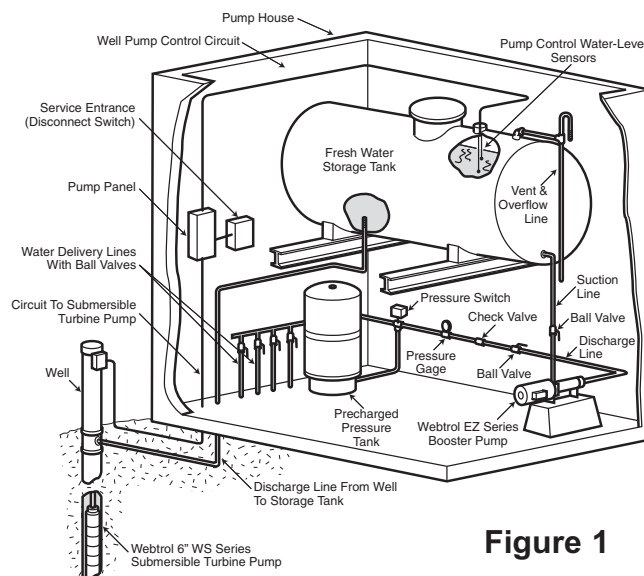
The values below are for copper conductors. If aluminum conductor drop cable is used, the resistance will be higher. To determine the actual resistance of the aluminum drop cable, divide the ohm readings from this chart by 0.61. This chart shows total resistance of cable from control to motor and back.

**Chart 1, DC Resistance in Ohms per 100 ft. of Wire (Two conductors) @ 50° F**

AWG or MCM Wire Size (Copper)		14	12	10	8	6	4	3	2		
Ohms		0.544	0.338	0.214	0.135	0.082	0.052	0.041	0.032		
1	1/0	2/0	3/0	4/0	250	300	350	400	500	600	700
0.26	0.21	0.017	0.013	0.010	0.0088	0.0073	0.0063	0.0056	0.0044	0.0037	0.0032

A check valve should always be installed in Submersible Turbine Pump installations. A line check valve should be installed within 20 feet of the pump, and below the drawdown level of the water supply. For installations deeper than 200 feet, check valves should be installed at no more than 200 foot intervals.

## Typical Installation for Submersible Turbine Pumps



**Figure 1**

## Starting Procedure

Make sure that the pump has been properly grounded prior to testing. Check all electrical, water line connections and parts before starting the pump.

**Notice:** Do not operate the pump with the discharge valve completely closed. The pump can destroy itself if run at shutoff pressure. Do not start the pump with the discharge completely open if the pump will operate at high flow - low head or if the pump is placed in an artesian well/open body of water. This can cause the pump to up thrust the impellers-shaft assembly, which can cause premature wear and failure.

To test the well water for clarity, attach a temporary horizontal length of pipe and gate valve to the riser pipe. (See Figure 2)

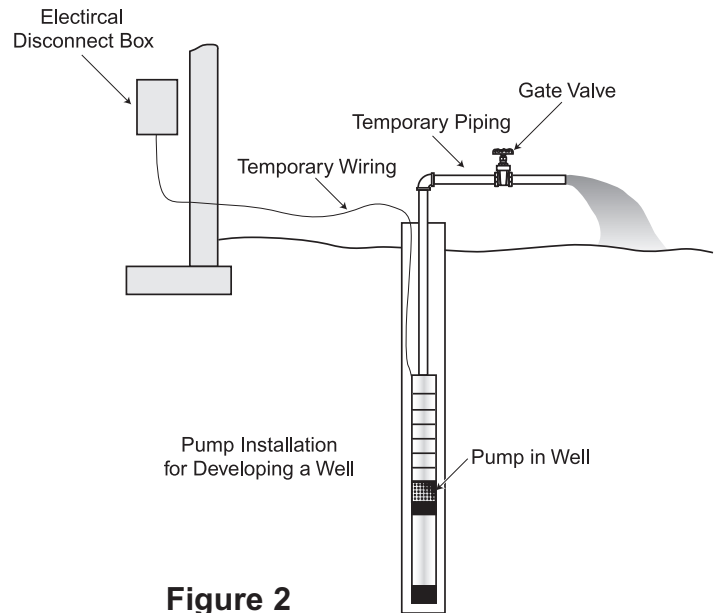
Make sure the controls are in the off position. Connect the motor leads and power supply to motor control box, fused disconnect switch or magnetic starter. See wiring diagrams. Do not start the pump!

Partially open the gate valve and start pump. "To make sure the 3 phase motor is running in the **right direction**, note the direction of **jerk** as the motor starts". If connections are properly made, the pump will jerk clockwise when looking into the pump discharge when started. If the jerk is counter - clockwise, the motor is running in the wrong direction. Interchange any two cable leads where they connect to the lead terminals in the magnetic starter. Restart the pump and let it operate until the water runs clear of sand, silt and other impurities.

When the water is completely clear at the initial gate valve setting, slowly open valve in small increments allowing the water to clear before progressing. The pump should not be stopped until the water runs clear.

Remove the gate valve for permanent installation.

Install sanitary well seal or pitless adapter unit, well unit, electrical conduit and surface piping according to local code requirements.



**Figure 2**

**Notice:** Check air pre-charge in tank before starting pump. Adjust pre-charge to 2 psi below pump cut-in setting. For example, a pre-charge tank used with a 30-50 switch should be pre-charged with air to 28 PSI (See Table 1). Adjust pre-charge by either adding or bleeding air through the valve located atop the tank. Check pre-charge annually and adjust as needed.

**Table 1**

Cut - On PSI	Cut - Off PSI	Pre-Charge Pressure PSI
20	40	18
30	50	28
40	60	38

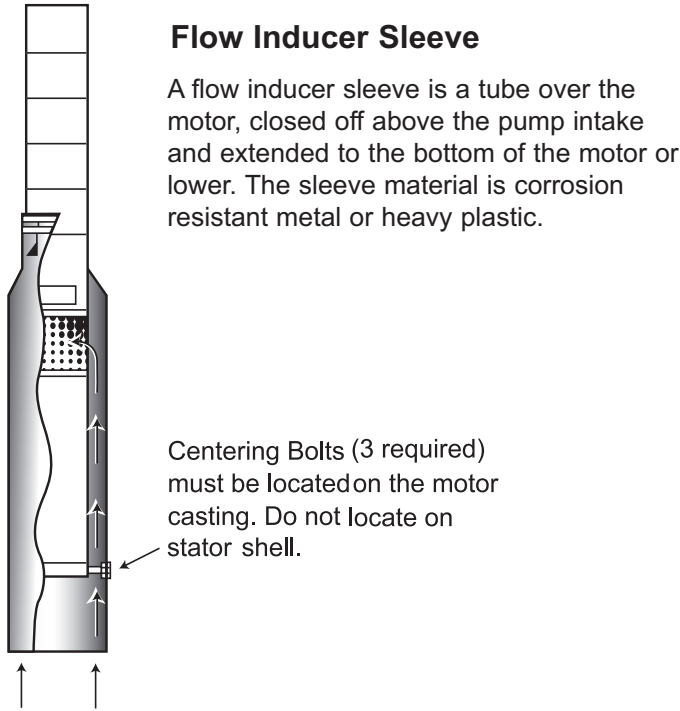
Pressure switches are set to maintain the tank pressure between 20/40 PSI, 30/50 PSI or 40/60 PSI. If another pressure setting is desired, consult the printed instruction card included with the pressure switch.

## Submersible Motor Cooling

The submersible motor requires a minimum flow of water past the motor to insure proper cooling. Table 2 below shows the minimum flow rates in GPM for various diameters.

If the flow rate is less than specified, a flow inducer sleeve or an alternate method of increasing water velocity past the motor must be used for proper cooling. (See Figure 3)

Several conditions requiring a flow sleeve are; the pump is in an open body of water, the well is top feeding and the well diameter is too large to meet Table 2 or Table 3 flow requirements.



**Figure 3**

**Table 2 Franklin Motors**

Casing or Sleeve I.D. Inches	6" Dia. Motor .50 ft/sec - GPM	8" Dia. Motor 50 ft/sec - GPM
6	9	-
7	25	-
8	45	-
10	90	10
12	140	55
14	200	110
16	280	245

**Table 3 Vansan Motors**

Casing or Sleeve I.D. Inches	6" Dia. Motor .65 ft/sec - GPM	8", 10" Dia. Motor 1.6 ft/sec - GPM
6	12	-
7	32	-
8	58.5	32
10	117	176
12	182	264
14	260	350
16	364	450

## Electrical

**Warning:** A faulty motor or wiring can be an electrical shock hazard if it or surrounding water is accessible to human contact. To prevent this from occurring, connect the motor frame to the power supply grounding terminal with a stranded copper conductor no smaller than the wires carrying current to the motor.

Electrical supply must match the motor voltage, phase and frequency found on the nameplate on the motor and control box. Motor electrical data can be found in Tables 4, 5, 6, 7, and 8. If voltage variations are larger than  $\pm 10\%$ , do not operate the pump.

On 3 phase installations, use a magnetic starter and quick trip overload heaters. Failure to use quick trip heaters in all three lines will not provide adequate motor protection and the warranty will be void.

**Caution:** Use of smaller than recommended cable voids warranty, can cause failure of the motor to start and operate properly, and may cause cable overheating!

The National Electrical Code requires that the control box or panel grounding terminal always be connected to supply ground. If the circuit has no grounding conductor and no metal conduit from the box to supply panel, use a wire at least as large as the line conductors and connect as required by the National Electrical Code, from the grounding terminal to the electrical supply ground.

**Warning:** Failure to ground the control frame can result in a serious or fatal electrical shock hazard if a circuit fault occurs.

## Cable Information

Sizes given are for copper wire. If aluminum wire is used, it must be two sizes larger and oxidation inhibitors must be used on the connections. Example: If the table calls for #4 copper wire, #2 aluminum wire would be required.

Maximum lengths shown maintain motor voltage at 95% of service entrance voltage, running at maximum nameplate amperes.

To comply to CSA, multiply the cable lengths shown by .6 for maximum feet. This will maintain motor voltage at 97% of service entrance voltage, running at maximum nameplate amperes.

The portion of the total cable length which is between the supply and single phase control box with a line contactor, should not exceed 25% of total maximum allowable to ensure reliable contactor operation. Single phase control boxes without line contactors may be connected at any point in the total cable length.

### Different Cable Sizes Can Be Used

Depending on the installation, any number of combinations may be used, as long as the total percentage length of the cables used does not exceed 100%. This is to insure that adequate voltage will be supplied to the motor.

Example: In a replacement installation, the well already has 100 feet of buried #8 cable between the service entrance and the well head. What size cable is required in the well with a 5 HP, 230 volt, 1 PH motor setting at 310 feet?

1. According to table 3, #8 cable is large enough for the 5 HP motor  $100 \div 280 = 35.7\%$ , since 280 feet is the total allowable cable length.
2. With 35.7% of the total allowable cable already used between the service entrance and the well head, only 64.3% is left for the well. Therefore, the 310 feet needed in the well can only utilize 64.3% of the total feet allowed in the table.
3. From the table, 64.3% of the 450 feet for #6 cable equals only 289 feet, so a larger size is needed. For #4, 64.3% of 710 feet = 456 feet. As a result, #4 can be used for the 310 feet in the well.

**Table 4**

Single Phase Motors															
Three Wire Cable, 60HZ (Service Entrance to Motor) Maximum Length in Feet															
Motor Rating			60°C Insulation - AWG Copper Wire Size												
Volts	HP	KW	14	12	10	8	6	4	3	2	1	0	00	000	0000
230	5	3.7	0	0	0	280	450	710	890	1110	1390	1740	2170	2680	
	7 1/2	5.5	0	0	0	0	310	490	610	750	930	1140	1410	1720	
	10	7.5	0	0	0	0	0	390	490	600	750	930	1160	1430	1760
	15	11	0	0	0	0	0	0	340	430	530	660	820	1020	1260

**Table 5**

Three Phase Motors																				
Three Phase, 60° C Cable, 60HZ (Service Entrance to Motor) Maximum Length in Feet																				
Motor Rating			60°C Insulation - AWG Copper Wire Size												MCM Copper Wire Size					
Volts	HP	KW	14	12	10	8	6	4	3	2	1	0	00	000	0000	250	300	350	400	500
230 3-Lead	5	3.7	0	230	370	590	920	1430	1790	2190	2690	3290	4030	4850	5870	6650	7560	8460	9220	
	7 1/2	5.5	0	0	260	420	650	1020	1270	1560	1920	2340	2870	3440	4160	4710	5340	5970	6500	7510
	10	7.5	0	0	0	310	490	760	950	1170	1440	1760	2160	2610	3160	3590	4100	4600	5020	5840
	15	11	0	0	0	0	330	520	650	800	980	1200	1470	1780	2150	2440	2780	3110	3400	3940
	20	15	0	0	0	0	0	400	500	610	760	930	1140	1380	1680	1910	2180	2450	2680	3120
	25	18.5	0	0	0	0	0	0	400	500	610	750	920	1120	1360	1540	1760	1980	2160	2520
30	22	0	0	0	0	0	0	0	0	510	620	760	930	1130	1280	1470	1650	1800	2110	
460 3-Lead	5	3.7	590	950	1500	2360	3700	5750												
	7 1/2	5.5	420	680	1070	1690	2640	4100	5100	6260	7680									
	10	7.5	310	500	790	1250	1960	3050	3800	4680	5750	7050								
	15	11	0	0	540	850	1340	2090	2600	3200	3930	4810	5900	7110						
	20	15	0	0	0	650	1030	1610	2000	2470	3040	3730	4580	5530						
	25	18.5	0	0	0	0	830	1300	1620	1990	2450	3010	3700	4470	5430					
	30	22	0	0	0	0	680	1070	1330	1640	2030	2490	3060	3700	4500	5130	5860			
	40	30	0	0	0	0	0	790	980	1210	1490	1830	2250	2710	3290	3730	4250			
	50	37	0	0	0	0	0	0	800	980	1210	1480	1810	2190	2650	3010	3420	3830	4180	4850
	60	45	0	0	0	0	0	0	0	0	1020	1250	1540	1850	2240	2540	2890	3240	3540	4100
	75	55	0	0	0	0	0	0	0	0	0	1030	1260	1520	1850	2100	2400	2700	2950	3440
	100	75	0	0	0	0	0	0	0	0	0	0	0	1130	1380	1560	1790	2010	2190	2550
125	93	0	0	0	0	0	0	0	0	0	0	0	0	0	1220	1390	1560	1700	1960	
150	110	0	0	0	0	0	0	0	0	0	0	0	0	0	0	0	1340	1460	1690	
175	130	0	0	0	0	0	0	0	0	0	0	0	0	0	0	0	0	1300	1510	
200	150	0	0	0	0	0	0	0	0	0	0	0	0	0	0	0	0	0	1310	

**Table 6**

Franklin Motors Single Phase Motor Specifications (60HZ) 3450 RPM																
Type	Motor Model	HP	KW	Volts	HZ	S.F.	Rated Input (Full Load)		Maximum (S.F. Load)		Winding (1) (Resistance /Ohms)	Locked Rotor Amps	KVA Code	Circuit Breakers Or Fuse Amps (Maximum Per NEC)		
							(2) Amps	Watts	(2) Amps	Watts				Res. M=Main S=Start	Standard Fuse	Dual Element Time Delay Fuse
6 Inch 3-Wire	226110	5	3.7	230	60	1.15	Y23.0 B14.3 R10.8	4910	Y27.5 B17.4 R10.5	5570	M.55-.68 S1.3-1.6	99	E	80	45	60
	226111	7 1/2	5.5	230	60	1.15	Y36.5 B34.4 R5.5	7300	Y42.1 B40.5 R5.4	8800	M.36-.50 S.88-1.1	165	F	125	70	100
	226112	10	7.5	230	60	1.15	Y44.0 B39.5 R9.3	9800	Y51.0 B47.5 R8.9	11300	M.27-.33 S.80-.99	204	E	150	80	125
	226113	15	11	230	60	1.15	Y62.0 B52.0 R17.5	13900	Y75.0 B62.5 R16.9	16200	M.17-.22 S.68-.93	303	E	200	125	175

(1) Main winding - black to yellow Start winding - red to yellow

(2) Y=yellow lead, line amps B=black lead, main winding amps R=red lead, start winding amps



**Table 7**

<b>Franklin Motors Three Phase Motor Specifications (60HZ) 3450 RPM</b>															
Motor Model	HP	KW	Volts	HZ	S.F.	Rated Input (Full Load)		Maximum (S.F. Load)		Line to Line (Resistance Ohms)	Locked Rotor Amps	KVA Code	Circuit Breakers Or Fuse Amps (Maximum Per NEC)		
						Amps	Watts	Amps	Watts				Standard Fuse	Dual Element Time Delay Fuse	Circuit Breaker
236650	5	3.7	200	60	1.15	17.5	4700	20.0	5400	.77-.93	99	H	60	35	45
236600	5	3.7	230	60	1.15	15	4700	17.6	5400	1.0-1.2	86	H	45	30	40
236660	5	3.7	380	60	1.15	9.1	4700	10.7	5400	2.6-3.2	52	H	30	20	25
236610	5	3.7	460	60	1.15	7.5	4700	8.8	5400	3.9-4.8	43	H	25	15	20
236620	5	3.7	575	60	1.15	6	4700	7.1	5400	6.3-7.7	34	H	20	15	15
236651	7 1/2	5.5	200	60	1.15	25.1	7000	28.3	8000	.43-.53	150	H	80	45	70
236601	7 1/2	5.5	230	60	1.15	21.8	7000	24.6	8000	.64-.78	130	H	70	40	60
236661	7 1/2	5.5	380	60	1.15	13.4	7000	15	8000	1.6-2.1	79	H	45	25	35
236611	7 1/2	5.5	460	60	1.15	10.9	7000	12.3	8000	2.4-2.9	65	H	35	20	30
236621	7 1/2	5.5	575	60	1.15	8.7	7000	9.8	8000	3.7-4.6	52	H	30	20	25
236652	10	7.5	200	60	1.15	32.7	9400	37	10800	.37-.45	198	H	100	60	90
236602	10	7.5	230	60	1.15	28.4	9400	32.2	10800	.47-.57	172	H	90	50	80
236662	10	7.5	380	60	1.15	17.6	9400	19.6	10800	1.2-1.5	104	H	60	35	45
236612	10	7.5	460	60	1.15	14.2	9400	16.1	10800	1.9-2.4	86	H	45	25	40
236622	10	7.5	575	60	1.15	11.4	9400	12.9	10800	3.0-3.7	69	H	35	20	30
236653	15	11	200	60	1.15	47.8	13700	54.4	15800	.24-.29	306	H	150	90	125
236603	15	11	230	60	1.15	41.6	13700	47.4	15800	.28-.35	266	H	150	80	110
236663	15	11	380	60	1.15	25.8	13700	28.9	15800	.77-.95	161	H	80	50	70
236613	15	11	460	60	1.15	20.8	13700	23.7	15800	1.1-1.4	133	H	70	40	60
236623	15	11	575	60	1.15	16.6	13700	19	15800	1.8-2.3	106	H	60	30	45
236654	20	15	200	60	1.15	61.9	18100	69.7	20900	.16-.20	416	J	200	110	175
236604	20	15	230	60	1.15	53.8	18100	60.6	20900	.22-.26	362	J	175	100	150
236664	20	15	380	60	1.15	33	18100	37.3	20900	.55-.68	219	J	100	60	90
236614	20	15	460	60	1.15	26.9	18100	30.3	20900	.8-1.0	181	J	90	50	70
236624	20	15	575	60	1.15	21.5	18100	24.2	20900	1.3-1.6	145	J	70	40	60
236655	25	18.5	200	60	1.15	77.1	22500	86.3	25700	.12-.15	552	J	250	150	200
236605	25	18.5	230	60	1.15	67	22500	75	25700	.15-.19	480	J	225	125	175
236665	25	18.5	380	60	1.15	41	22500	46	25700	.46-.56	291	J	125	70	110
236615	25	18.5	460	60	1.15	33.5	22500	37.5	25700	.63-.77	240	J	110	60	90
236625	25	18.5	575	60	1.15	26.8	22500	30	25700	1.0-1.3	192	J	90	50	70
236656	30	22	200	60	1.15	90.9	26900	104	31100	.09-.11	653	J	300	175	250
236606	30	22	230	60	1.15	79	26900	90.4	31100	.14-.17	568	J	250	150	225
236666	30	22	380	60	1.15	48.8	26900	55.4	31100	.35-.43	317	J	150	90	125
236616	30	22	460	60	1.15	39.5	26900	45.2	31100	.52-.64	284	J	125	70	110
236626	30	22	575	60	1.15	31.6	26900	36.2	31100	.78-.95	227	J	100	60	90
236667	40	30	380	60	1.15	66.5	35600	74.6	42400	.26-.33	481	J	200	125	175
236617	40	30	460	60	1.15	54.9	35600	61.6	42400	.34-.42	397	J	175	100	150
236627	40	30	575	60	1.15	42.8	35600	49.6	42400	.52-.64	318	H	150	80	110
236668	50	37	380	60	1.15	83.5	45100	95	52200	.21-.25	501	H	250	150	225
236618	50	37	460	60	1.15	67.7	45100	77	52200	.25-.32	414	H	225	125	175
236628	50	37	575	60	1.15	54.2	45100	61.6	52200	.40-.49	331	H	175	100	150
236669	60	45	380	60	1.15	98.7	53500	111	61700	.15-.18	627	H	300	175	250
236619	60	45	460	60	1.15	80.5	53500	91	61700	.22-.27	518	H	250	150	225
236629	60	45	575	60	1.15	64.4	53500	72.8	61700	.35-.39	414	H	200	125	175
239603	75	55	460	60	1.15	94	64000	107	73500	.10-.13	864	L	-	-	-
239613	75	55	575	60	1.15	76	64000	86	73500	.16-.21	691	L	-	-	-
239604	100	75	460	60	1.15	132	85000	147	97500	.07-.09	1211	L	-	-	-
239614	100	75	575	60	1.15	101	85000	114	97500	.11-.13	969	L	-	-	-
239105	125	93	460	60	1.15	167	109000	188	125000	.05-.07	1318	K	-	-	-
239115	125	93	575	60	1.15	134	109000	151	125000	.08-.11	1054	K	-	-	-
239106	150	110	460	60	1.15	194	128000	219	146000	.04-.05	1620	K	-	-	-
239116	150	110	575	60	1.15	164	128000	182	146000	.06-.08	1296	K	-	-	-
239107	175	130	460	60	1.15	219	150000	249	173000	.04-.05	1645	J	-	-	-
239117	175	130	575	60	1.15	175	150000	200	173000	.06-.08	1316	J	-	-	-
238108	200	150	460	60	1.15	246	169000	282	194000	.03-.05	1875	J	-	-	-
239118	200	150	575	60	1.15	197	169000	226	194000	.05-.07	1500	J	-	-	-



**Table 8**

Vansan Motors Three Phase Motor Specifications (60HZ) 3450 RPM													
Motor Model	Power		Thrust Load	Voltage	Speed	Full Load	Locked Rotor	Efficiency (% Load)			PF (% Load)		
	HP	kW						Lb.	V	RPM	A	A	50
3S 6"/5.5	5	3.7	4500	230/460	3350	18.8/8.4	88/44	69	70	70	65	74	85
3S 6"/7.5	7.5	5.5	4500	230/460	3360	22.6/11.3	118/59	71	72	72	65	74	85
3S 6"/10	10	7.5	4500	230/460	3380	28.4/14.2	146/73	77	78	78	65	74	85
3S 6"/15	15	11	4500	230/460	3400	37.6/19.8	202/101	80	81	81	67	76	87
3S 6"/20	20	15	4500	230/460	3440	54.6/27.3	282/141	79	80	80	66	75	86
3S 6"/25	25	18.5	4500	230/460	3450	69.0/34.5	356/178	79	80	80	64	73	84
3S 6"/30	30	22	4500	230/460	3460	80.2/40.1	414/207	80	81	81	65	74	85
3S 6"/40	40	30	6000	460	3480	53.4	272	81	82	82	66	75	86
3S 7"/50	50	37	10100	460	3480	61.4	311	84	85	85	79	86	89
3S 7"/60	60	45	10100	460	3470	74.7	379	84	85	85	77	85	89
3S 8"/75	75	55	10100	460	3450	90.2	458	85	85	84	83	87	91
3S 8"/100	100	75	10100	460	3450	123.1	625	85	85	84	82	86	91
3S 8"/125	125	93	12500	460	3430	152.8	770	85	85	84	82	86	90

**Generator Operation**

**Warning:** To prevent accidental electrocution, automatic or manual transfer switches must be used any time a generator is used as standby or back up on power lines. Contact power company for use and approval.

Whenever the submersible pump is going to be operated using an engine driven generator, the generator manufacturer should be consulted. (See Table 9)

There are two types of generators available, externally and internally regulated. Most are externally regulated. They use an external mounted voltage regulator that senses the output voltage. As the voltage dips at motor start up, the regulator increases the output voltage of the generator.

Internally regulated generators have an extra winding in the generator stator and are also called self excited. The extra winding senses the output current to automatically increase the output voltage.

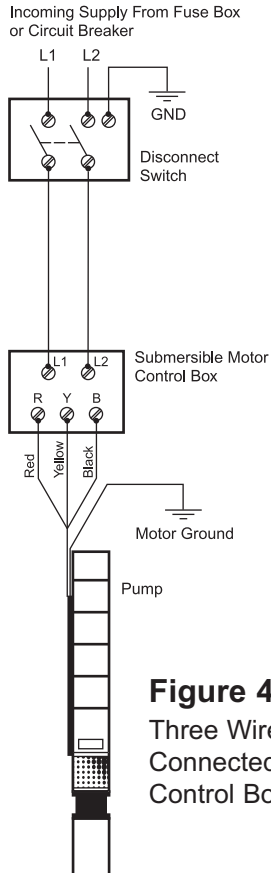
Always start the generator before the motor is started and turn the motor off before the generator is shut down.

**Note:** The Kingsbury thrust bearing in the motor may be damaged if the generator is allowed to coast down with the motor running. The same condition occurs when the generator runs out of fuel.

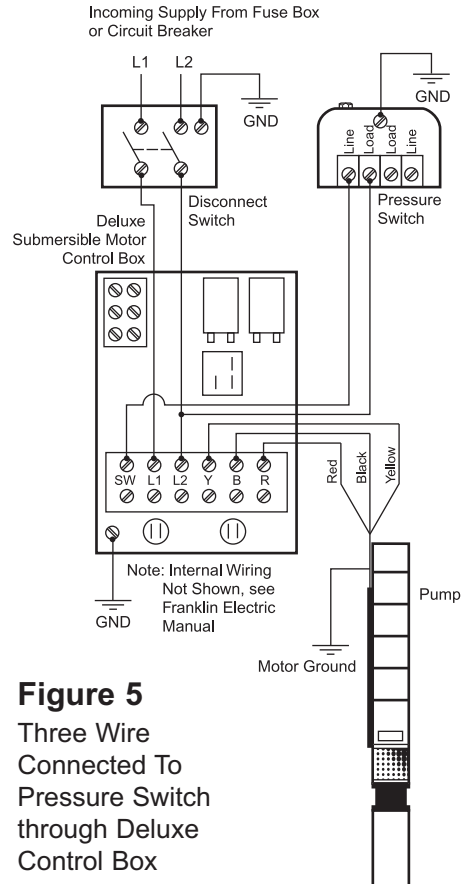
**Table 9**

Motor Rating		Minimum Rating of Generator			
		Externally Regulated		Internally Regulated	
HP	KW	KW	KVA	KW	KVA
5	3.7	15	18.75	7.5	9.4
7 1/2	5.5	20	25	10	12.5
10	7.5	30	37.5	15	18.75
15	11	40	50	20	25
20	15	60	75	25	31
25	18.5	75	94	30	37.5
30	22	100	125	40	50
40	30	100	125	50	62.5
50	37	150	188	60	75
60	45	175	220	75	94
75	55	250	313	100	125
100	75	300	375	150	188
125	93	375	469	175	219
150	110	450	563	200	250
175	130	525	656	250	313
200	150	600	750	275	344

# Single Phase Motors 5 Thru 15 HP

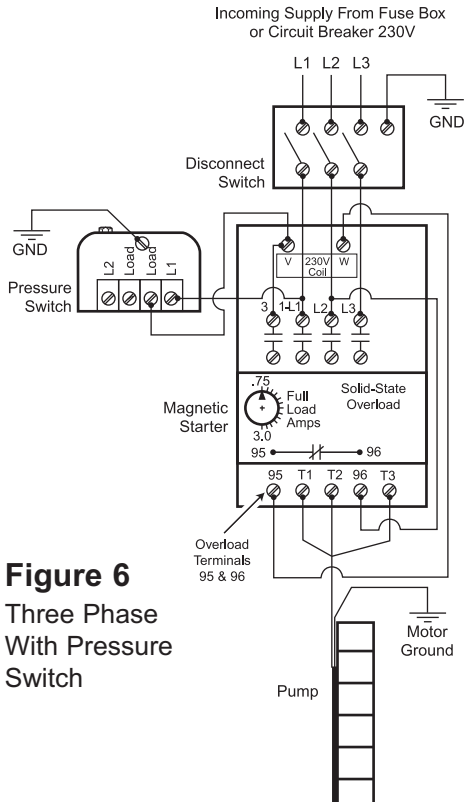


**Figure 4**  
Three Wire  
Connected to  
Control Box

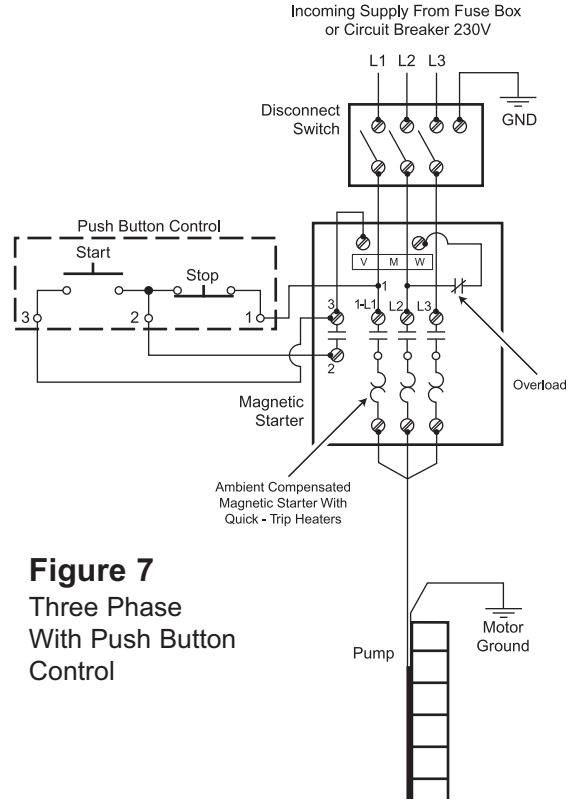


**Figure 5**  
Three Wire  
Connected To  
Pressure Switch  
through Deluxe  
Control Box

# Three Phase Motors



**Figure 6**  
Three Phase  
With Pressure  
Switch



**Figure 7**  
Three Phase  
With Push Button  
Control

## System Trouble Shooting

### Motor Does Not Start

Cause of Trouble	Checking Procedure	Correction Action
A. No power or incorrect voltage	Using voltmeter check the line terminals. Voltage must be $\pm 10\%$ of rated voltage	Contact power company if voltage is incorrect
B. Fuses blown or circuit breaker tripped	Check fuses for recommended size and check for loose, dirty, or corroded connections in fuse receptacle. Check for tripped circuit breaker	Replace with proper fuse or reset circuit breaker
C. Defective pressure switch	Check voltage at contact points. Improper contact of switch points can cause voltage less than line voltage	Replace pressure switch or clean points
D. Control box malfunction, 1 phase motor	See Franklin Electric Maint. and Installation Manual	Repair or replace
E. Defective cable or motor		
F. Defective wiring	Check for loose or corroded connections Check motor lead terminals with voltmeter for power	Correct faulty wiring or connections
G. Bound pump	Locked rotor conditions can result from misalignment between pump and motor or a sand bound pump. Amp readings 3 to 6 times higher than normal will be indicated	If pump will not start with several trials, it must be pulled and the cause corrected. New installations should always be run without turning off until water clears

### Motor Starts Too Often

Cause of Trouble	Checking Procedure	Correction Action
A. Pressure switch	Check setting on pressure switch and examine for defects	Reset limit or replace switch
B. Check valve, stuck open	Damaged or defective check valve will not hold pressure	Replace if defective
C. Waterlogged tank, (air supply)	Check air charging system for proper operation	Clean or replace
D. Leak in system	Check system for leaks	Replace damaged pipes or repair leaks

### Motor Runs Continuously

Cause of Trouble	Checking Procedure	Correction Action
A. Pressure switch	Switch contacts may be "welded" in closed position. Pressure switch may be set too high	Clean contacts, replace switch, or readjust setting
B. Low level well	Pump may exceed well capacity. Shut off pump, wait for well to recover. Check static and drawdown level from well head	Throttle pump output or reset pump to lower level Do not lower if sand may clog pump
C. Leak in system	Check system for leaks	Replace damaged pipes or repair leaks
D. Worn pump	Symptoms of worn pump are similar to those of drop pipe leak or low water level in well. Reduce pressure switch setting, if pump shuts off worn parts may be at fault. Sand is usually present in tank	Pull pump and replace
E. Loose or broken motor shaft	No or little water will be delivered if coupling between motor and pump shaft is loose or if a jammed pump has caused the motor shaft to shear off	Pull pump and replace
F. Pump screen blocked	Restricted flow may indicate a clogged intake screen on pump. Pump may be installed in mud or sand.	Clean screen and reset at less depth. It may be necessary to clean well
G. Check valve stuck closed	No water will be delivered if check valve is in closed position	Replace if defective
H. Control box malfunction, 1 phase motor	See Franklin Electric Maint. and Installation Manual	Repair or replace

### Motor Runs But Overload Protector Trips

Cause of Trouble	Checking Procedure	Correction Action
A. Incorrect voltage	Using voltmeter, check the line terminals. Voltage must be within $\pm 10\%$ of rated voltage	Contact power company if voltage is incorrect
B. Overheated protectors	Direct sunlight or other heat source can make control box hot causing protectors to trip. The box must not be hot to touch	Shade box, provide ventilation or move box away from heat source
C. Defective control box	See Franklin Electric Maint. and Installation Manual	Repair or replace
D. Defective motor or cable		
E. Worn pump or motor		
F. Improperly sized overload, 3 phase motor	Ambient compensated overload protection to be sized for service factor, not full load	Replace heaters

## Little Or No Liquid Delivered By Pump

Cause of Trouble	Checking Procedure	Correction Action
A. Faulty or incorrectly installed check valve	Inspect check valve. Is it installed backwards?	Replace if defective
B. Worn Pump	Reduce pressure switch setting - If pump shuts off, worn parts due to sand - usually present in tank - may be the problem	Pull pump & replace
C. Pump bound by sand	Amp readings 3 to 6 times higher than normal will be indicated	Pull pump, clean & reset depth or reverse rotation. 1 Phase motor: 5 thru 15 HP with voltage relay in control box. Switch the red & black leads in the control box. Turn on for 4 seconds, turn off for 1 minute, repeat 3 times. 3 Phase motor: Interchange any 2 cable leads where they connect to the lead terminals in the magnetic starter. Turn on for 4 seconds, turn off for 1 minute, repeat 3 times.
D. Incorrect motor rotation - 3 phase motor	Flow rate & pressure will be substantially reduced. For correct rotation the pump should jerk clockwise when looking into the pump discharge when started	Interchange any 2 cable leads where they connect to the lead terminals in the magnetic starter
E. Well contains air or gases	Drain tank. With valve open, turn pump on, if air or gases are present in the water, flow will be intermittent	Start and stop pump until a constant stream of water is delivered

## Owners Information

Name Of Dealer: \_\_\_\_\_ Phone: \_\_\_\_\_

Address: \_\_\_\_\_

Pump Model No: \_\_\_\_\_ GPM: \_\_\_\_\_ Total Dynamic Head: \_\_\_\_\_ (FT) Date Installed: \_\_\_\_\_

HP: \_\_\_\_\_ Volts: \_\_\_\_\_ Phase: \_\_\_\_\_ HZ: \_\_\_\_\_ Service Factor Amps: \_\_\_\_\_

AWG Cable Size: \_\_\_\_\_ Ft. \_\_\_\_\_

Well Diameter: \_\_\_\_\_ (IN). Well Depth: \_\_\_\_\_ (FT). Amount Of Casing: \_\_\_\_\_ (FT).

Static Water Level: \_\_\_\_\_ (FT). Well Drawdown: \_\_\_\_\_ (FT). Pump Setting: \_\_\_\_\_ (FT).

Pipe Size In Well: \_\_\_\_\_ (IN). Length Of Pipe In Well: \_\_\_\_\_ (FT).

Pipe Material: PVC \_\_\_\_\_ Galv. \_\_\_\_\_

Pipe Size From Well To Discharge Point: \_\_\_\_\_ (IN). Length Of Pipe From Well To Discharge Point: \_\_\_\_\_ (FT).

Pipe Material: PVC \_\_\_\_\_ Galv. \_\_\_\_\_

Pressure Tank: \_\_\_\_\_ U.S. Gallons: \_\_\_\_\_ Pressure Switch Setting Cut In PSI: \_\_\_\_\_ Cut Out PSI: \_\_\_\_\_

Check Valves at \_\_\_\_\_ @ \_\_\_\_\_ @ \_\_\_\_\_ @ \_\_\_\_\_ (FT).

Insulation Resistance \_\_\_\_\_ OHMS: \_\_\_\_\_ OHMS: \_\_\_\_\_ OHMS

Resistance Between Motor Leads - 3 Wire B/Y \_\_\_\_\_ OHMS B/R \_\_\_\_\_ OHMS Y/R \_\_\_\_\_ OHMS

## Thank You for Purchasing a WS Series Submersible Turbine Pump

We at Webtrol are constantly working on new products to make your job easier, while making your systems more efficient, reliable and affordable. Your opinion means a lot to us, so please let us know what you think about our WS Series Submersible Turbine Pump.



8417 New Hampshire Ave. | St. Louis, MO 63123

**Phone:** (314) 631-9200    **Fax:** (314) 631-3738    **E-mail:** comments@webtrol.com