



There when you need us most

MVPS SERIES GRINDER PUMPS

Cast Iron Grinder Pumps



The MVPS Series progressive cavity grinder pumps provide superior performance for the most demanding pressure sewer applications.

The quality and performance you expect, along with industry best lead times and personalized service, only from Webtrol!



Features and Benefits

- All cast iron construction
- Clog free stainless steel rotor and NBR stator
- Hardened, anti-wear grinding ring and cutter
- Double mechanical seal for better motor protection
- 1800 RPM, 4 pole motor
- Oil filled continuous duty motor
- 20' power cord
- Potted epoxy cord seal
- Built-in overload protection
- Available with 1.25" threaded connection or with rail kit
- Designed for pressure sewer systems
- Available in pre-packaged basin
- Ideal replacement for existing pressure sewer pumps

Performance

HP: 1.5 HP, 60Hz.
 Capacities to 12 GPM
 Heads to 360'
 Temperatures to 104° F

Typical Services

- Residential Wastewater
- Commercial Wastewater

Model	HP	Volt	Discharge	Cord Length	Dimensions (L x W x H)	Weight
MVPS15CE	1.5	230	1.25"	20'	16" x 12.5" x 28.5"	88 lbs.

3 phase model available

MVPS SERIES GRINDER PUMPS

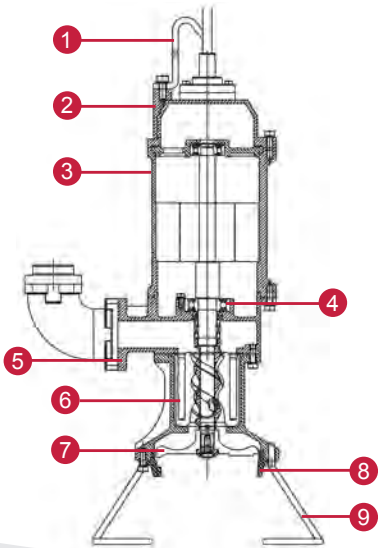
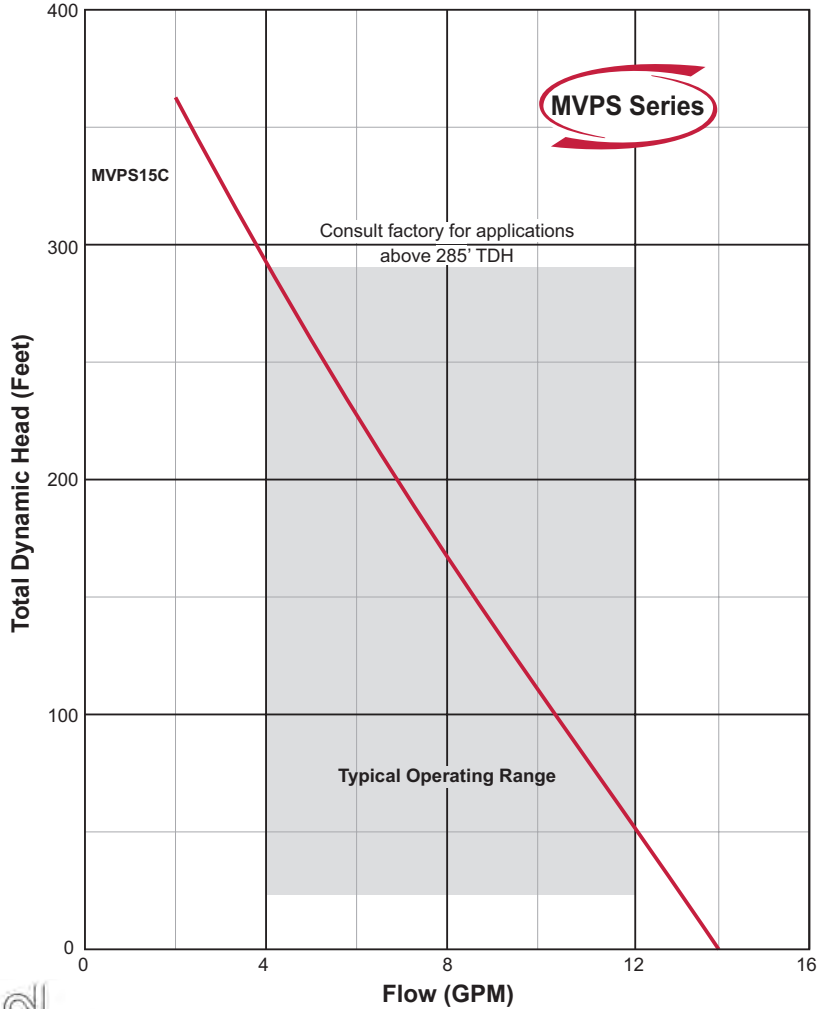

CONSTRUCTION MATERIALS		
Number	Part	Material
1	Handle	Steel
2	Top Cover	Cast Iron
3	Motor Housing	Cast Iron
4	Mechanical Seal	Silicon Carbide/Silicon Carbide
5	Pump Volute	Cast Iron
6	Rotor/Stator	304 SS/Buna-N
7	Cutter	440 SS
8	Cutter Ring	440 SS
9	Base Legs	304 SS