

# WEBTROL

*There when you need us most*

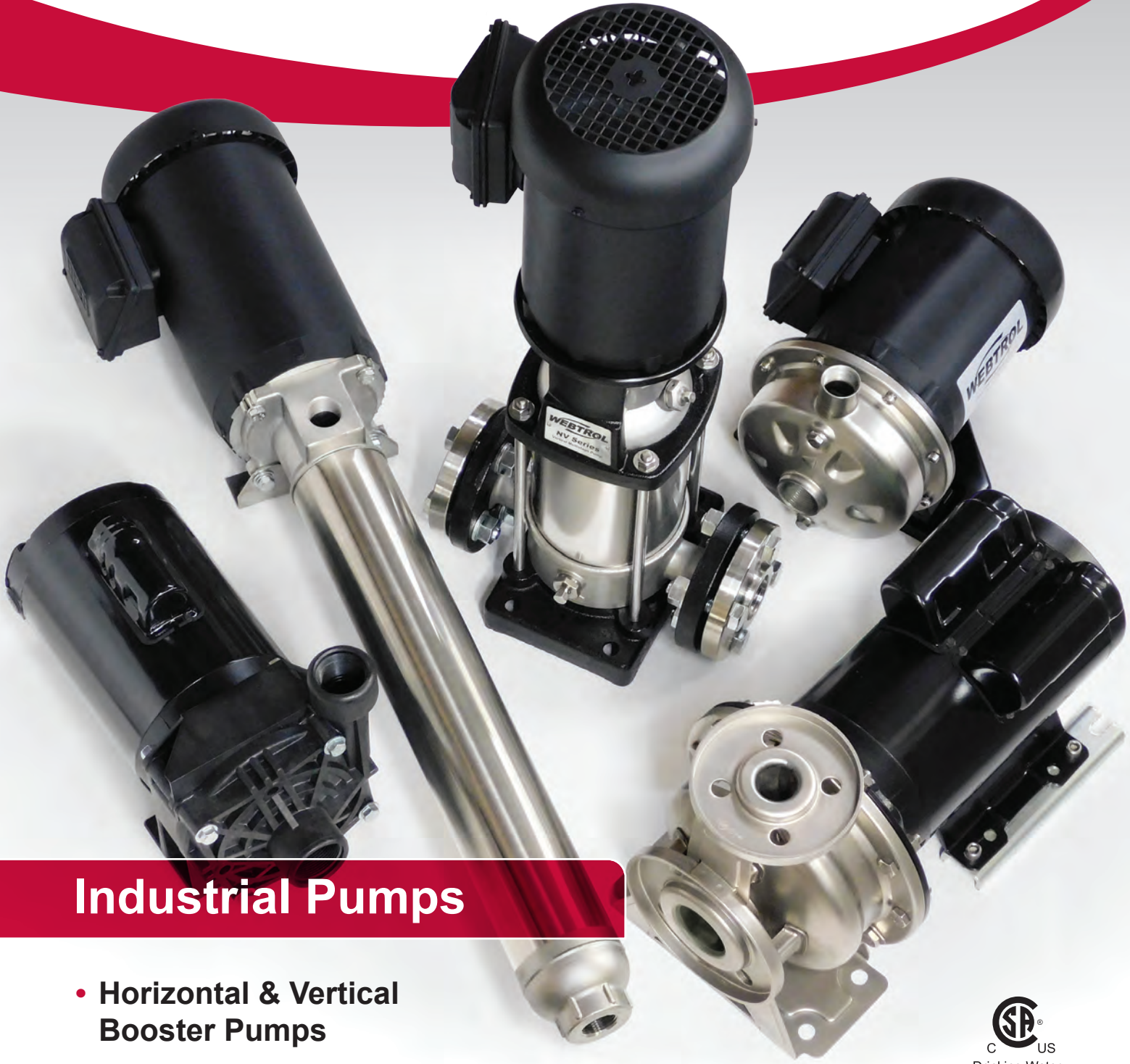

## Industrial Pumps

- Horizontal & Vertical Booster Pumps
- End Suction Centrifugal Pumps

  
C US  
Drinking Water  
NSF/ANSI 61  
NSF/ANSI 372



**Booster and Centrifugal Surface Pumps  
for Industrial, Commercial, Municipal,  
and Agricultural Applications**

**(800) 769-7867**

8417 New Hampshire Ave. | St. Louis, MO 63123

**Web:** [webtrol.com](http://webtrol.com) | **E-mail:** [customerservice@webtrol.com](mailto:customerservice@webtrol.com) | **Fax:** (314) 631-3738

*WEBTROL* is a Division of Weber Industries, Inc.



There when you need us most

## TABLE OF CONTENTS

<b>EZ Series Boosters</b> .....	3 - 19	<b>FC Series Centrifugals</b> .....	71 - 81
Construction & Design.....	4 - 5	Construction Materials.....	72
Curves		Curves	
G & H Series Family.....	6	FC Series Family.....	72
G Series Group.....	7 - 11	FC Series Group.....	73 - 76
H Series Group.....	12 - 16	Dimensions.....	77 - 81
Dimensions.....	17 - 18		
Repair Parts.....	19	<b>TC Series Centrifugals</b> .....	83 - 88
		Curves.....	90
<b>NV Series Vertical Boosters</b> .....	21 - 43	Construction Materials.....	90
Construction & Design.....	68	Dimensions.....	91
Curves & Dimensions			
NV Series Family.....	23	<b>2TC Series Stainless Steel 2-Stage Centrifugals</b> .....	89 - 91
NV6 - NV400 Series Group.....	24 - 43	Curves.....	90
		Dimensions.....	91
<b>HT Series Boosters</b> .....	45 - 51		
Construction & Design.....	46 - 47	<b>SP Series Stainless Steel Self-Priming Centrifugals</b> .....	93 - 96
Curves		Curves	
HT Series Family.....	48	PC Family Group.....	94
H60 - H80 Series Group.....	49 - 50	PC Group Curves.....	95
Dimensions.....	51	Dimensions.....	96
<b>In-Line Boosters</b> .....	53 - 62	<b>EP Series Stainless Steel Sump Pumps</b> .....	97 - 99
Construction & Design.....	54 - 55	Curves.....	98
Curves		Construction Materials.....	98
T Series Family.....	56	Installation & Dimensions.....	99
T5 - T35 Series Group.....	113 - 119		
Dimensions.....	62	<b>SS Series Stainless Steel Sewage Pumps</b> .....	101
		Curves	
<b>ACE Cast Iron Centrifugals</b> .....	63 - 64	Single Channel Curves.....	102
Curves.....	64	Vortex Curves.....	102
Dimensions.....	64	Construction Materials.....	103
<b>PC Series Centrifugals</b> .....	65 - 70	<b>Warranty</b> .....	104
Curves.....	66 - 69		
Dimensions.....	70	<b>Conditions Of Sale</b> .....	105
Construction & Design.....	70		



## EZ SERIES BOOSTER PUMPS

### Cast Iron and Stainless Steel Booster Pumps



## EZ Series

EZ Series pumps are carefully hand assembled, then individually checked & tested, to provide you with reliable solutions for industrial, commercial, and agricultural applications.

The quality and performance you expect, along with industry best lead times and personalized service, only from Webtrol!

### Features and Benefits

- 316 stainless steel and cast iron fitted models
- 316 stainless steel hex shaft, coupling, and pump housing
- Glass filled Delrin®, Polycarbonate or Noryl® impellers
- Injection molded, Polycarbonate, or Noryl®I diffusers with stainless steel wear rings

### Performance

HP Range: .5 to 5 HP, 60Hz  
Capacities to 40 GPM  
Pressures to 500 PSI  
Temperatures to 180 °F

### Typical Services

- Reverse Osmosis
- Deionization
- Car Wash
- Washdown
- Water Boosting
- Jockey Pump

### BOOSTER PUMPS

#### Construction & Design Features

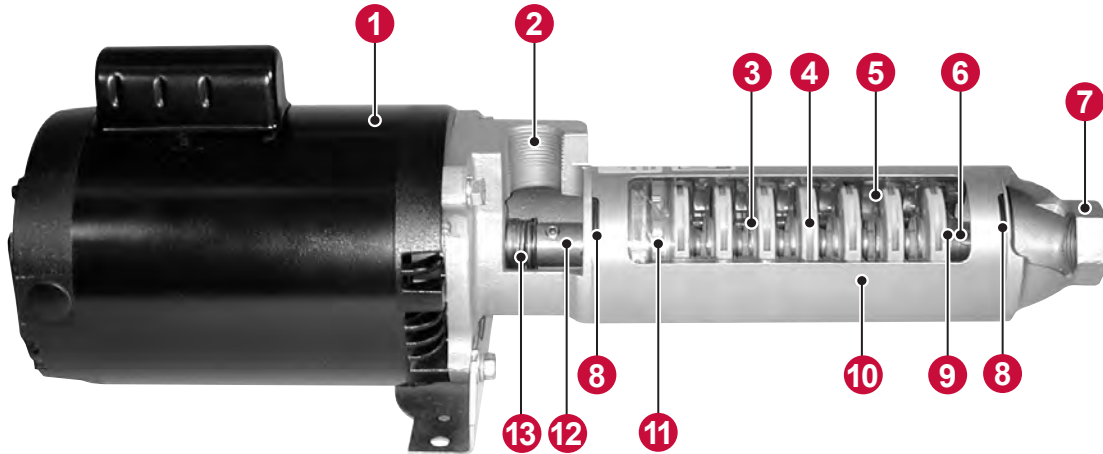

**Cast Iron**

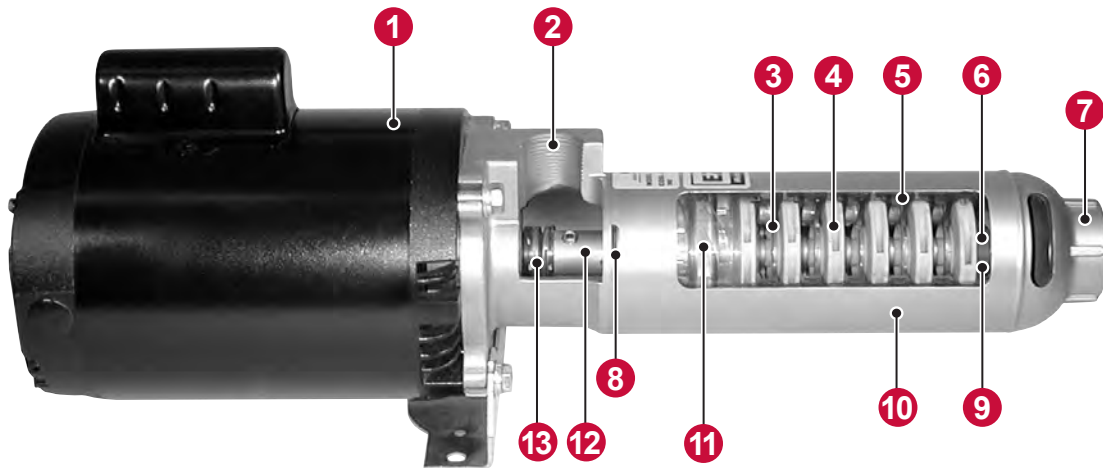

**Stainless Steel**

Construction Materials		
Part	Cast Iron	316 SS
Inlet/Motor Bracket	Cast Iron	316 SS
Discharge Housing	Cast Iron	316 SS
Pump Housing	304 SS	316 SS
Impellers	Thermoplastic	Thermoplastic
Diffusers	Thermoplastic	Thermoplastic
Wear Rings	316 SS	316 SS
Shaft & Coupling	316 SS	316 SS
Mechanical Seal	Carbon/Ceramic	Carbon/Ceramic
O-Rings	Buna-N	Viton™

Inlet & Discharge Size		
Part	Series (GPM)	Size (FNPT)
Inlet/Discharge	5, 10, 15	1"
Inlet/Discharge	20, 35	1 1/2"

## BOOSTER PUMPS

### Construction & Design Features

#### 1 Motor

The motor is a “C” face, 3450 RPM, 50 or 60 cycle, single or three phase, open drip proof (TEFC available) with long life thrust bearings, sized to support the thrust loads generated by the pump. Motors through 3 HP are NEMA Standard 56J frame with a threaded shaft and greased for life ball bearings. 5 HP motors are foot mounted 184CZY frame with a keyed shaft and greasable high thrust angular contact bearings.

#### 2 Inlet/Motor Bracket

The inlet / motor bracket is cast iron or investment cast stainless steel depending on the type of construction you choose. All inlet connections are female NPT.

#### 3 Diffuser Wear Rings

Stainless steel wear rings are molded into each diffuser at all critical wear points, maintaining tight clearances for high efficiencies.

#### 4 Impellers

High strength glass filled Delrin® or polycarbonate thermoplastic impellers provide pulse free pressure boost. All impellers are injection molded and machined to insure dimensional accuracy and balance. Noryl impellers are available upon request.

#### 5 Diffusers

High strength polycarbonate diffusers are injection molded, concentrically aligned, providing perfectly aligned, clean, smooth water passages for higher efficiencies. Noryl® diffusers are available upon request.

#### 6 Shaft

Stainless steel hex shaft is cold drawn to exacting tolerances, to eliminate shaft run out for vibration free operation.

#### 7 Discharge

The discharge is cast iron or investment cast stainless steel depending on the type of construction you choose. All discharge connections are female NPT.

#### 8 O-Rings

Positive sealing Buna-N o-rings are used to seal off both ends of the pump housing on cast iron models. A Viton™ o-ring is used to seal the inlet side of the pump housing on stainless steel models.

#### 9 Shaft Sleeve Running Bearing

316 Stainless steel running bearing is water lubricated and cooled. The shaft sleeve runs inside of either a Rulon® (stainless steel models) or brass (cast iron models), sleeve bearing, that has been molded into the top diffuser for greater efficiency. Each bearing is machined to precision tolerances and concentricity. Intermediate bearings are used on pumps that may require additional support.

#### 10 Pump Housing

Thick wall stainless steel tubing is used on all models. Cast iron models are threaded on both ends. Stainless steel models are threaded on the inlet side with a discharge that has been machine welded to the tube on the other end.

#### 11 Rotating Assembly

The entire rotating assembly, consisting of impellers, diffusers, top and bottom plates, bearings, shaft and coupling, is easily field replaceable.

#### 12 Coupling

Stainless steel coupling has interference fit onto the pump shaft and pinned to lock in place. Depending on the motor frame size, the coupling either screws onto the motor shaft or slips onto the motor shaft and is keyed in place. Set screws lock the coupling to the motor shaft.

#### 13 Mechanical Seal

The spring loaded, positive sealing, mechanical seal has a ceramic stationary face and a carbon rotating face. Metal components on the rotating half are stainless steel and the elastomers are Buna-N (Nitrile) on cast iron models and Viton on stainless steel models. The standard seal will handle inlet pressures up to 100 PSI, while an optional seal is available for pressures up to 250 PSI.



There when you need us most

**EZ Series**

## SERIES FAMILY CURVES

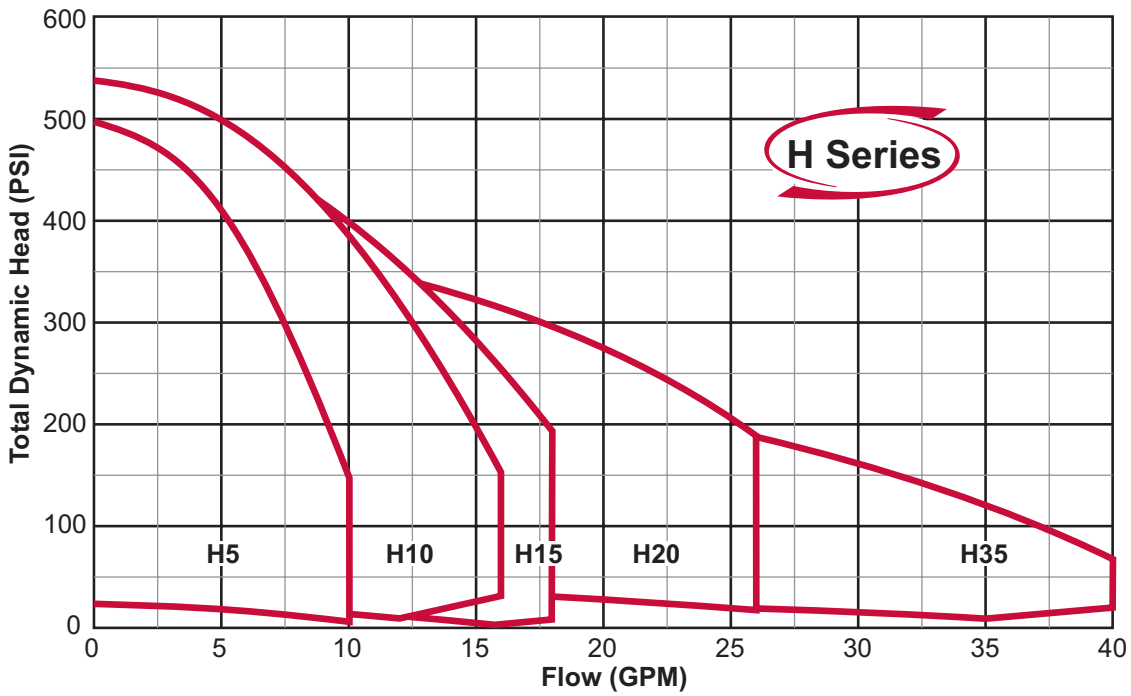
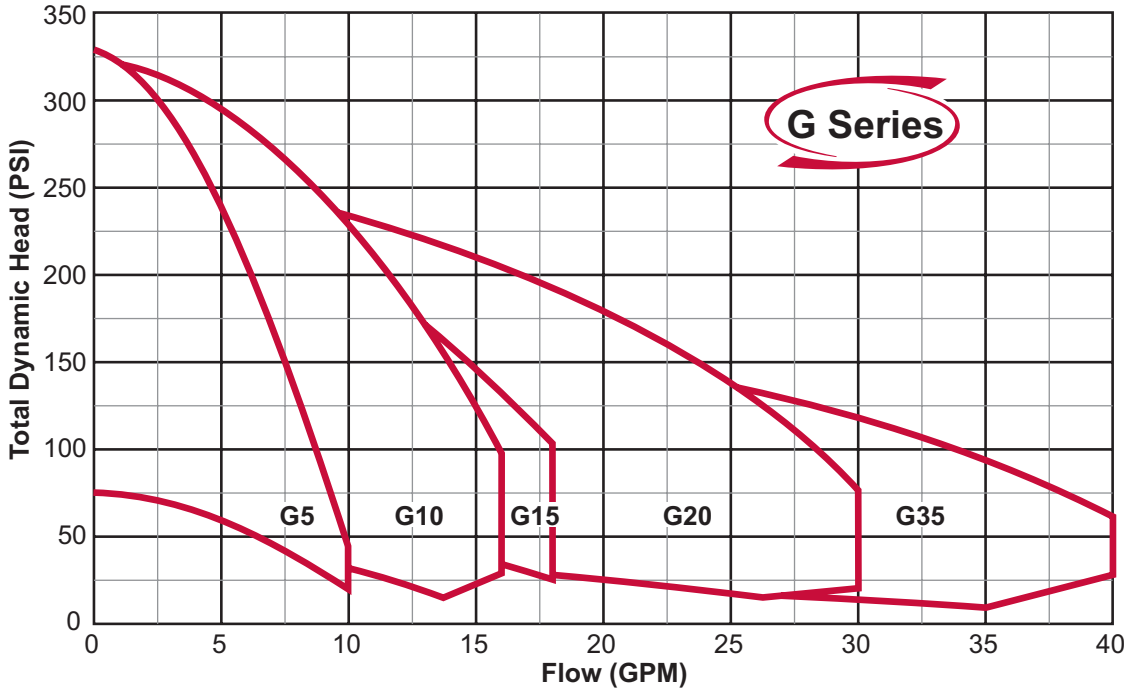



## G5 SERIES GROUP CURVES

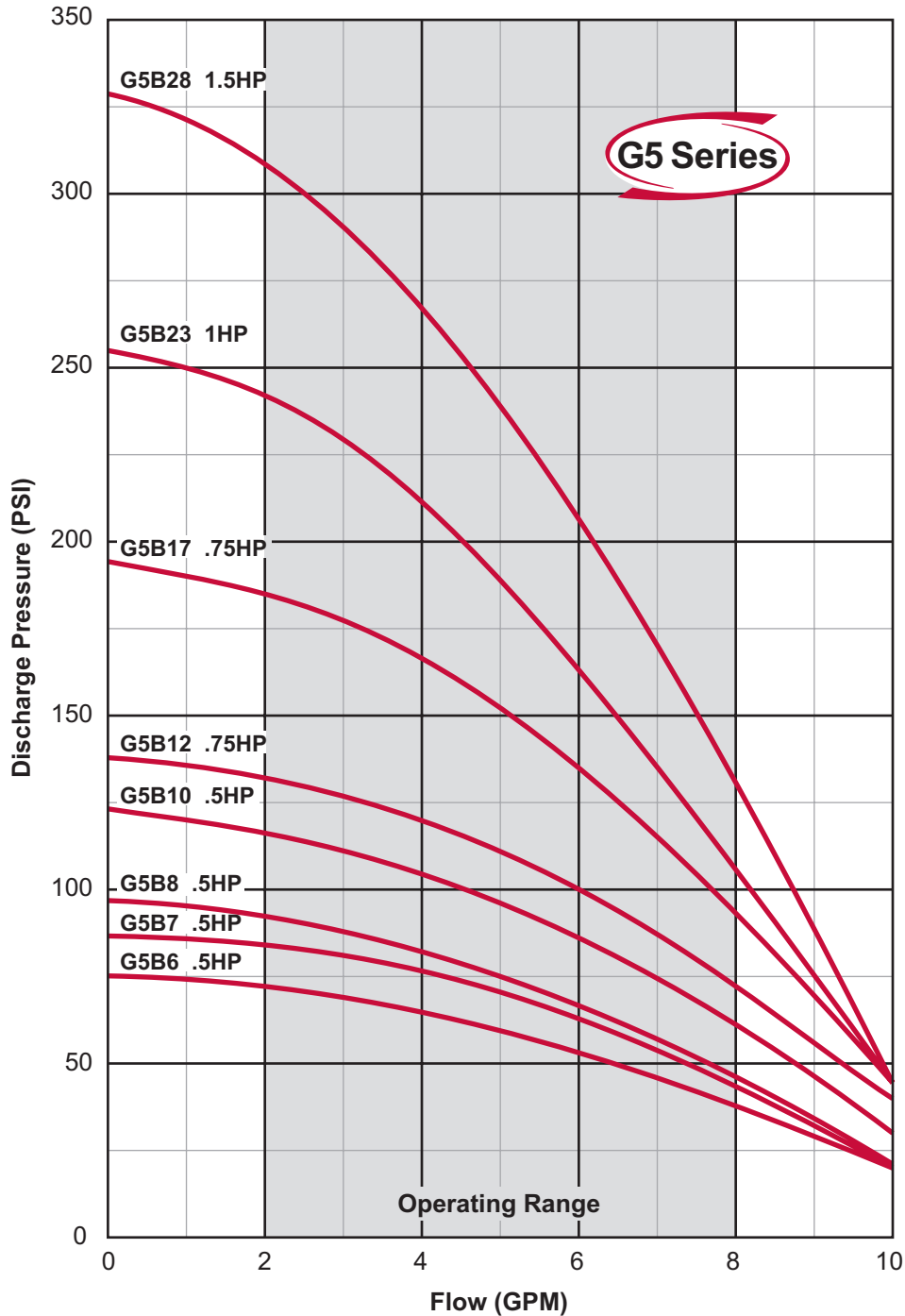

**Note:**

Curves are based on 60 Hz 3450 rpm motors. 50 Hz 2875 rpm curves are available. These curves are for general guidance only, individual pump curves are available upon request. A certified curve may be requested for an additional cost. Webtrol will build pumps to fit your specific needs, contact factory for pricing.



There when you need us most

**EZ**Series

## G10 SERIES GROUP CURVES

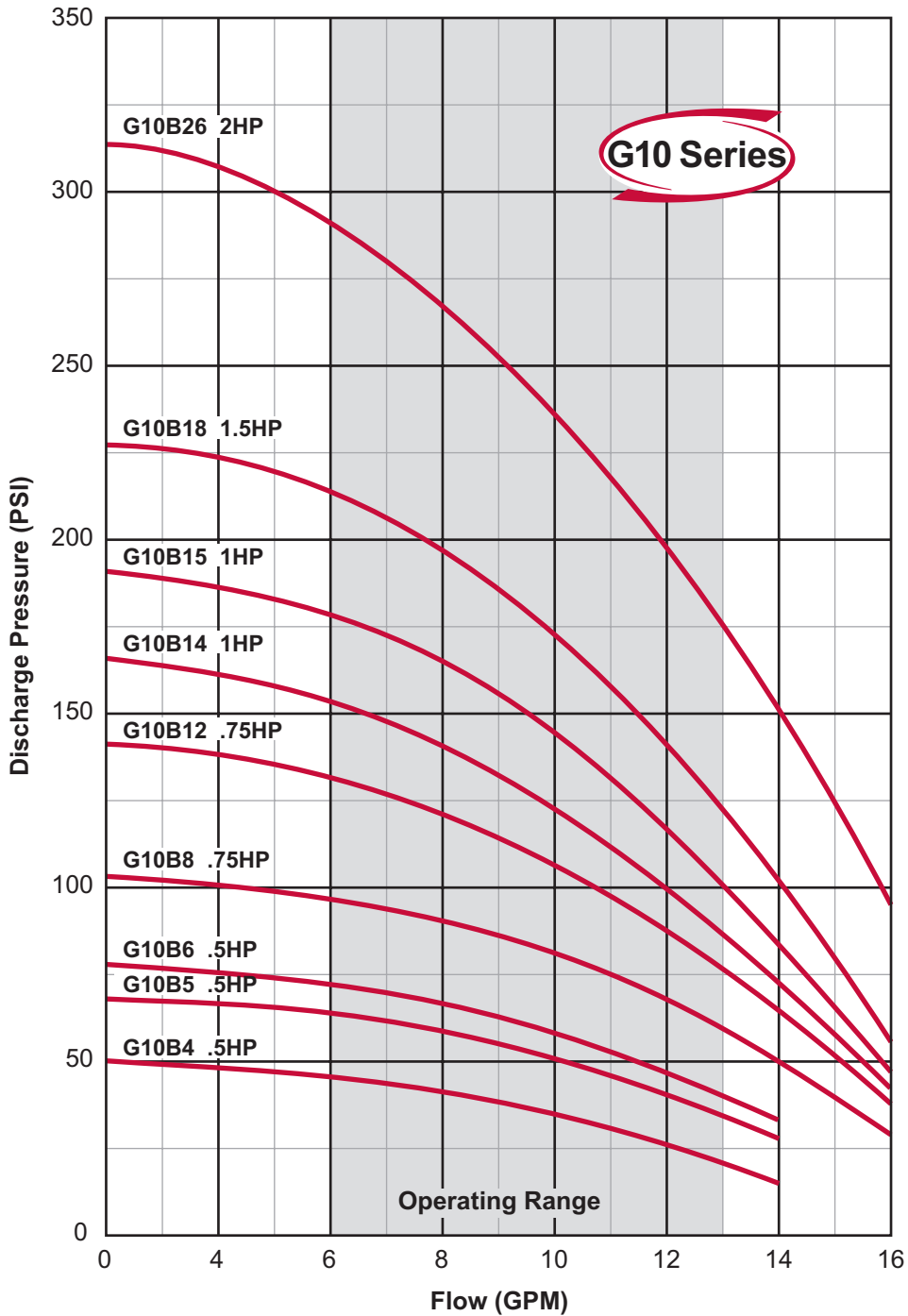

**Note:**

Curves are based on 60 Hz 3450 rpm motors. 50 Hz 2875 rpm curves are available. These curves are for general guidance only, individual pump curves are available upon request. A certified curve may be requested for an additional cost. Webtrol will build pumps to fit your specific needs, contact factory for pricing.



There when you need us most

## G15 SERIES GROUP CURVES

**EZ**Series

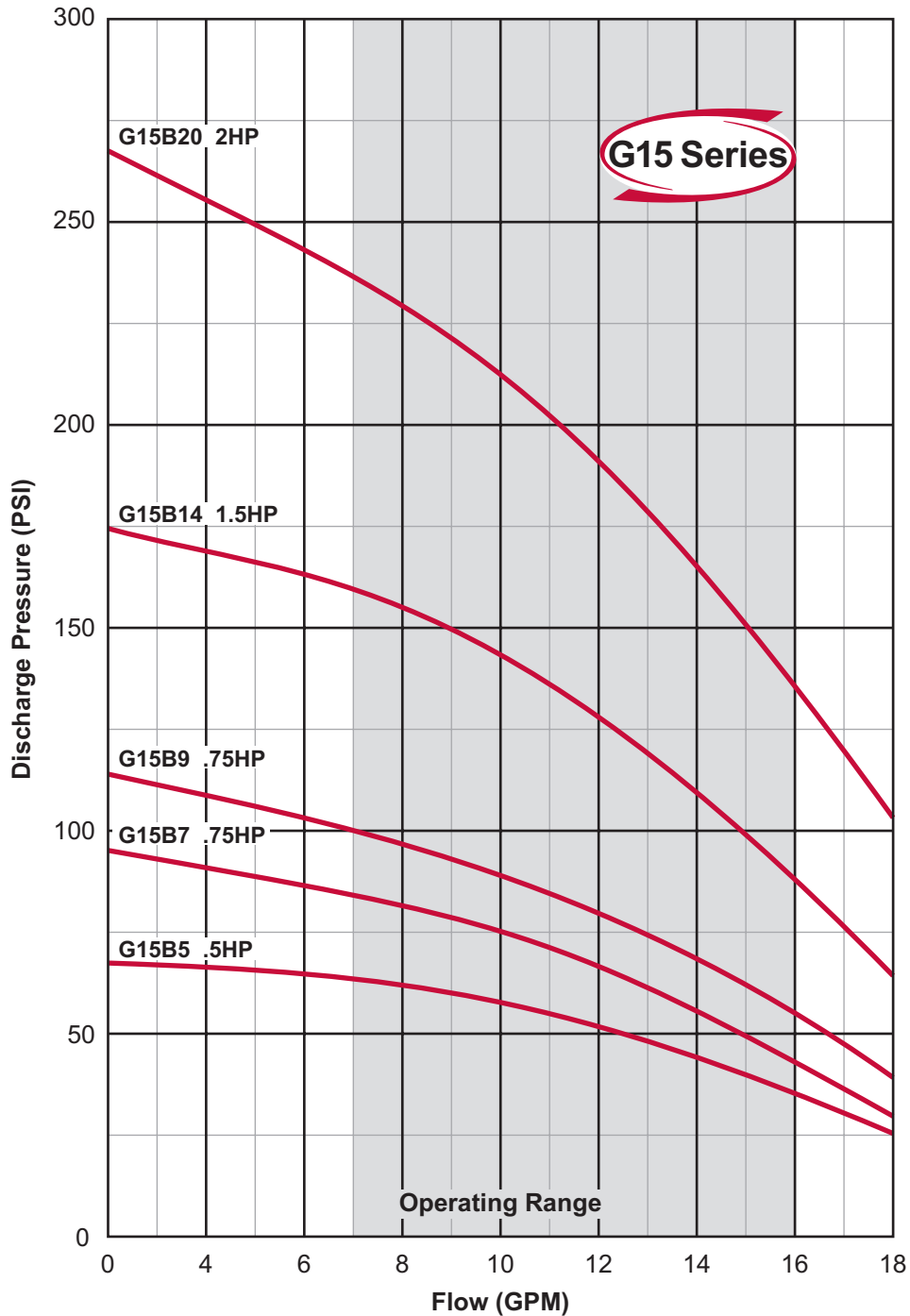

**Note:**

Curves are based on 60 Hz 3450 rpm motors. 50 Hz 2875 rpm curves are available. These curves are for general guidance only, individual pump curves are available upon request. A certified curve may be requested for an additional cost. Webtrol will build pumps to fit your specific needs, contact factory for pricing.

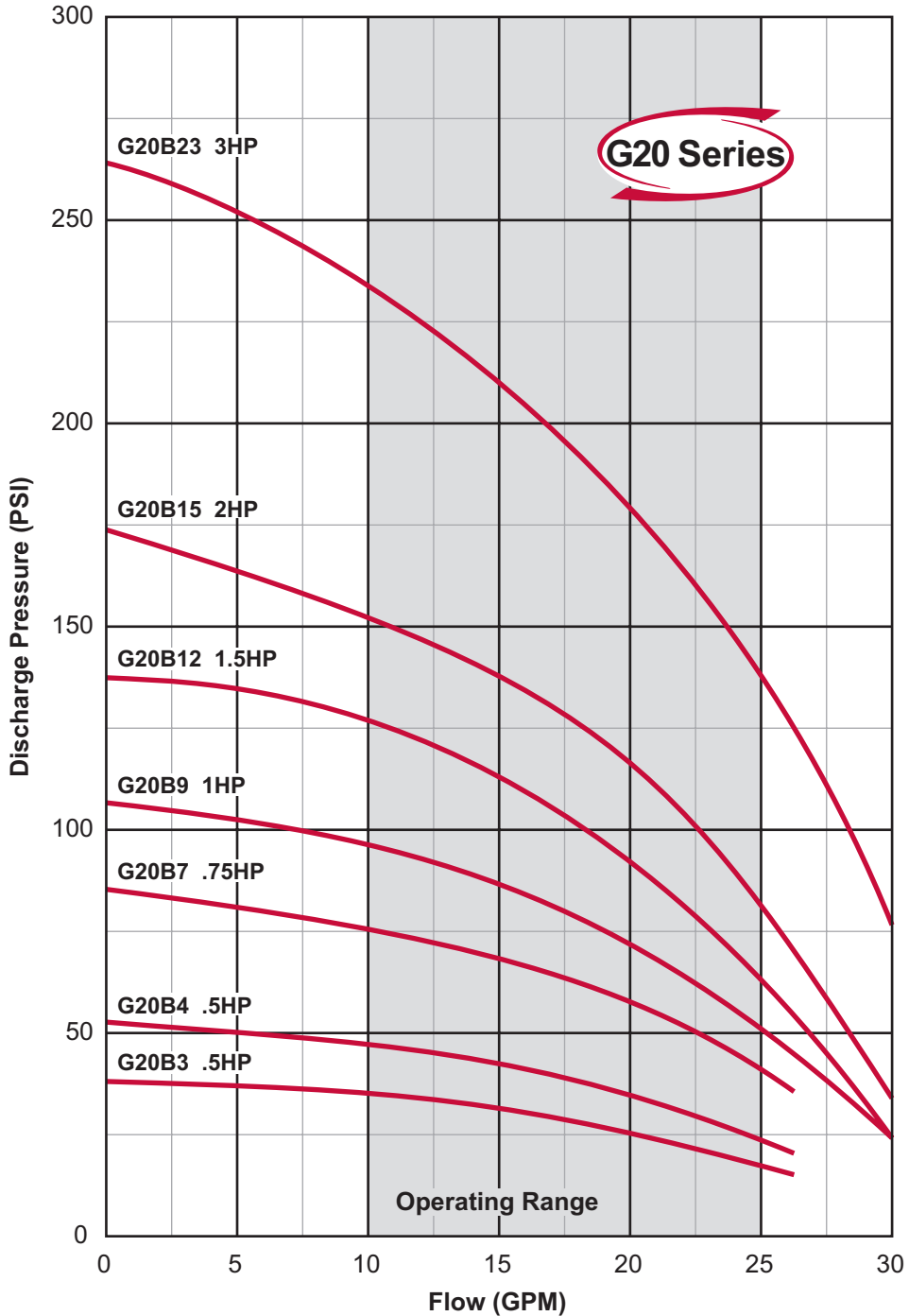

**Note:**

Curves are based on 60 Hz 3450 rpm motors. 50 Hz 2875 rpm curves are available. These curves are for general guidance only, individual pump curves are available upon request. A certified curve may be requested for an additional cost. Webtrol will build pumps to fit your specific needs, contact factory for pricing.

## G35 SERIES GROUP CURVES

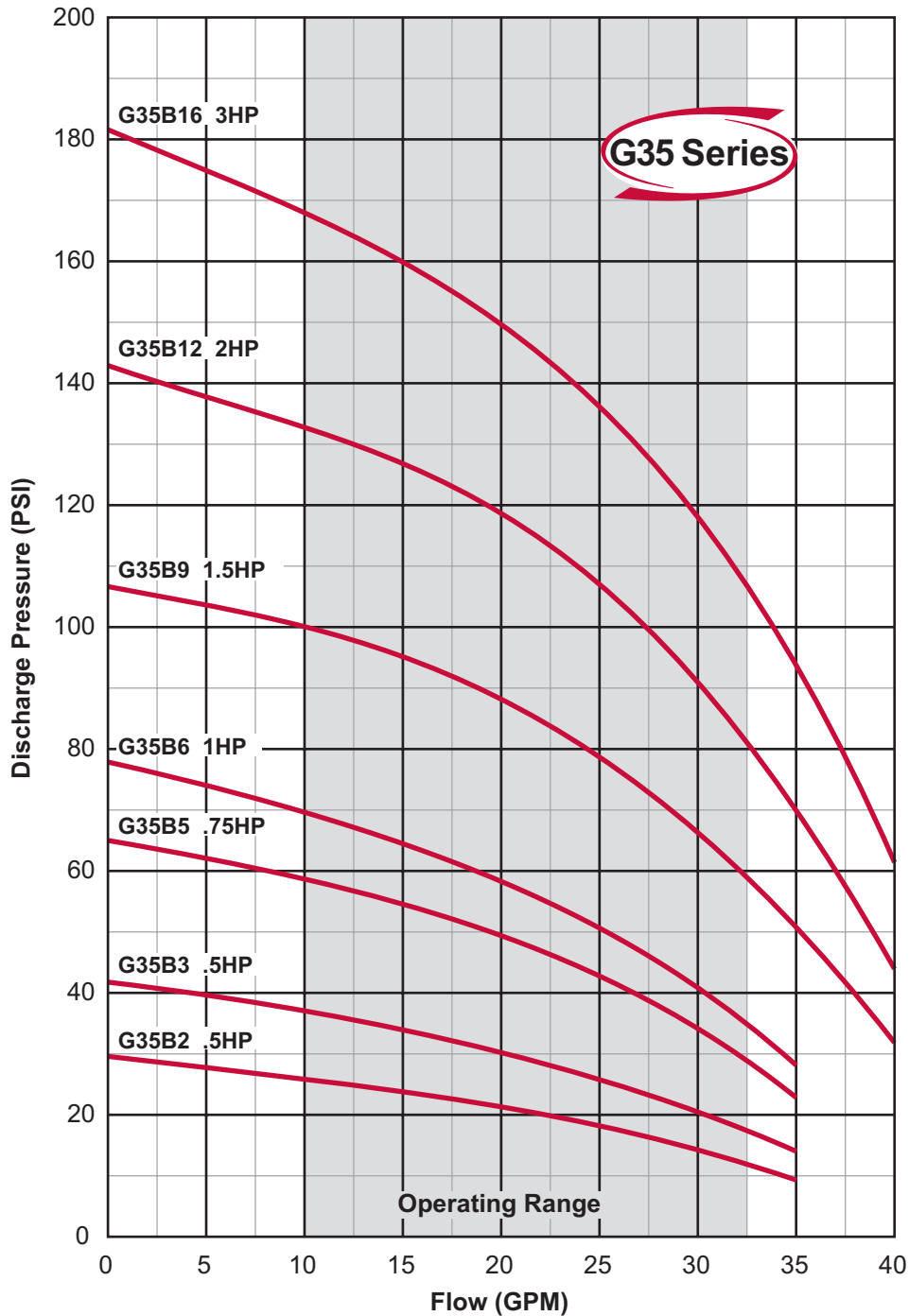

**Note:**

Curves are based on 60 Hz 3450 rpm motors. 50 Hz 2875 rpm curves are available. These curves are for general guidance only, individual pump curves are available upon request. A certified curve may be requested for an additional cost. Webtrol will build pumps to fit your specific needs, contact factory for pricing.



There when you need us most

**EZ** Series

## H5 SERIES GROUP CURVES

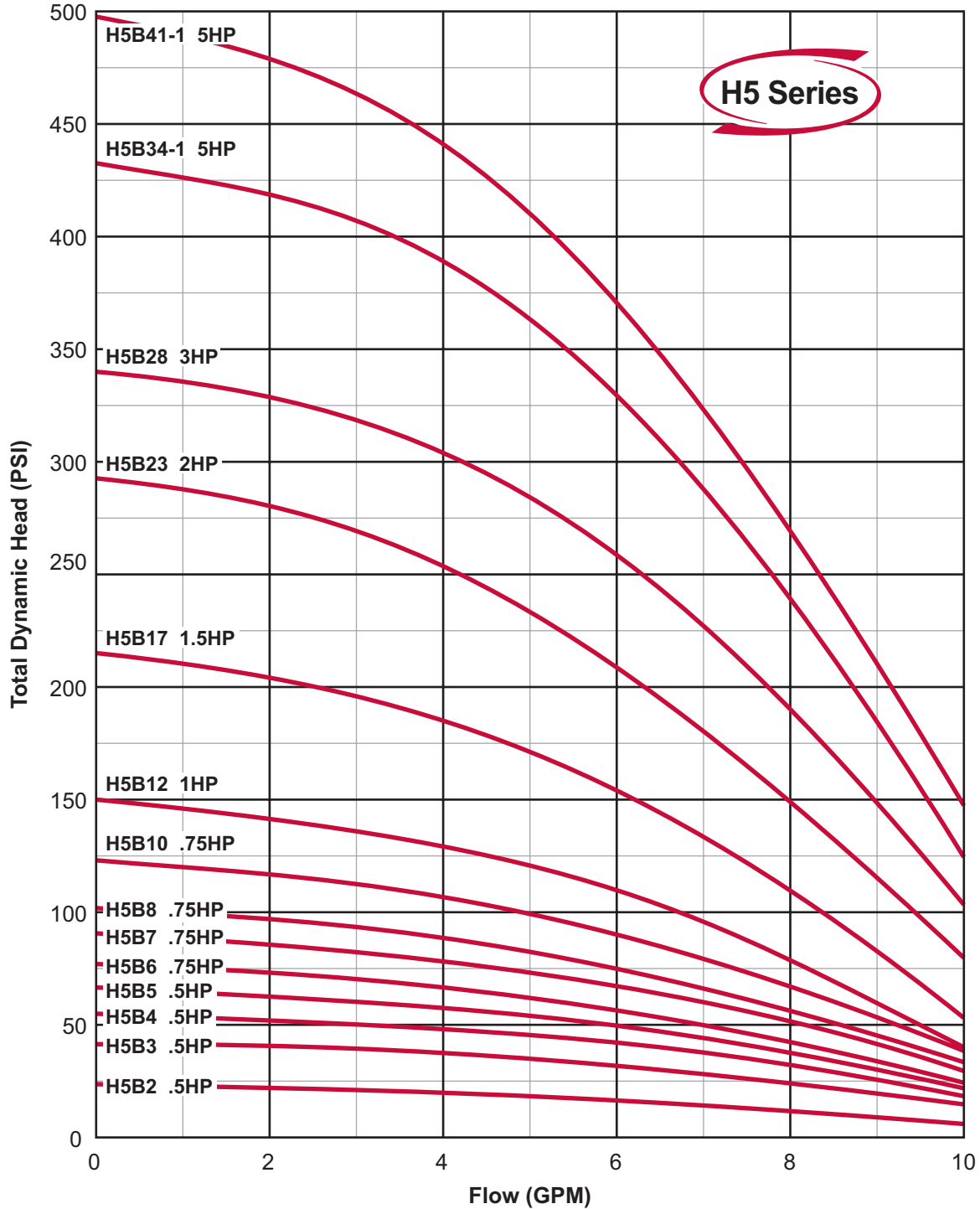

## H10 SERIES GROUP CURVES

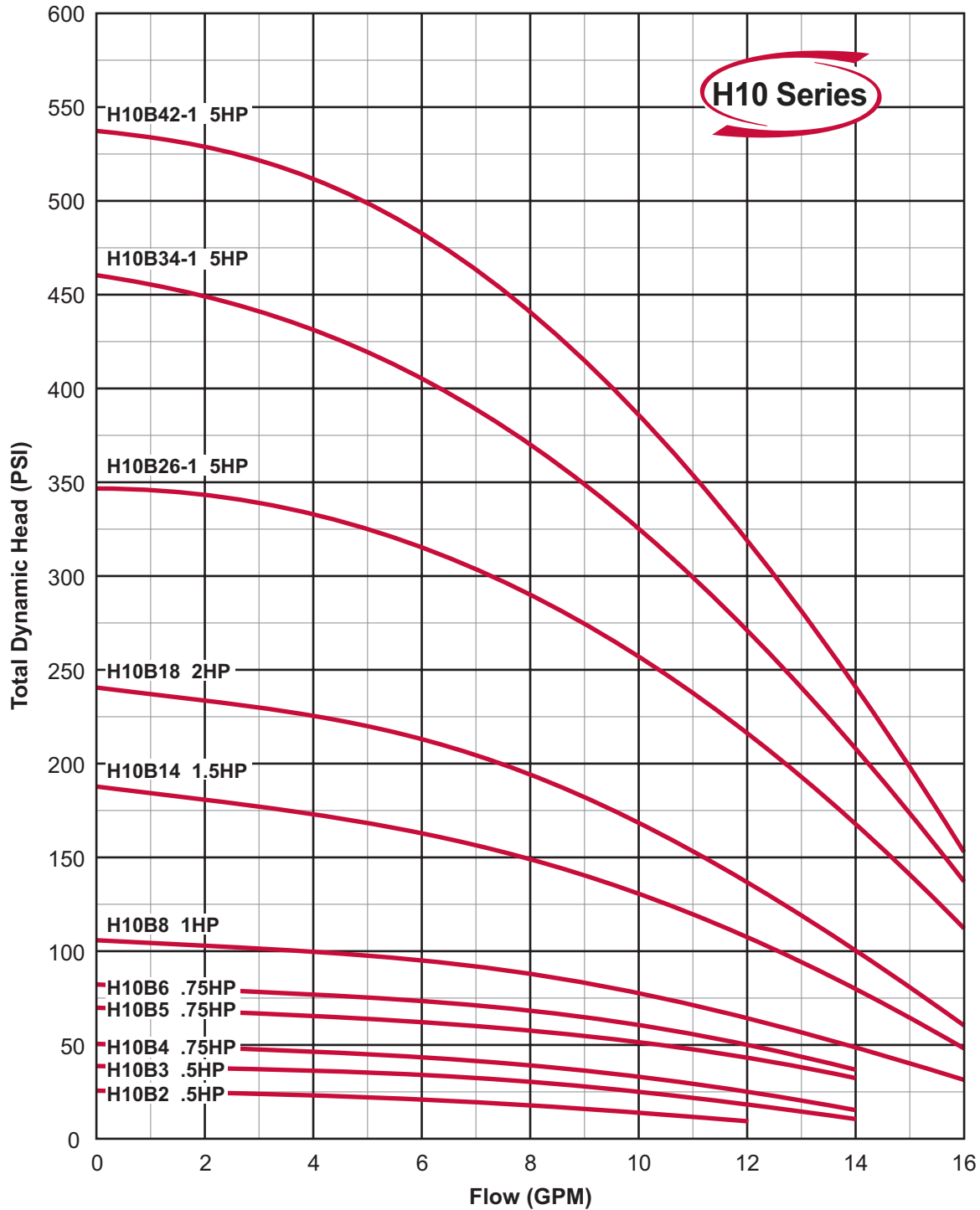



There when you need us most

**EZ** Series

## H15 SERIES GROUP CURVES

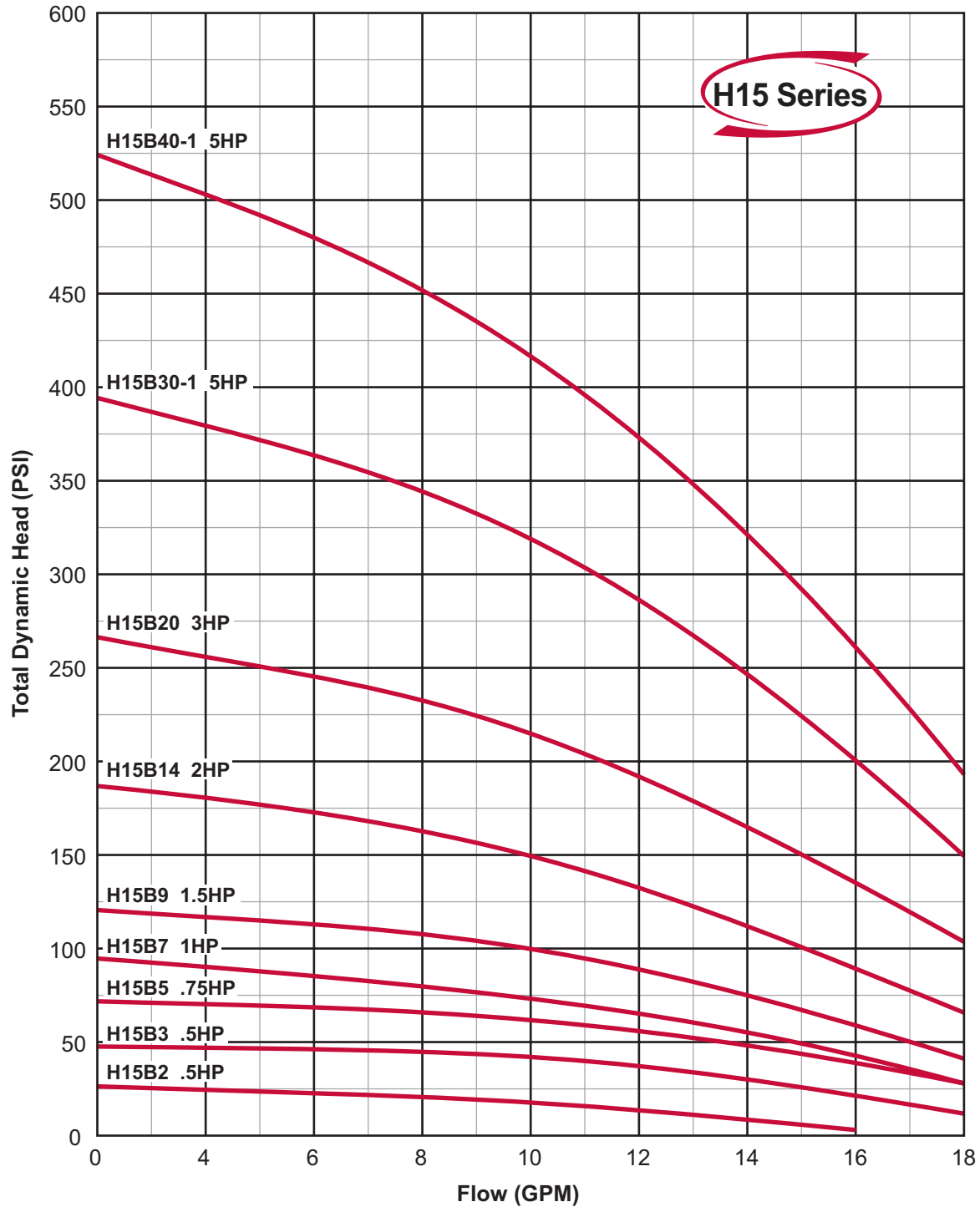





There when you need us most

## H2O SERIES GROUP CURVES

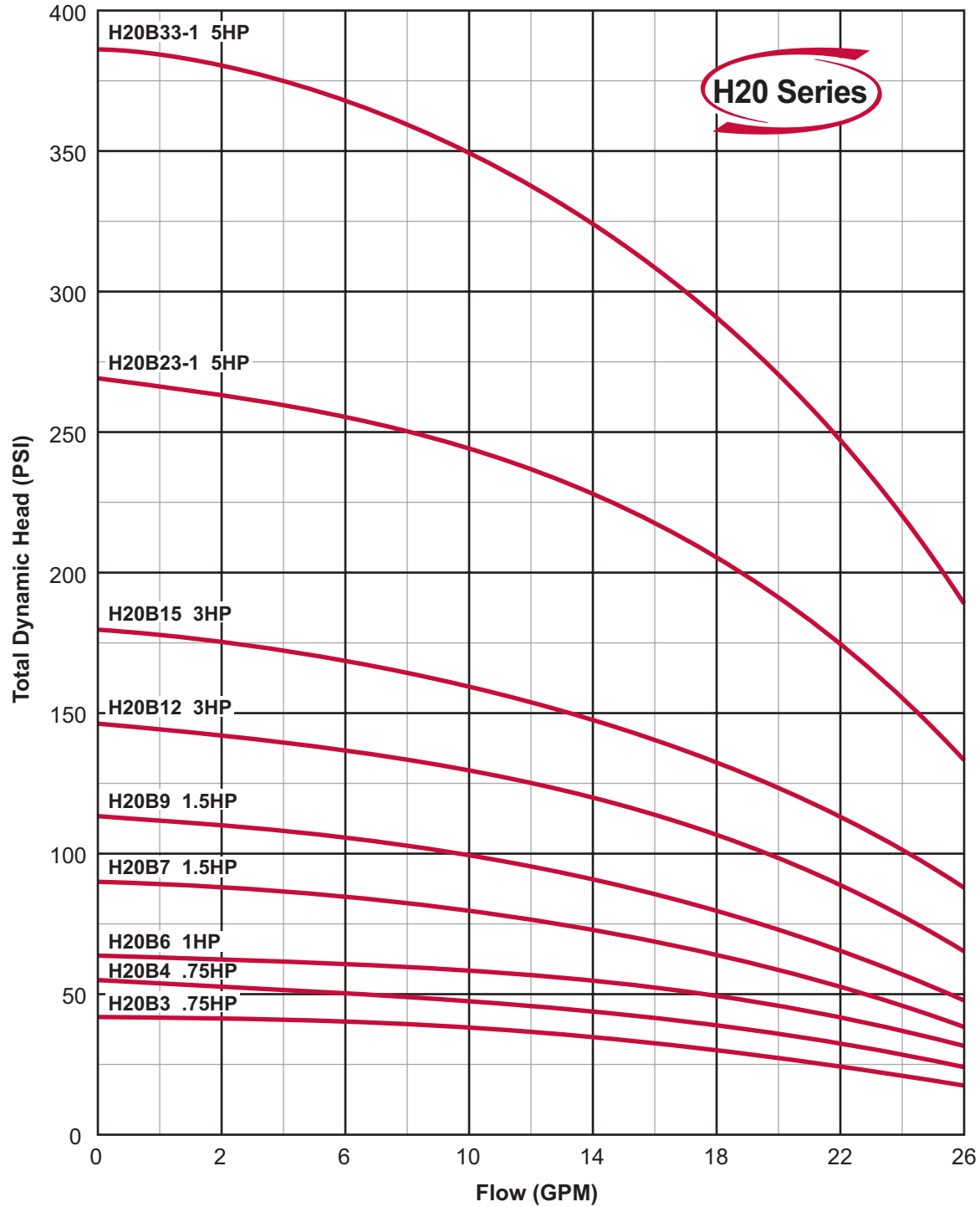



There when you need us most

**EZ** Series

### H35 SERIES GROUP CURVES

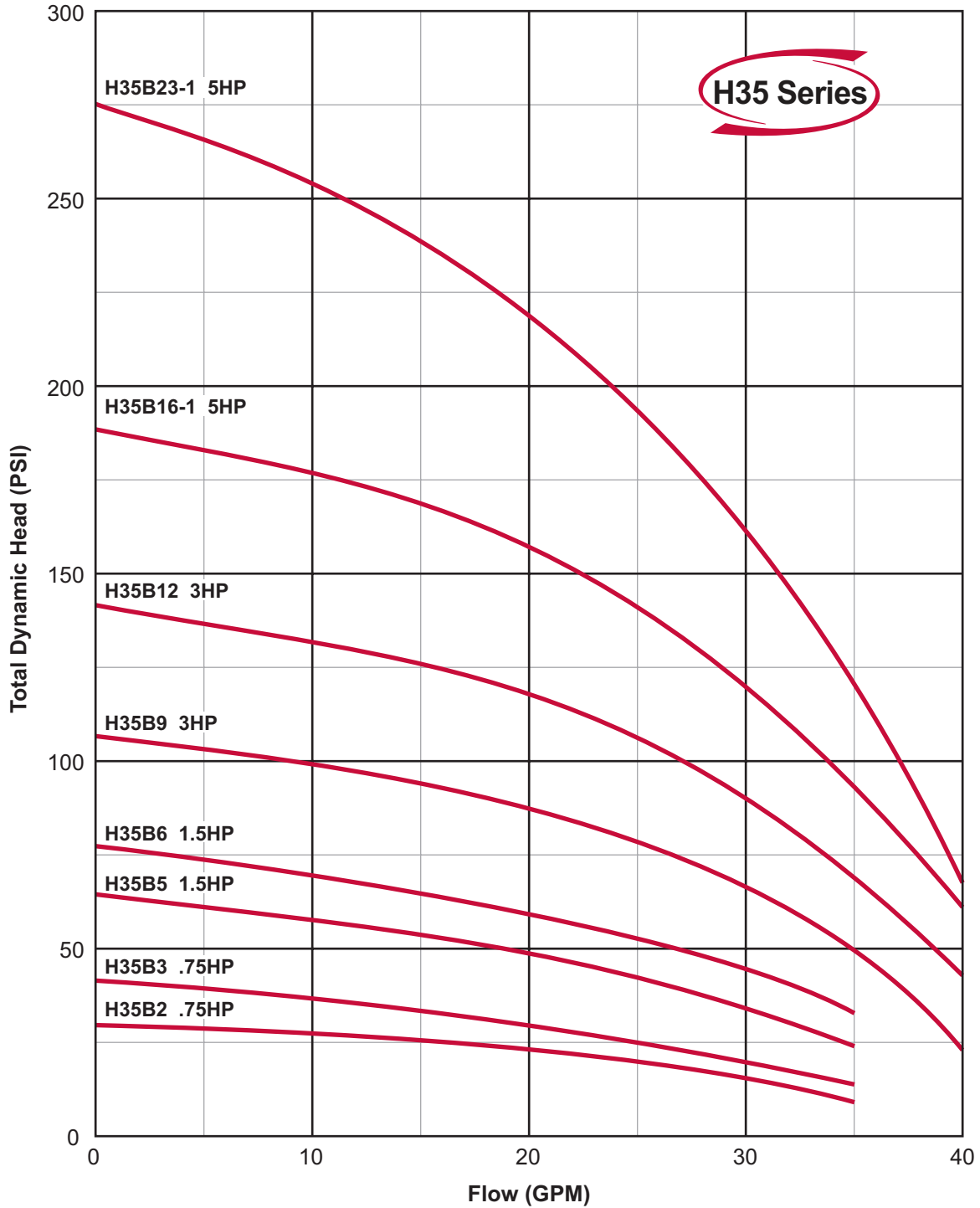

## EZ BOOSTER DIMENSIONS

**EZ** Series

### Cast Iron and Stainless Steel Booster Pumps

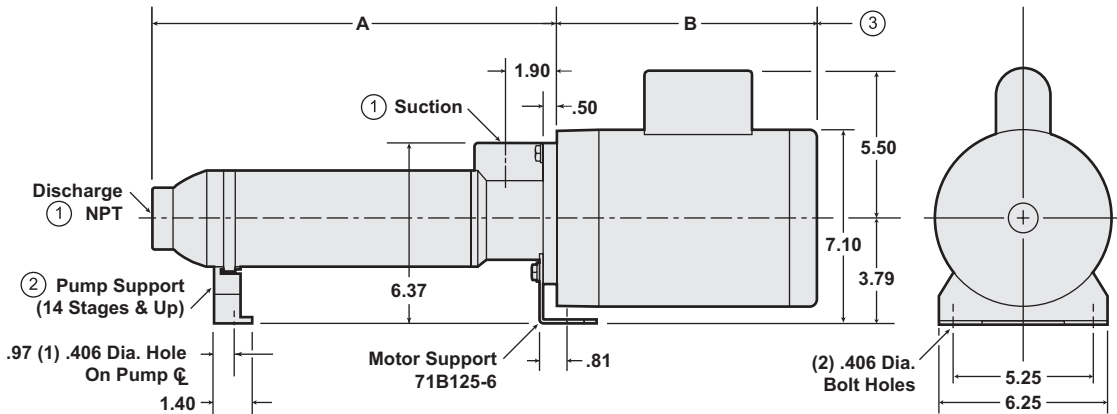

**1/3 - 3 HP Models**

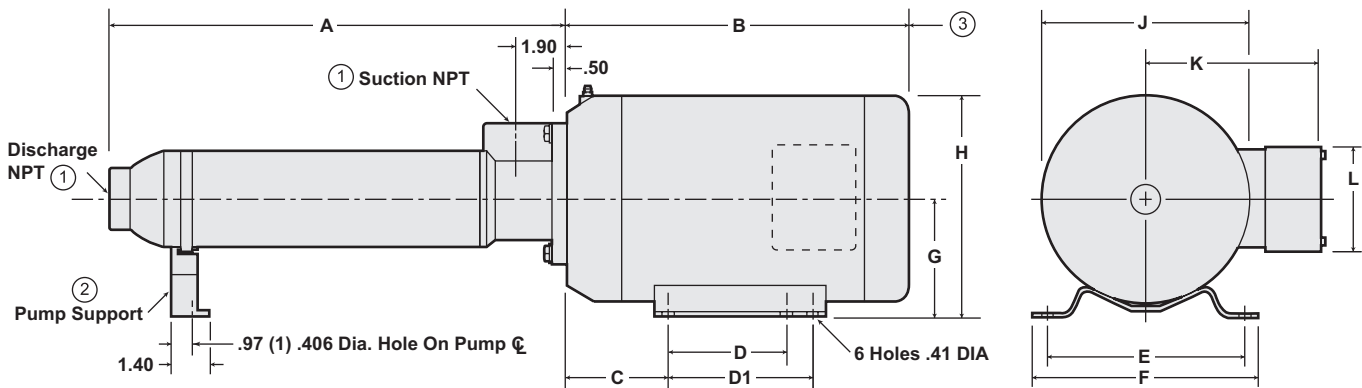

**5 HP Models**

1. The inlet and discharge thread size for C.I. and stainless steel models in the 5, 10, 15 GPM pump sizes is 1" NPT; The 20 and 35 GPM pump size is 1 1/2" NPT.
2. Pump models that are 14 stages or more are equipped with a pump support located near the discharge of the pump. For stability, this support should be mounted approximately 4" from the discharge.
3. Allow 8" minimum clearance behind the motor for maintenance.

Manufacturer	Motor Frame Size	Phase	Enclosure	B	C	D / D1	E	F	G	H	J	K	L
Baldor	184CZY	3	TEFC	13.80	3.88	4.50 / 5.50	7.50	8.63	4.50	8.44	7.88	6.75	4.00
Baldor	184CZY	3	ODP	12.25	3.88	4.50 / 5.50	7.50	8.63	4.50	8.44	7.88	6.75	4.00
Baldor	184CZY	1	TEFC	15.30	3.88	4.50 / 5.50	7.50	8.63	4.50	8.44	7.88	7.88	6.25
Baldor	184CZY	1	ODP	12.25	3.88	4.50 / 5.50	7.50	8.63	4.50	8.44	7.88	6.64	5.125



There when you need us most

**EZ**Series

**EZ BOOSTER DIMENSIONS**

**Cast Iron and Stainless Steel - Dimensions (Inches)**

Cast Iron Model No.	A	B*
G5B6	11.95	10.13
G5B7	12.87	10.13
G5B8	13.79	10.13
G5B10	15.62	10.13
G5B12	17.46	10.53
G5B17	22.96	10.53
G5B23	29.38	11.13
G5B28	33.97	11.63
G10B4	10.24	10.13
G10B5	11.18	10.13
G10B6	12.13	10.13
G10B8	14.03	10.53
G10B12	17.83	10.53
G10B14	19.71	11.13
G10B15	20.66	11.13
G10B18	24.45	11.63
G10B26	32.98	12.53
G15B5	11.50	10.13
G15B7	13.52	10.53
G15B9	15.54	10.53
G15B14	21.60	11.63
G15B20	27.67	12.53
G20B3	10.17	10.13
G20B4	11.42	10.13
G20B7	15.14	10.53
G20B9	17.63	11.13
G20B12	22.59	11.63
G20B15	26.32	12.53
G20B23	37.50	13.63
G35B2	9.27	10.13
G35B3	10.69	10.13
G35B5	13.51	10.53
G35B6	14.93	11.13
G35B9	19.16	11.63
G35B12	24.82	12.53
G35B16	30.47	13.63

Cast Iron Model No.	A	B*
H5B2	8.28	10.13
H5B3	9.20	10.13
H5B4	10.12	10.13
H5B5	11.03	10.13
H5B6	11.95	10.53
H5B7	12.87	10.53
H5B8	13.79	10.53
H5B10	15.62	10.53
H5B12	17.46	11.13
H5B17	22.96	11.63
H5B23	29.38	12.53
H5B28	33.97	13.63
H5B34-1	40.39	15.30
H5B41-1	46.82	15.30
H10B2	8.34	10.13
H10B3	9.29	10.13
H10B4	10.24	10.53
H10B5	11.18	10.53
H10B6	12.13	10.53
H10B8	14.03	11.13
H10B14	19.71	11.63
H10B18	24.45	12.53
H10B26-1	32.98	15.30
H10B34-1	41.50	15.30
H10B42-1	49.08	15.30

Cast Iron Model No.	A	B*
H15B2	8.47	10.13
H15B3	9.48	10.13
H15B5	11.50	10.53
H15B7	13.52	11.13
H15B9	15.54	11.63
H15B14	21.60	12.53
H15B20	27.67	13.63
H15B30-1	38.78	15.30
H15B40-1	49.90	15.30
H20B3	10.17	10.53
H20B4	11.42	10.53
H20B6	13.90	11.13
H20B7	15.14	11.63
H20B9	17.63	11.63
H20B12	22.59	12.53
H20B15	26.32	13.63
H20B23-1	37.50	15.30
H20B33-1	51.16	15.30
H35B2	9.27	10.53
H35B3	10.69	10.53
H35B5	13.51	11.63
H35B6	14.93	11.63
H35B9	19.16	13.63
H35B12	24.82	13.63
H35B16-1	30.47	15.30
H35B23-1	40.36	15.30

\*B Dimensions are estimated lengths since we reserve the right to use various brand motors.

## EZ BOOSTER REPAIR PARTS

**EZ** Series

### Cast Iron & Stainless Steel Models

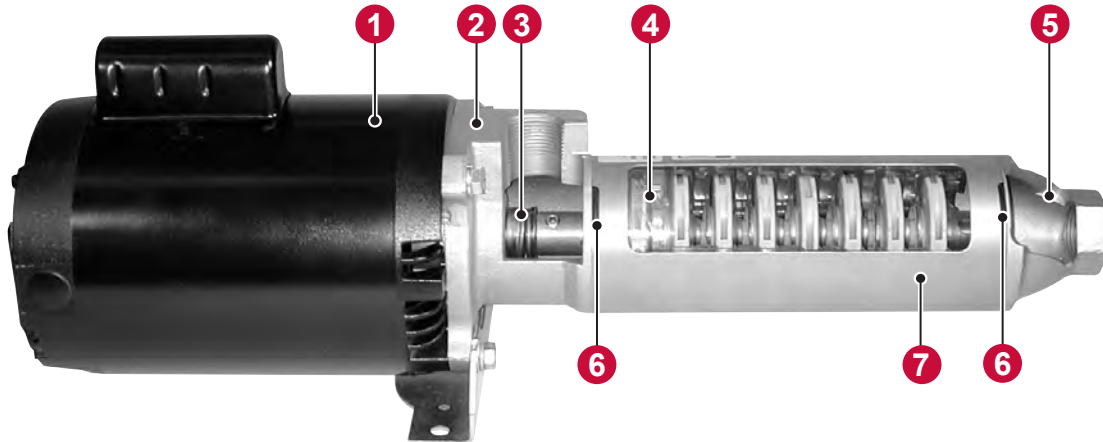

**Cast Iron**

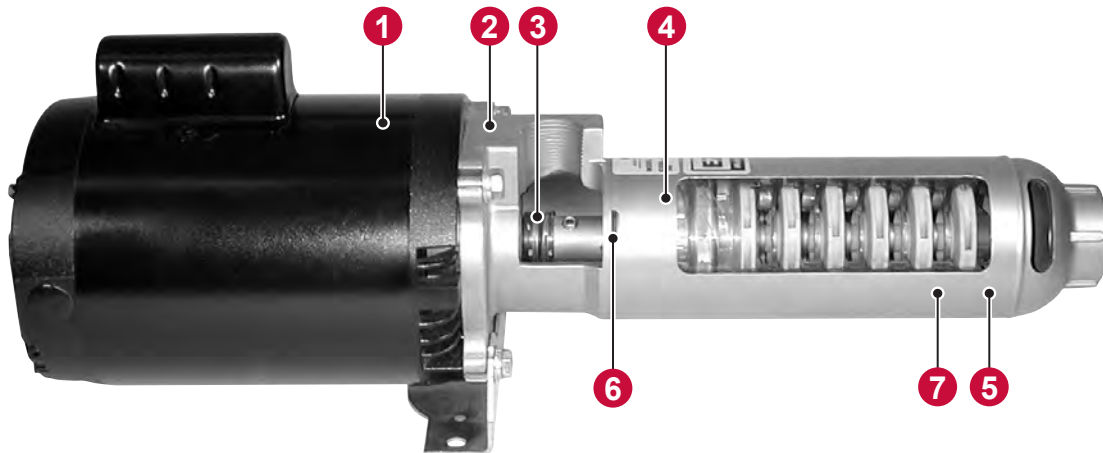

**Stainless Steel**

Webtrol manufactures many different models of EZ Series Booster Pumps. To be sure you get the right part you need, we ask that you call (314) 631-9200 and let one of our trained customer service representatives assist you.

There are 7 basic components that make up an EZ Series Booster Pump. These seven components are shown above in the display model pumps.

To order parts, note the **model number** and the **date code** of the EZ Booster pump that needs a repair part.

- |                       |             |
|-----------------------|-------------|
| 1 Motor               | 5 Discharge |
| 2 Inlet/Motor Bracket | 6 O-Rings   |
| 3 Mechanical Seal     | 7 Housing   |
| 4 Rotating Assembly   |             |



*There when you need us most*

---

## NOTES

A series of 25 horizontal lines for writing notes, spanning the width of the page.



There when you need us most

# NV SERIES VERTICAL BOOSTER PUMPS

## 304/316 Stainless Steel Booster Pumps



Space saving NV Series pumps provide you with reliable solutions for a variety of industrial, commercial, and agricultural applications.

The quality and performance you expect, along with industry best lead times and personalized service, only from Webtrol!



### Features and Benefits

- In-line, space saving design, with suction and discharge on the same plane
- Maintenance-free cartridge type mechanical seals
- All wetted parts constructed of 304 or 316 stainless steel
- Drop-in replacement for existing installations
- Standard TEFC motor enclosure
- Meets NSF/ANSI 61 and 372 standards



### Performance

HP Range: .5 - 60 HP, 60Hz.  
 Capacities to 600 GPM  
 Pressures to 380 PSI  
 Temperatures to 248 °F

### Typical Services

- Water Supply
- Reverse Osmosis
- Water Boosting
- Washing Systems
- Jockey Pump
- Water Treatment
- Filtration
- Plants
- Boiler Feed
- Hot & Cold Water
- Circulation
- Irrigation
- Sprinkler Systems
- Heat Exchangers

## BOOSTER PUMPS

### Construction & Design Features

Series	Stages	Max. Working Pressure	Stages	Max. Inlet Pressure
NV6	2 - 27	362	2 - 26	150
		362	27	220
NV12	2 - 25	362	2 - 15	150
			17 - 25	220
NV25	2 - 24	362	2 - 9	150
			10 - 24	220
NV45	1 - 10	232	1 - 5	118
	12 - 17	362	6 - 18	150
NV65	1 - 8	232	1 - 2	118
	9 - 12	362	3 - 12	150
NV85	1 - 7	232	1	118
	8 - 10	362	2 - 10	150
NV120	1 - 5	232	1 - 2	59
	6 - 10	465	3 - 6	150
			7 - 10	220
NV180	1 - 4	232	1	59
	5 - 7	465	2 - 3	150
			4 - 7	220
NV280	1 - 3	232	(1 - 1)	59
	4 - 5	465	1 - (2 - 1)	150
			2 - 5	220
NV400	1 - 3	232	1 - (2 - 2)	150
	4	465	(2 - 1) - 4	220

MODEL NO.: **NV25B9FE3T**

Series/Nominal Rated Flow (GPM)

Construction  
B = 304SS S = 316SS

Number of Stages

Connection  
F = Flanged V = Victaulic

Elastomers  
E = EPDM V = Viton

Phase / Hz (PH)  
1 = 1PH / 60Hz 3 = 3PH / 60Hz

Motor Enclosure  
D = ODP T = TEFC



Component	304 SS Models		316 SS Models	
	NV6B thru NV85B	NV120B thru NV400B	NV6S thru NV85S	NV120S thru NV400S
Motor Bracket	Cast Iron	Cast Iron	Cast Iron	Cast Iron
Pump Head	304 SS	304 SS	316 SS	316 SS
Impeller	304 SS	304 SS	316 SS	316 SS
Diffuser	304 SS	304 SS	316 SS	316 SS
Neck Ring	Teflon	Carbon Reinforced Teflon	Teflon	Carbon Reinforced Teflon
Shaft	431 SS	431 SS	316 SS	316 SS
Casing	304 SS	304 SS	316 SS	316 SS
O-Ring	EPDM	EPDM	EPDM	EPDM
Pump Base	304 SS	304 SS	316 SS	316 SS
Base Plate	Cast Iron	Cast Iron	Cast Iron	Cast Iron
Mech Seal	Silicon Carbide/Silicon Carbide/EPDM			



## SERIES FAMILY CURVES

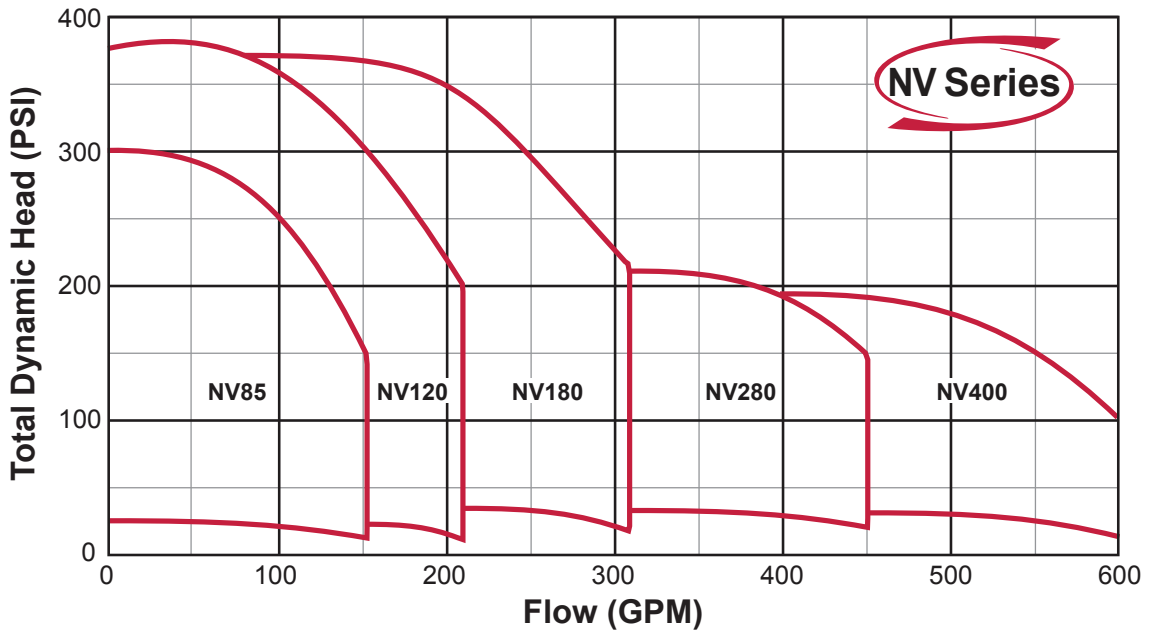
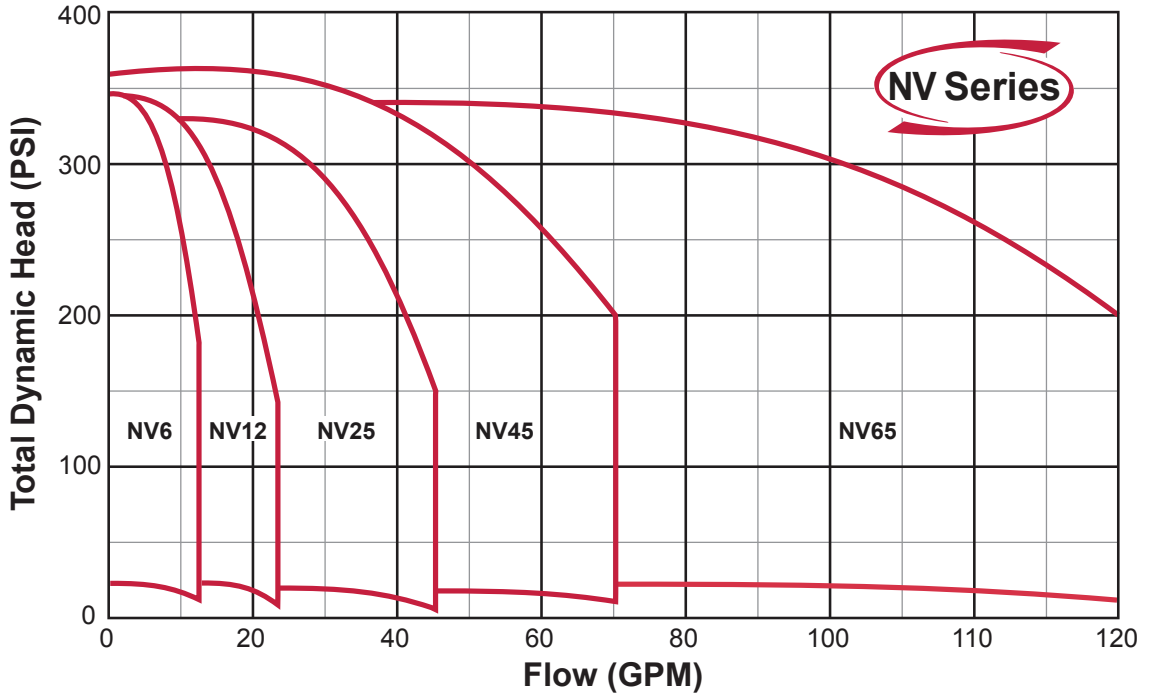

Note:  
 NV Series curves in this catalog are based on 60 Hz 3450 rpm motors. 50 Hz 2875 rpm curves are available. These curves are for general guidance only, individual pump curves are available upon request. A certified curve may be requested for an additional cost. Webtrol will build pumps to fit your specific needs, contact factory for pricing.

### NV6 PUMP DIMENSIONS

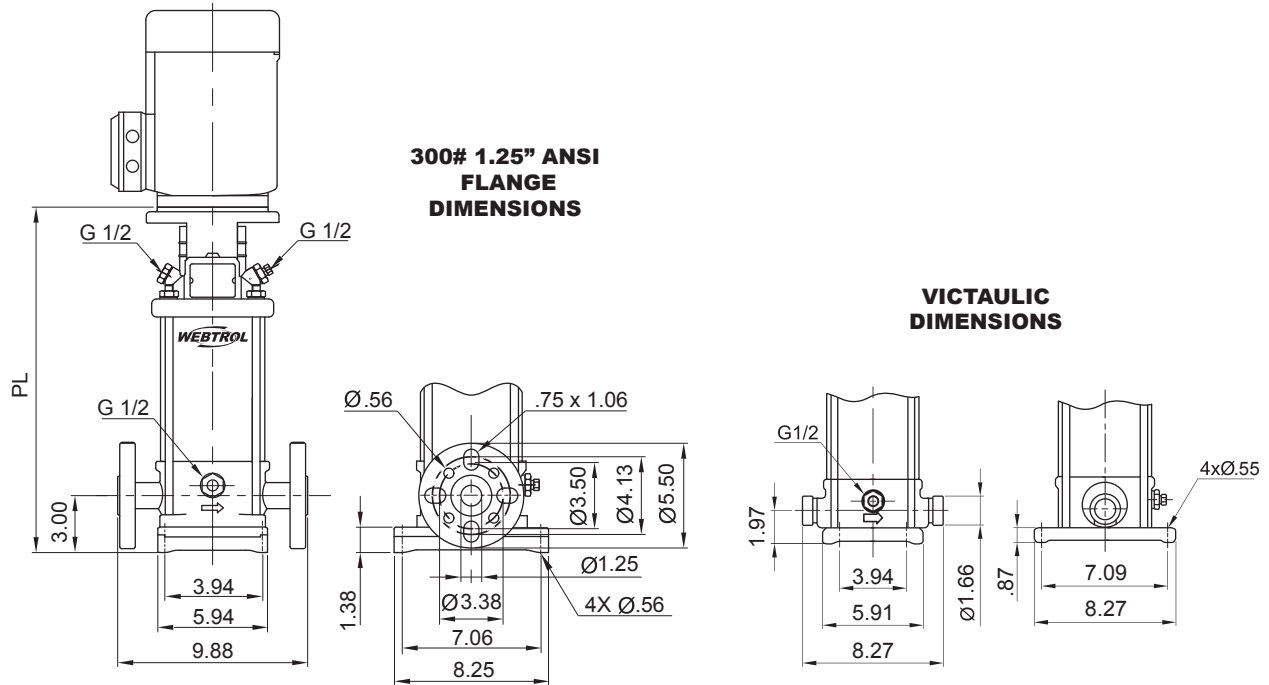

**NOTES:** All dimensions are in inches unless otherwise noted. Please contact factory for specific motor manufacturer dimensions

Model	HP	Motor Frame	Pump Length (PL) - in. Flange	Pump Length (PL) - in. Victaulic	Pump End Weight - lbs. Flange	Pump End Weight - lbs. Victaulic
NV6B2	.5	56C	12.05	11.06	33	31
NV6B3	.5	56C	12.05	11.06	34	32
NV6B4	.5	56C	12.76	11.77	34	32
NV6B5	.5	56C	13.46	12.48	35	33
NV6B6	.75	56C	14.17	13.19	36	34
NV6B7	.75	56C	14.84	13.86	37	35
NV6B8	1	56C	15.55	14.57	37	35
NV6B9	1	56C	16.26	15.28	38	36
NV6B10	1	56C	16.97	15.98	39	37
NV6B11	1.5	56C	17.68	16.69	40	38
NV6B12	1.5	56C	18.39	17.40	41	39
NV6B13	1.5	56C	19.09	18.11	42	39
NV6B15	2	56C	20.55	19.57	44	42
NV6B17	2	56C	21.97	20.98	45	43
NV6B19	2	56C	23.39	23.33	52	50
NV6B21	3	182TC	25.73	24.74	54	52
NV6B23	3	182TC	27.15	26.16	55	53
NV6B25	3	182TC	28.56	27.58	57	55
NV6B27	3	182TC	29.98	29.00	58	56



There when you need us most

## NV6 SERIES GROUP CURVES

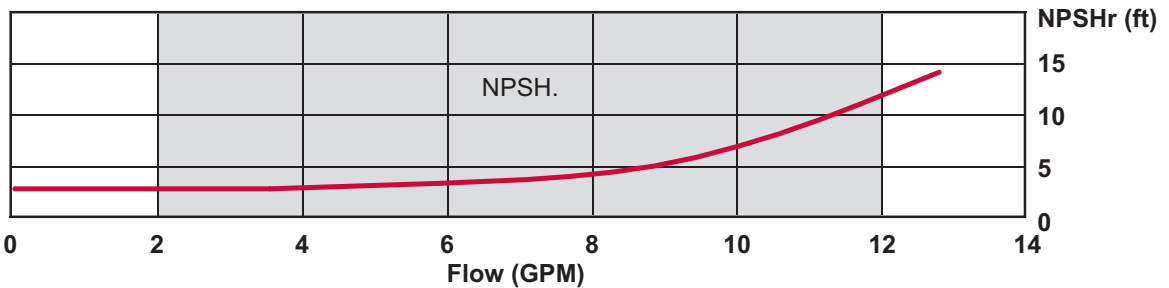
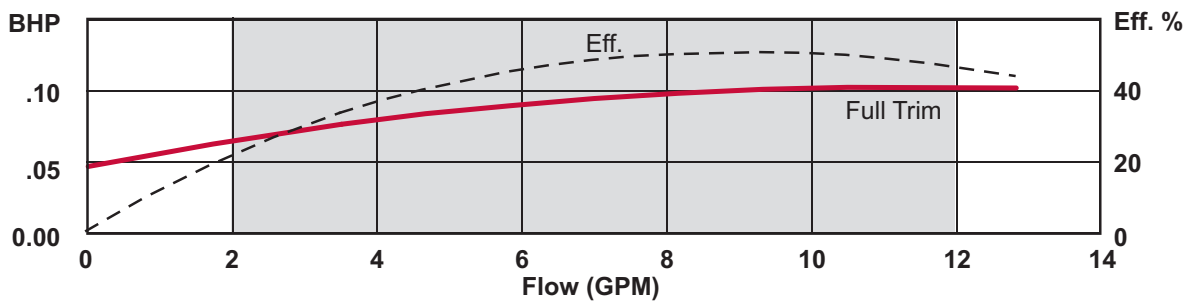
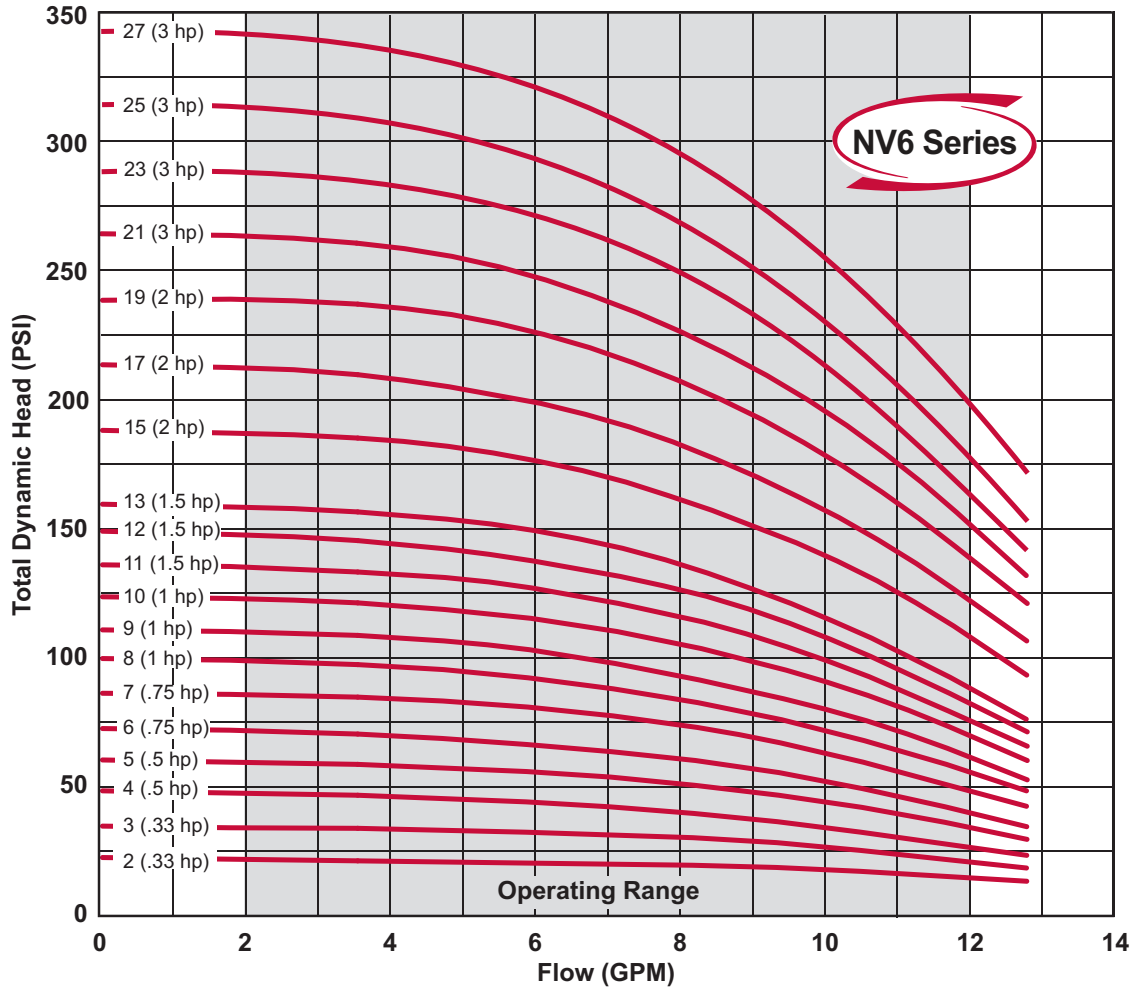

### NV12 PUMP DIMENSIONS

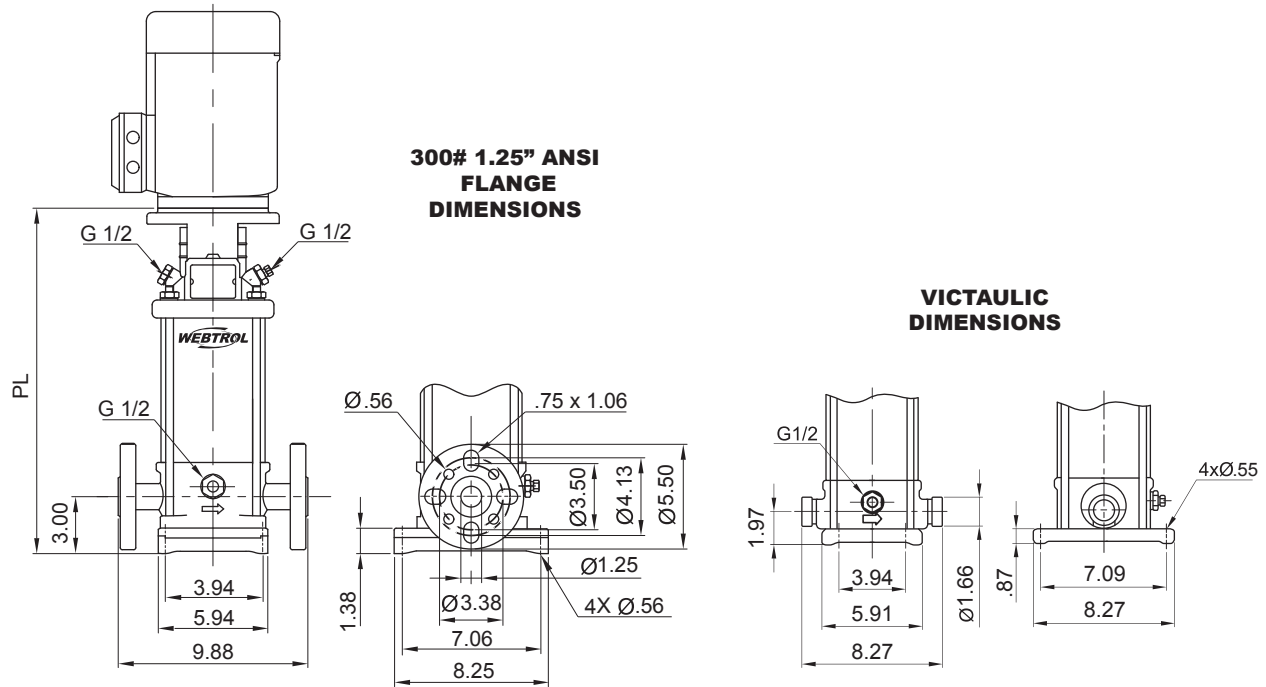

**NOTES:** All dimensions are in inches unless otherwise noted. Please contact factory for specific motor manufacturer dimensions.

Model	HP	Motor Frame	Pump Length (PL) - in. Flange	Pump Length (PL) - in. Victaulic	Pump End Weight - lbs. Flange	Pump End Weight - lbs. Victaulic
NV12B2	.5	56C	12.05	11.06	33	31
NV12B3	.5	56C	12.05	11.06	34	32
NV12B4	.75	56C	12.76	11.77	34	32
NV12B5	.75	56C	13.43	12.44	35	33
NV12B6	1	56C	14.13	13.15	36	34
NV12B7	1.5	56C	14.84	13.86	37	35
NV12B8	1.5	56C	15.55	14.57	37	35
NV12B9	1.5	56C	16.30	15.31	38	36
NV12B10	2	56C	17.01	16.02	40	38
NV12B11	2	56C	17.72	16.73	41	39
NV12B12	2	56C	18.43	17.44	42	39
NV12B13	3	182TC	20.06	19.07	47	45
NV12B15	3	182TC	21.48	20.49	49	47
NV12B17	3	182TC	22.89	21.91	51	49
NV12B19	3	182TC	24.50	23.33	52	50
NV12B21	5	182TC	25.73	24.74	54	52
NV12B23	5	182TC	27.15	26.16	55	53
NV12B25	5	182TC	28.56	27.58	57	55



There when you need us most

## NV12 SERIES GROUP CURVES

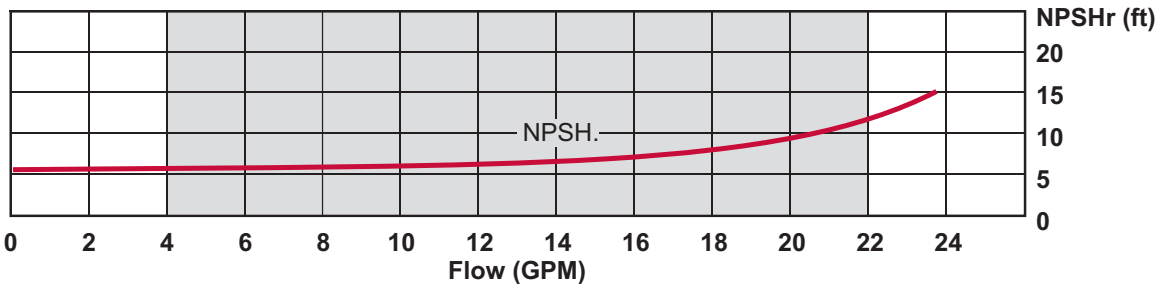
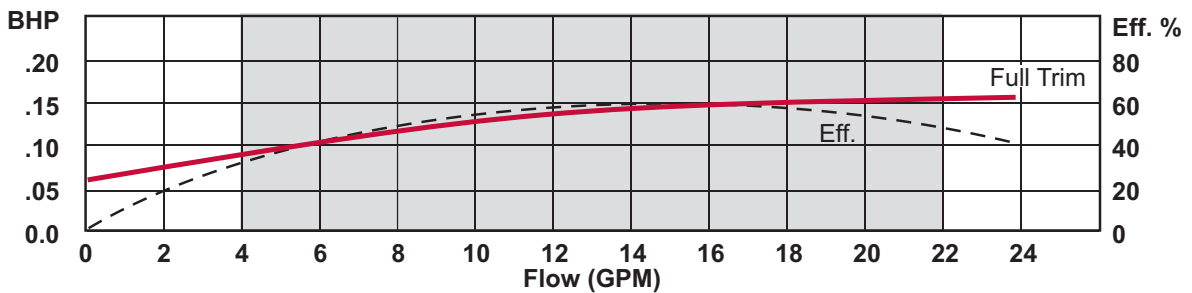
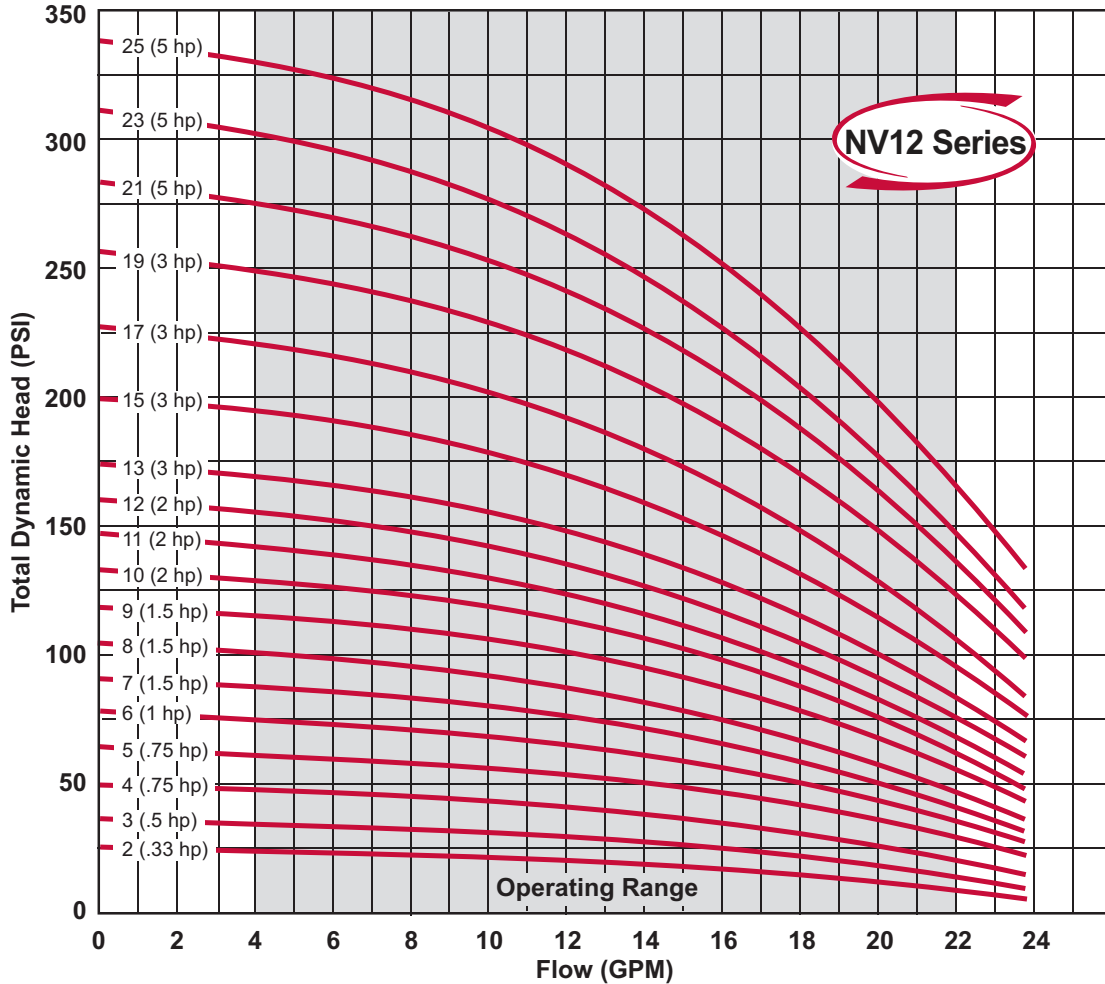

### NV25 PUMP DIMENSIONS

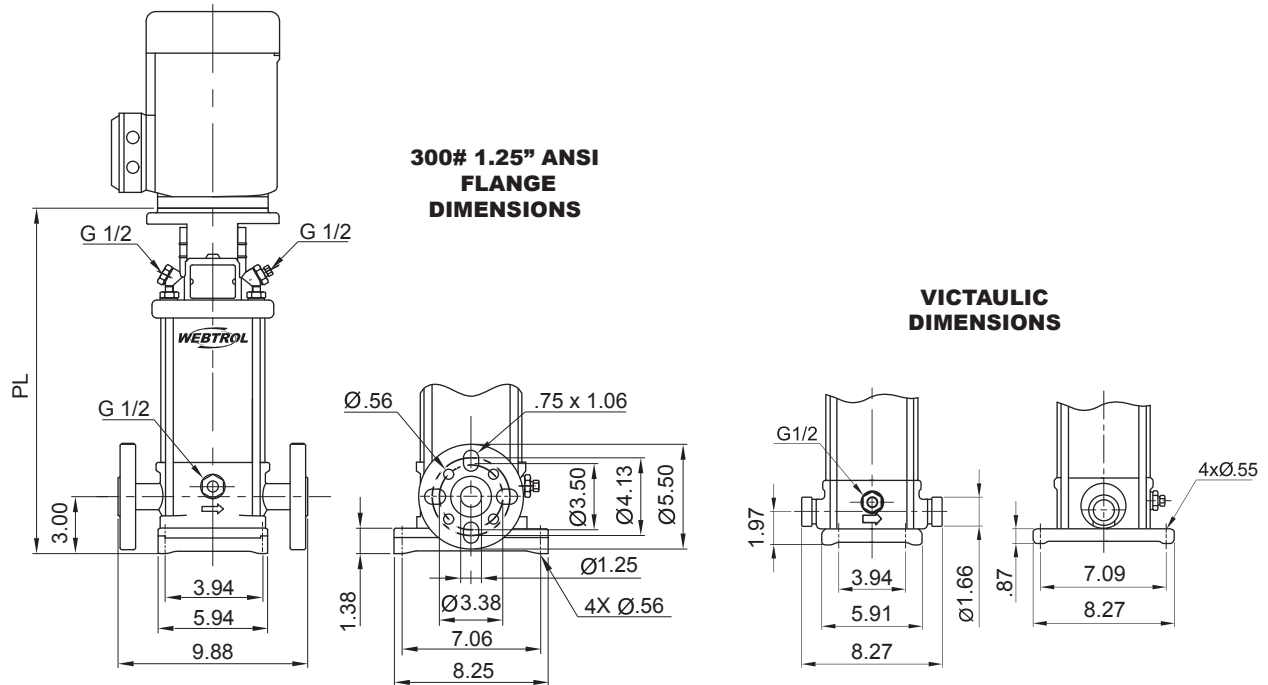

**NOTES:** All dimensions are in inches unless otherwise noted. Please contact factory for specific motor manufacturer dimensions

Model	HP	Motor Frame	Pump Length (PL) - in. Flange	Pump Length (PL) - in. Victaulic	Pump End Weight - lbs. Flange	Pump End Weight - lbs. Victaulic
NV25B2	.75	56C	11.93	11.06	33	31
NV25B3	1	56C	13.10	12.09	35	33
NV25B4	1.5	56C	14.06	13.15	36	34
NV25B5	1.5	56C	15.12	14.25	38	36
NV25B6	2	56C	16.28	15.31	39	37
NV25B7	2	56C	17.40	17.30	45	43
NV25B8	3	182TC	19.35	18.37	46	44
NV25B9	3	182TC	20.31	19.43	47	45
NV25B10	3	182TC	21.44	20.50	49	46
NV25B11	5	182TC	22.50	21.56	50	48
NV25B12	5	182TC	23.56	22.62	51	49
NV25B13	5	182TC	24.63	23.68	52	50
NV25B14	5	182TC	25.69	24.74	53	51
NV25B15	5	182TC	26.75	25.81	54	52
NV25B16	5	182TC	27.82	26.88	56	53
NV25B18	7.5	213TC	30.57	29.59	63	61
NV25B20	7.5	213TC	32.70	31.71	66	64
NV25B22	7.5	213TC	34.72	33.84	68	66
NV25B24	7.5	213TC	36.85	35.96	70	68



There when you need us most

## NV25 SERIES GROUP CURVES

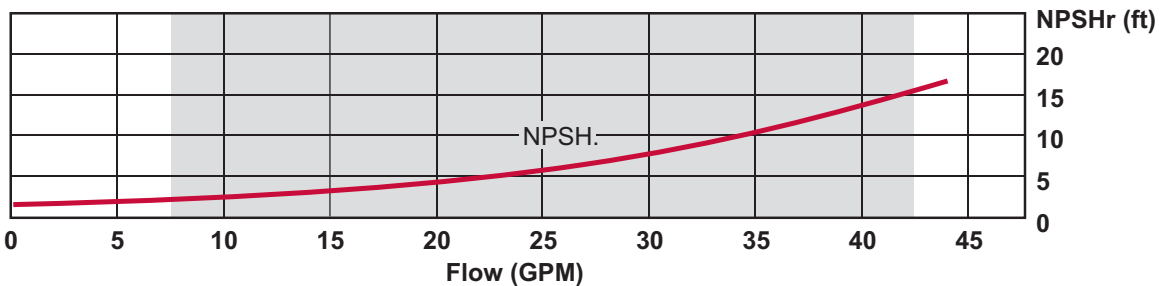
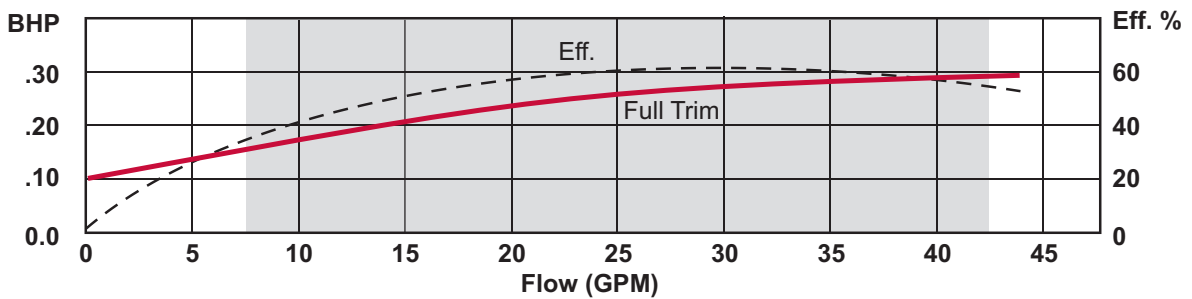
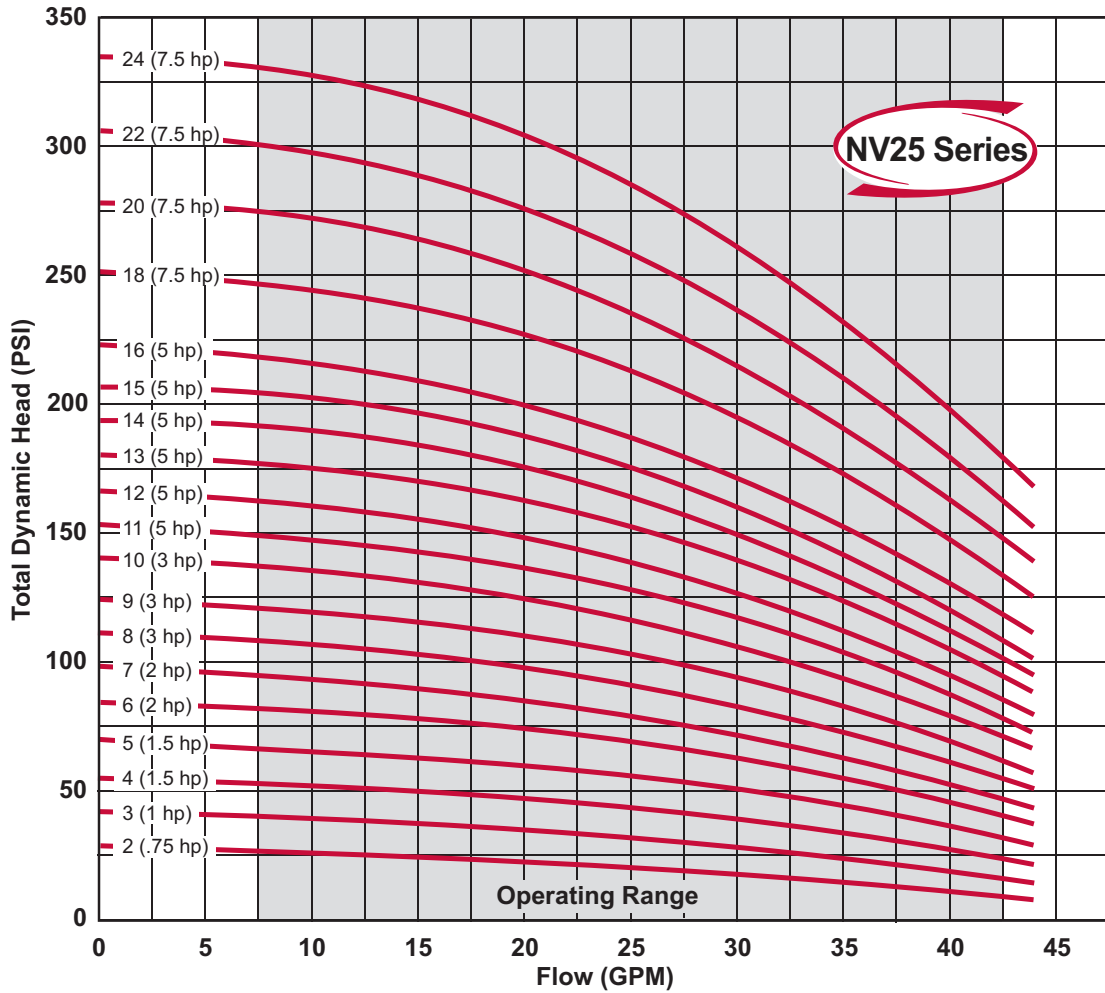

## NV45 PUMP DIMENSIONS

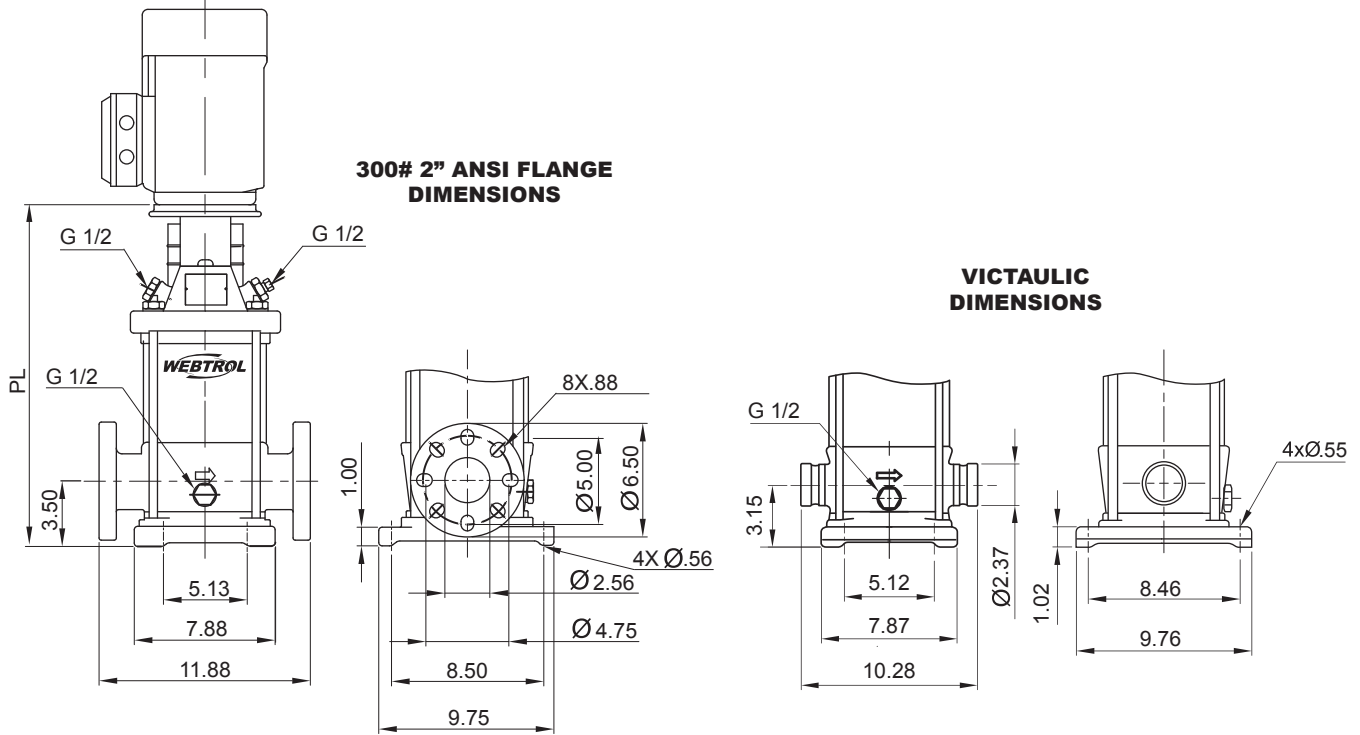

**NOTES:** All dimensions are in inches unless otherwise noted. Please contact factory for specific motor manufacturer dimensions.

Model	HP	Motor Frame	Pump Length (PL) - in. Flange	Pump Length (PL) - in. Victaulic	Pump End Weight - lbs. Flange	Pump End Weight - lbs. Victaulic
NV45B1	1	56C	14.96	14.53	60	58
NV45B2	1.5	56C	14.96	14.53	60	59
NV45B3	3	182TC	17.15	16.71	84	83
NV45B4	3	182TC	18.35	17.91	87	85
NV45B5	5	182TC	19.53	19.09	89	87
NV45B6	5	182TC	20.71	20.28	91	89
NV45B7	5	182TC	21.25	22.00	97	96
NV45B8	7.5	213TC	23.62	23.19	99	98
NV45B9	7.5	213TC	24.80	24.37	101	100
NV45B10	7.5	213TC	25.98	25.55	104	102
NV45B12	10	213TC	28.34	27.91	108	107
NV45B14	10	213TC	30.01	32.90	126	125
NV45B16	15	254TC	35.69	35.26	130	129
NV45B17	15	254TC	36.89	37.62	133	132





There when you need us most

## NV45 SERIES GROUP CURVES

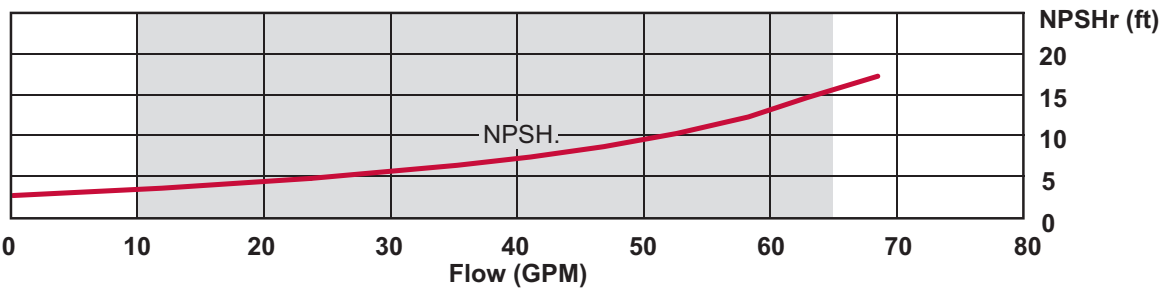
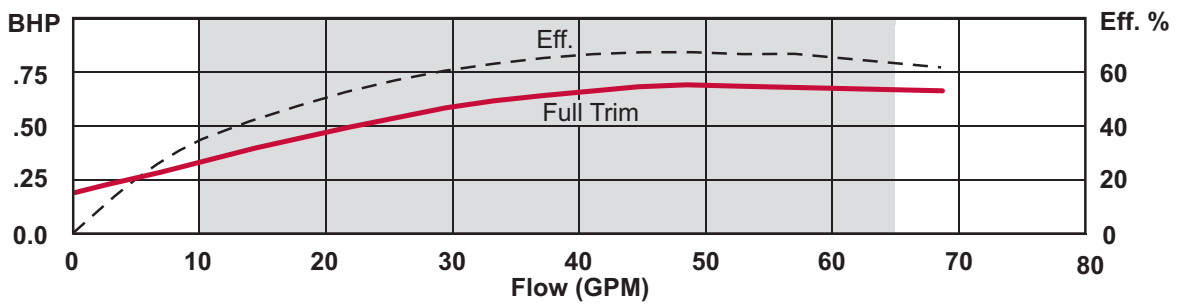
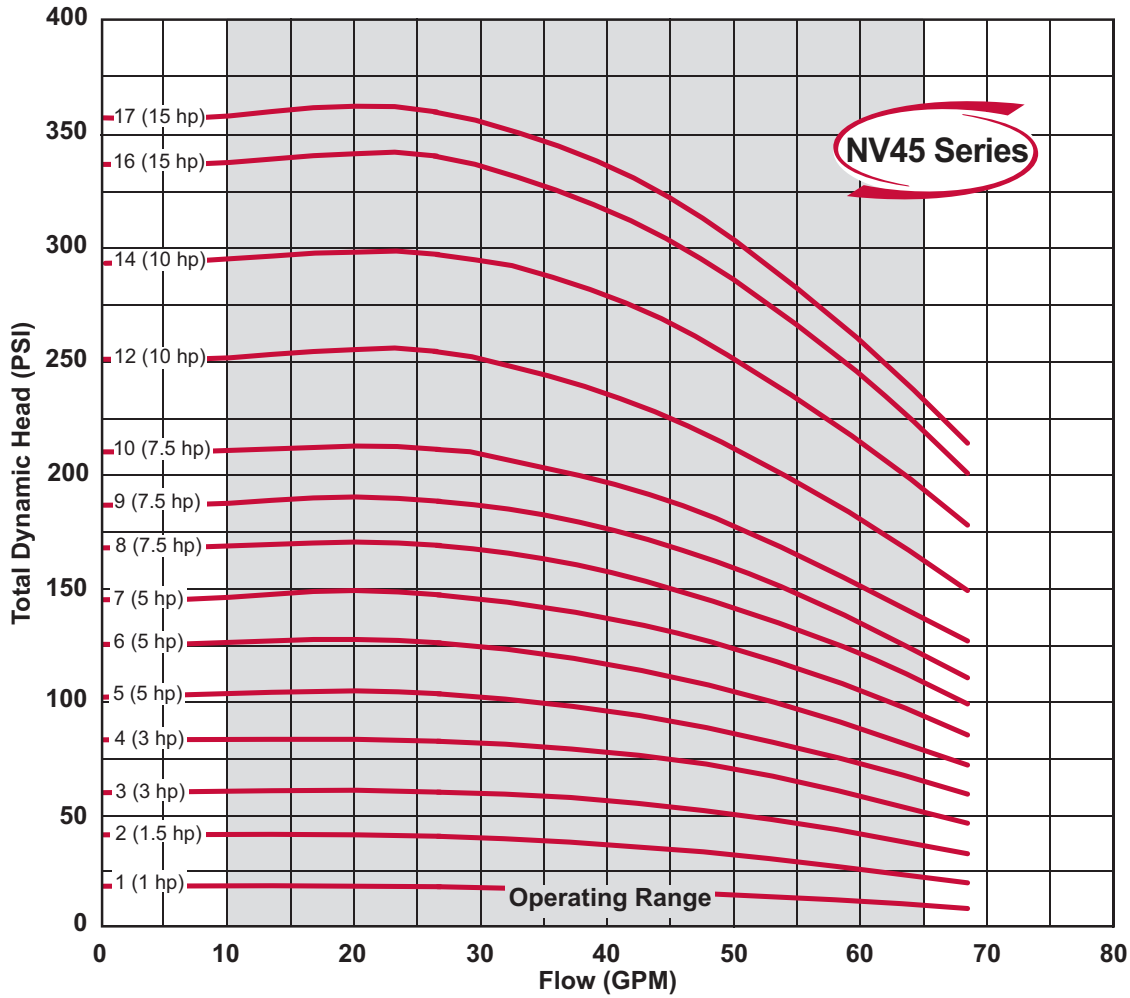

### NV65 PUMP DIMENSIONS

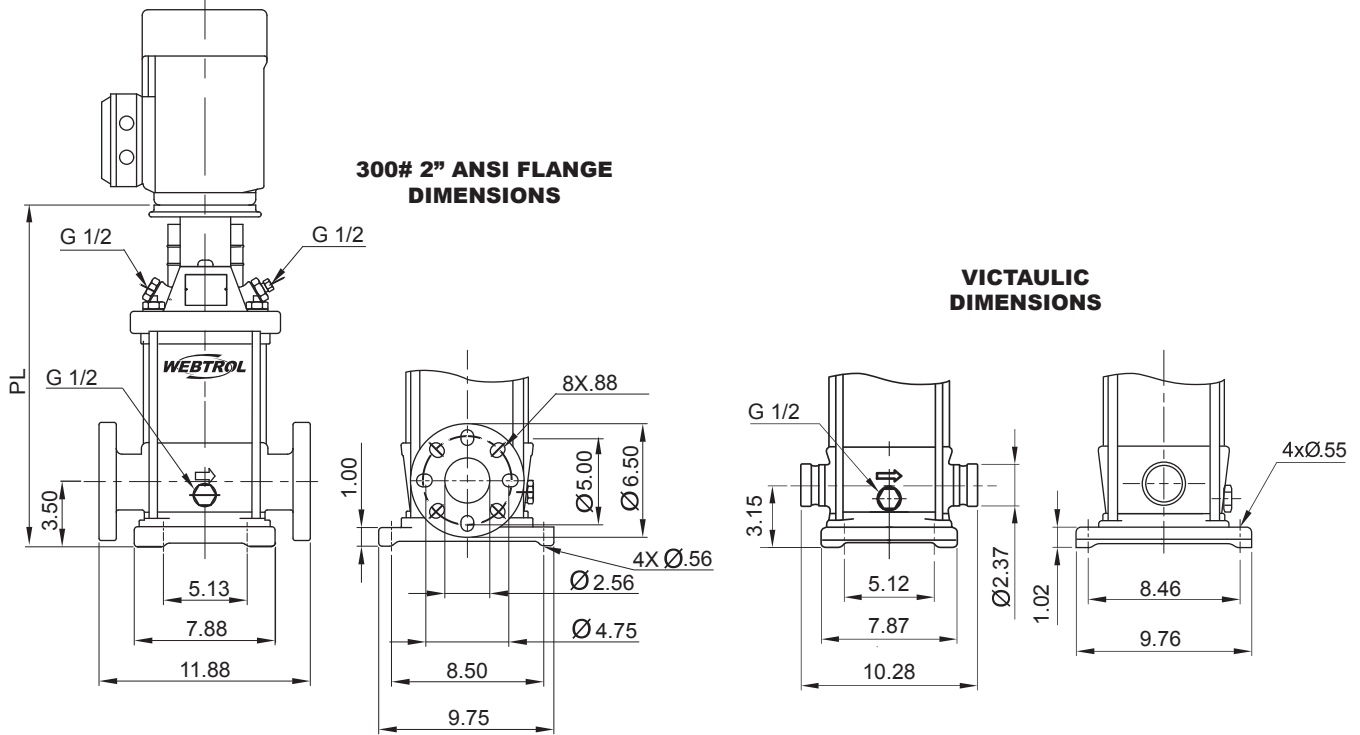

**NOTES:** All dimensions are in inches unless otherwise noted. Please contact factory for specific motor manufacturer dimensions.

Model	HP	Motor Frame	Pump Length (PL) - in. Flange	Pump Length (PL) - in. Victaulic	Pump End Weight - lbs. Flange	Pump End Weight - lbs. Victaulic
NV65B1	2	56C	16.10	15.71	62	61
NV65B2	5	182TC	17.13	16.73	84	82
NV65B3	5	182TC	18.30	19.09	91	89
NV65B4	7.5	213TC	21.22	20.82	94	92
NV65B5	10	213TC	22.99	22.59	97	96
NV65B6	10	213TC	24.07	26.99	114	112
NV65B7	15	254TC	29.16	28.76	117	115
NV65B8	15	254TC	30.93	30.54	120	118
NV65B9	15	254TC	32.70	32.31	123	121
NV65B10	20	254TC	34.47	34.08	126	125
NV65B12	25	284TSC	37.26	36.87	126	125



There when you need us most

## NV65 SERIES GROUP CURVES

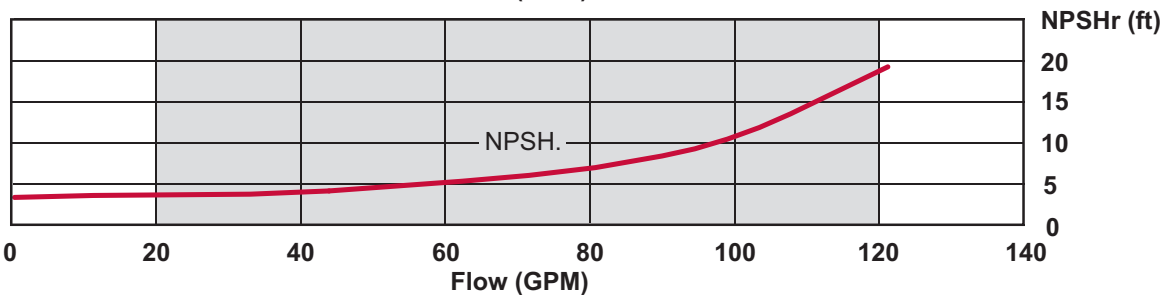
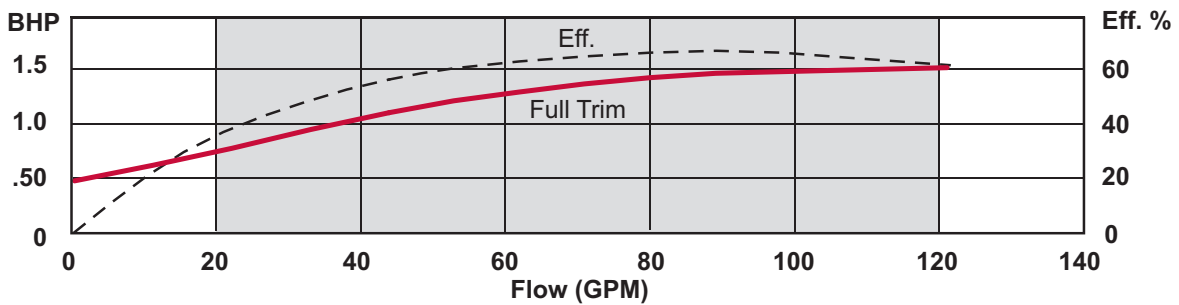
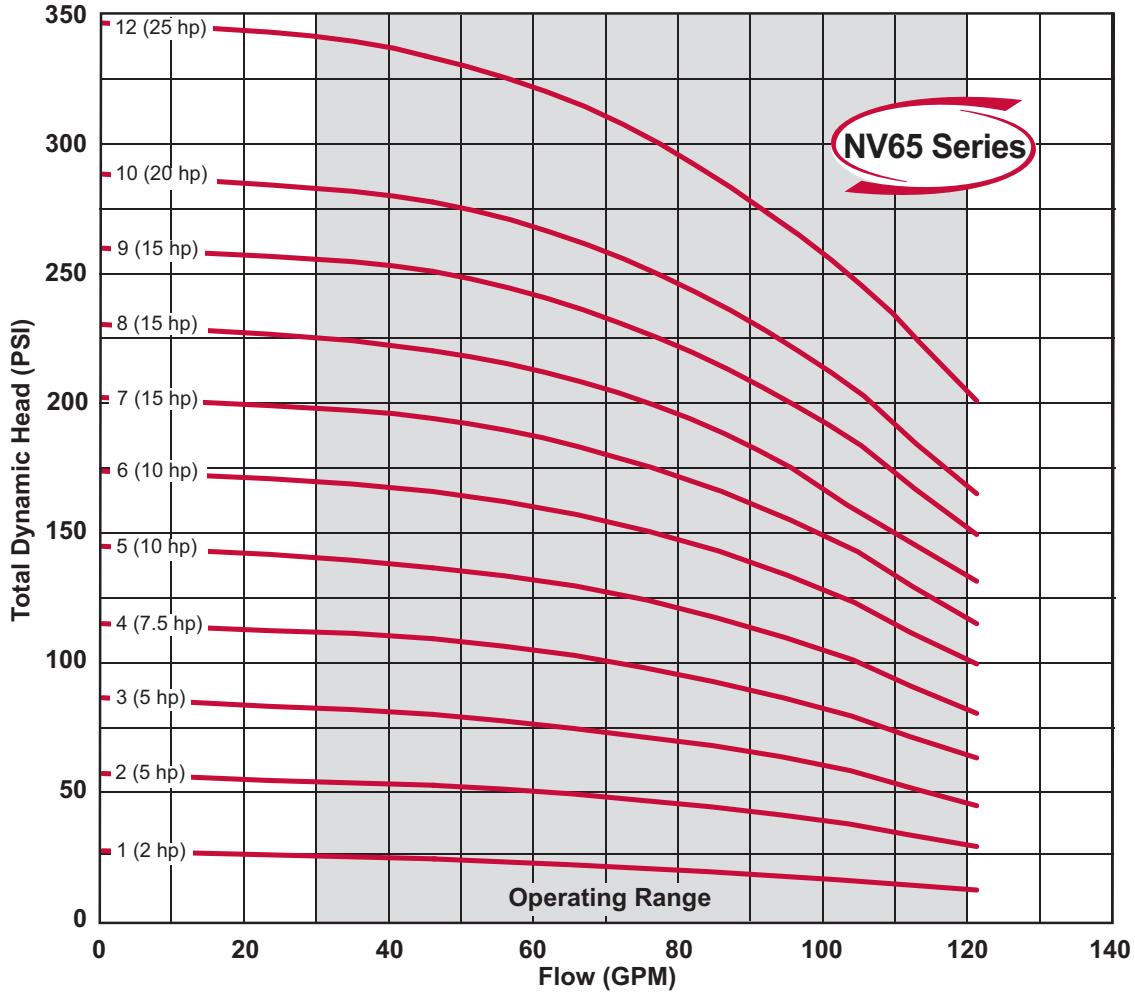

### NV85 PUMP DIMENSIONS

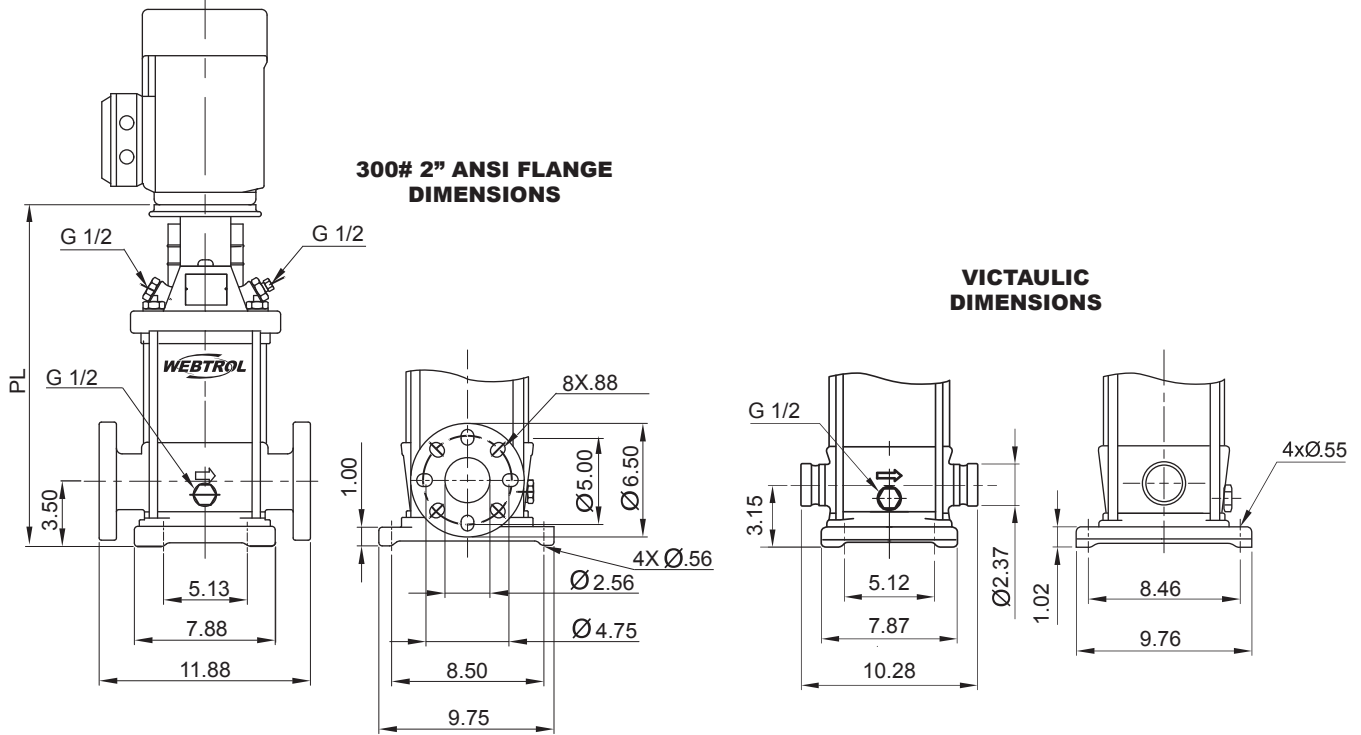

**NOTES:** All dimensions are in inches unless otherwise noted. Please contact factory for specific motor manufacturer dimensions.

Model	HP	Motor Frame	Pump Length (PL) - in. Flange	Pump Length (PL) - in. Victaulic	Pump End Weight - lbs. Flange	Pump End Weight - lbs. Victaulic
NV85B1	3	182TC	17.19	16.79	89	87
NV85B2	5	182TC	17.20	16.81	92	90
NV85B3	7.5	213TC	19.52	19.13	102	100
NV85B4	10	213TC	21.30	20.90	105	103
NV85B5	15	254TC	25.69	25.30	118	116
NV85B6	15	254TC	27.46	27.07	121	119
NV85B7	20	254TC	29.24	28.84	124	122
NV85B8	20	254TC	31.01	30.61	127	125
NV85B10	25	284TSC	33.80	33.41	135	133



There when you need us most

## NV85 SERIES GROUP CURVES

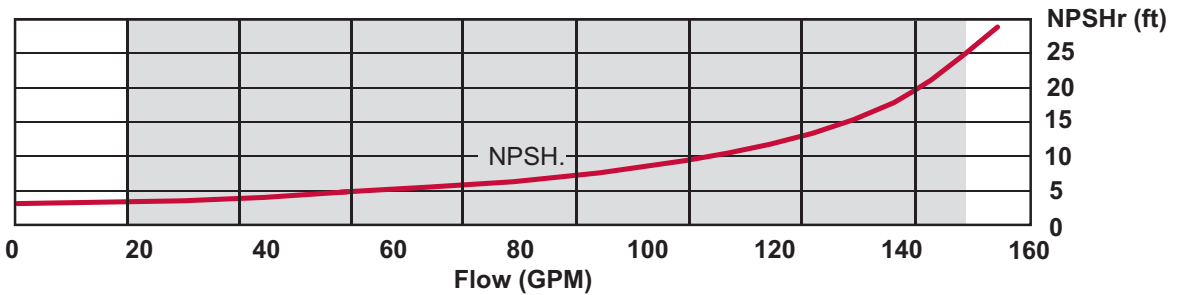
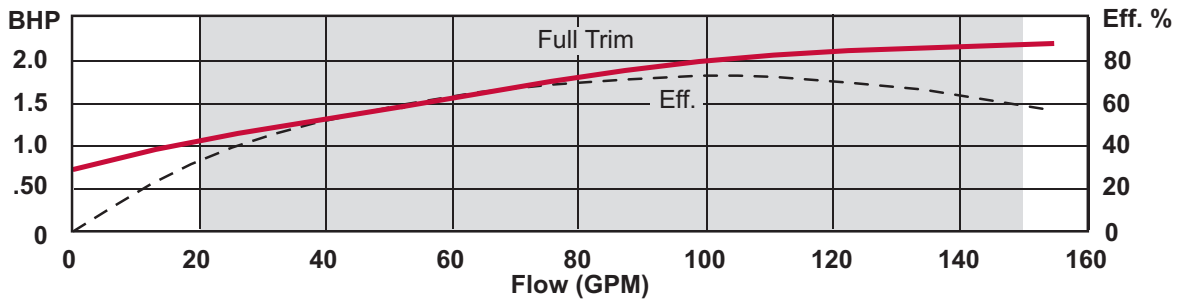
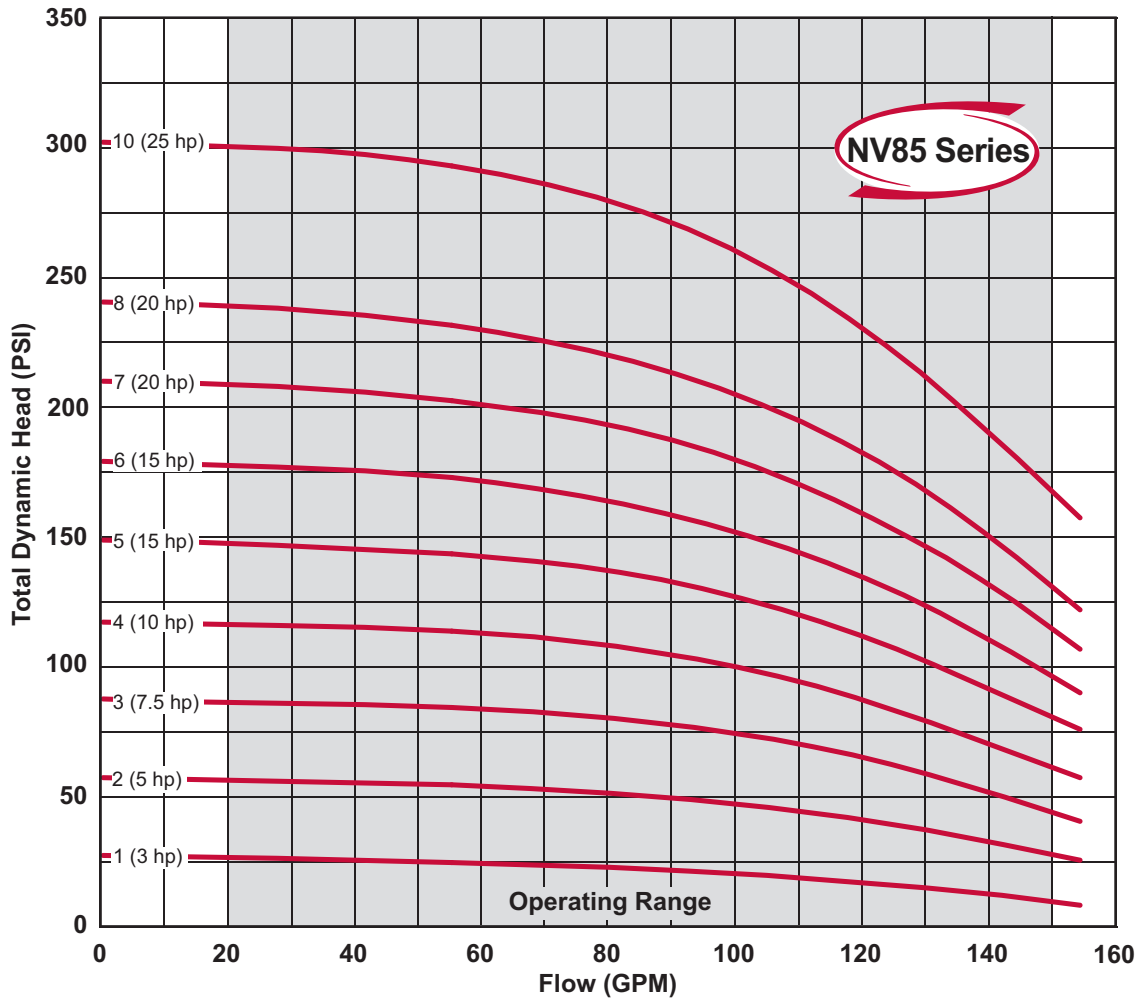

### NV120 PUMP DIMENSIONS

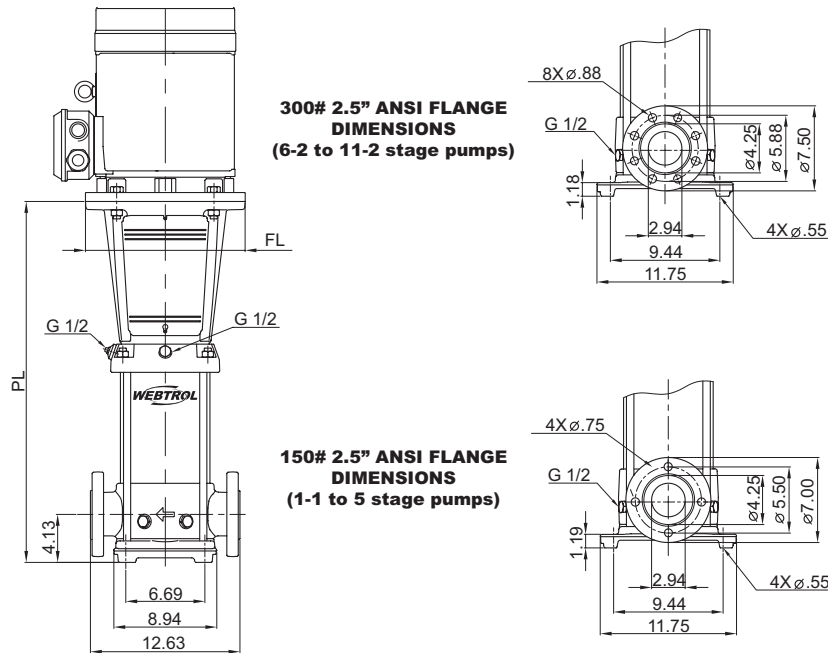

**NOTES:** All dimensions are in inches unless otherwise noted. Please contact factory for specific motor manufacturer dimensions

Model	HP	Motor Frame	Pump Length (PL) - in. Flange	Pump End Weight - lbs.
NV120B1-1	3	182TC	20.02	110
NV120B1	5	182TC	20.02	110
NV120B2-2	7.5	213TC	22.78	117
NV120B2-1	7.5	213TC	22.78	117
NV120B2	7.5	213TC	22.78	117
NV120B3-2	10	213TC	25.53	124
NV120B3	15	254TC	29.67	145
NV120B4-2	15	254TC	32.42	151
NV120B4	15	254TC	32.42	151
NV120B5-2	20	254TC	35.18	158
NV120B5	20	254TC	35.18	158
NV120B6-2	25	284TSC	37.93	167
NV120B6	25	284TSC	37.93	167
NV120B7-2	30	286TSC	40.69	174
NV120B7	30	286TSC	40.69	174
NV120B8-2	30	286TSC	43.44	181
NV120B8	40	286TSC	43.44	181
NV120B9-2	40	286TSC	46.20	186
NV120B9	40	286TSC	46.20	187
NV120B10-2	40	286TSC	48.96	192
NV120B10	40	286TSC	48.96	192
NV120B11-2	40	286TSC	51.71	198



There when you need us most

# NV120 SERIES GROUP CURVES

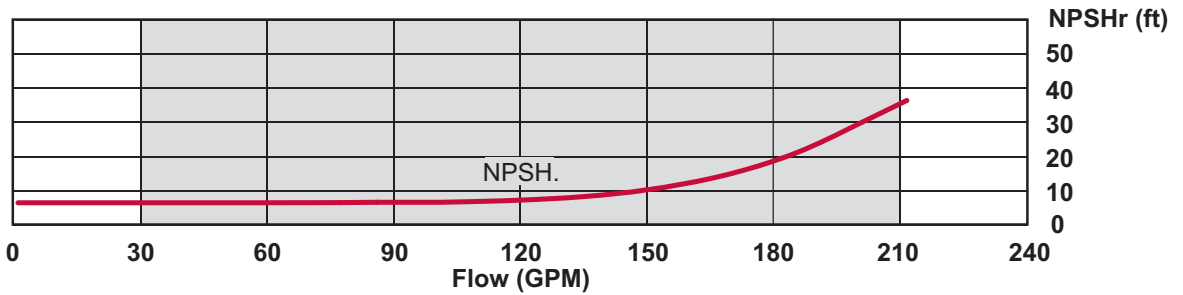
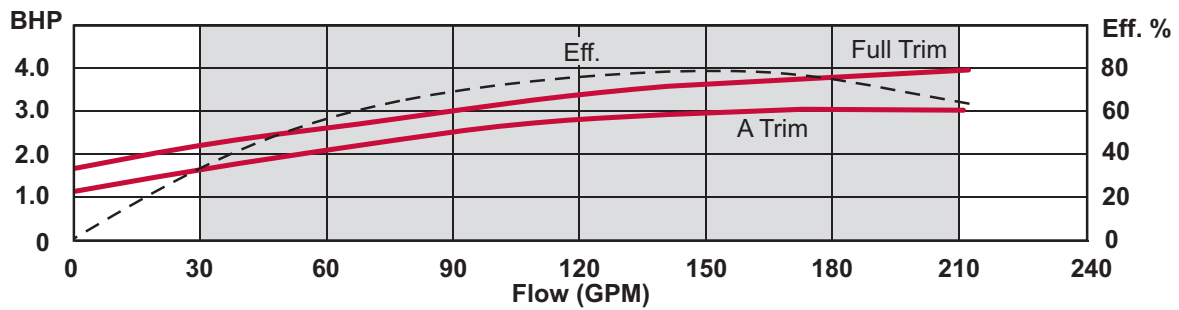
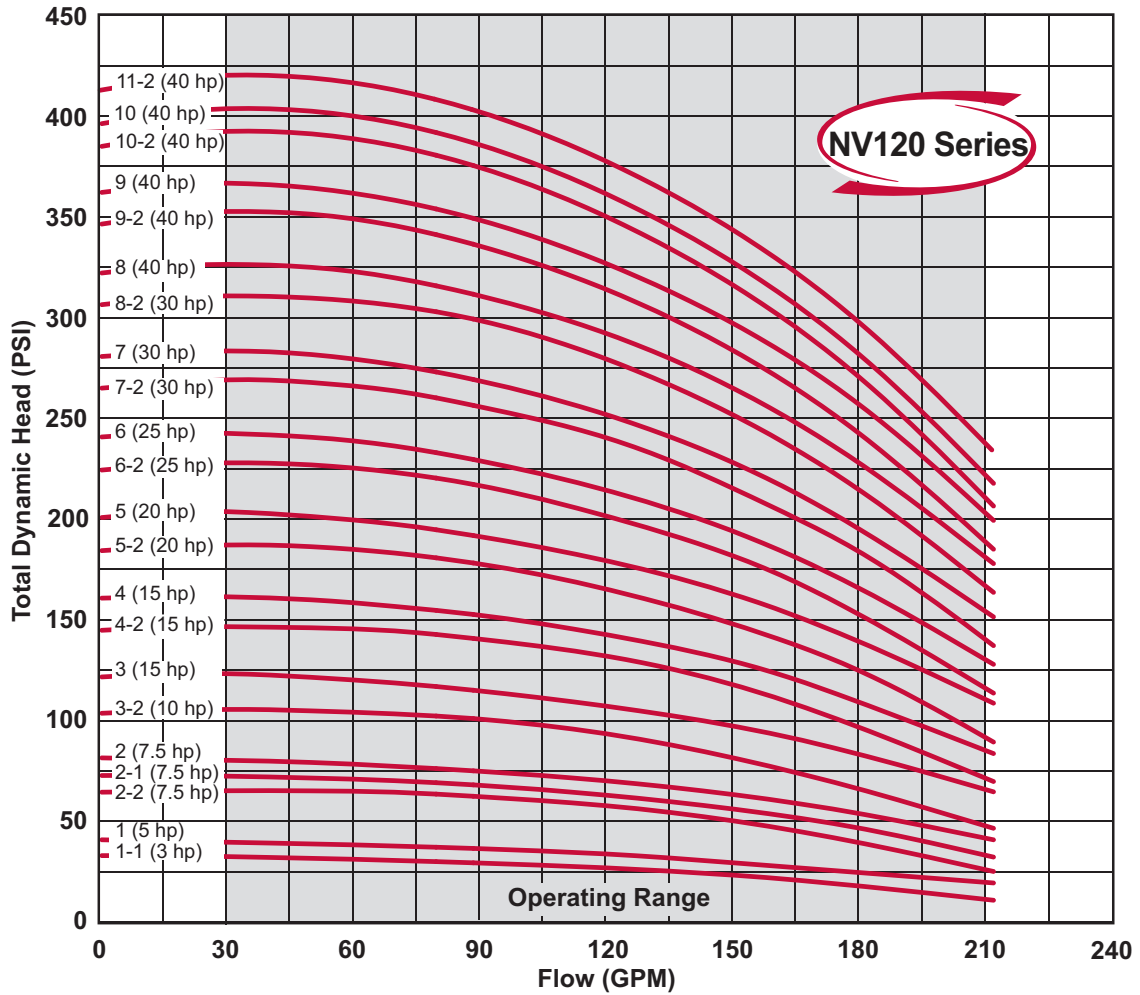

### NV180 PUMP DIMENSIONS

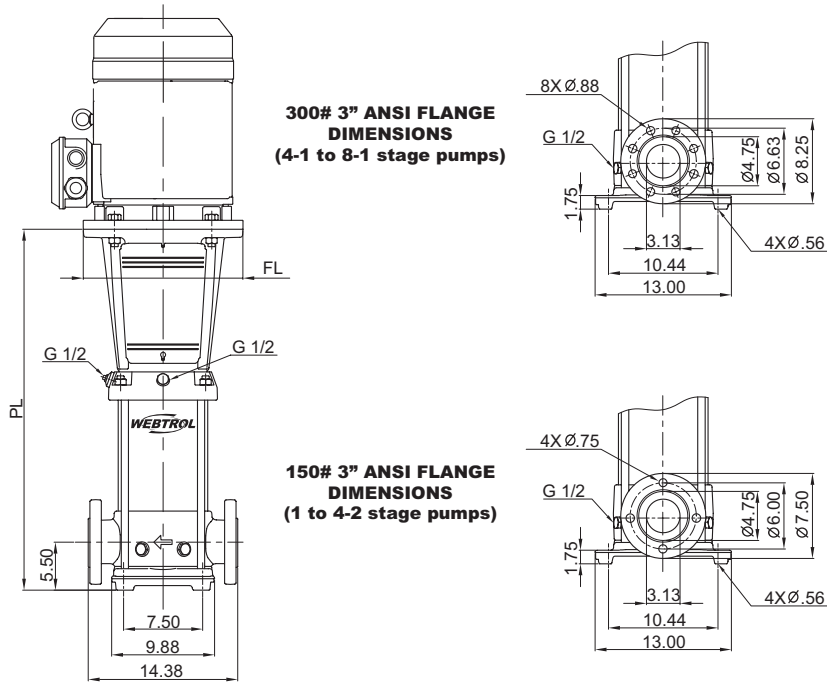

**NOTES:** All dimensions are in inches unless otherwise noted. Please contact factory for specific motor manufacturer dimensions

Model	HP	Motor Frame	Pump Length (PL) - in. Flange	Pump End Weight - lbs.
NV180B1-1	7.5	213TC	22.20	125
NV180B1	7.5	213TC	22.20	125
NV180B2-2	15	254TC	29.49	154
NV180B2-1	15	254TC	29.49	154
NV180B2	15	254TC	29.49	154
NV180B3-2	20	254TC	32.64	162
NV180B3-1	25	284TSC	32.64	165
NV180B3	25	284TSC	32.64	165
NV180B4-2	30	286TSC	35.79	173
NV180B4-1	30	286TSC	35.79	173
NV180B4	30	286TSC	35.79	173
NV180B5-2	40	286TSC	38.94	181
NV180B5-1	40	286TSC	38.94	181
NV180B5	40	286TSC	38.94	181
NV180B6-2	50	326TSC	42.09	206
NV180B6-1	50	326TSC	42.09	206
NV180B6	50	326TSC	42.09	206
NV180B7-2	50	326TSC	45.24	214
NV180B7-1	60	364TSC	45.24	214
NV180B7	60	364TSC	45.24	214
NV180B8-1	60	364TSC	48.39	221





There when you need us most

# NV180 SERIES GROUP CURVES

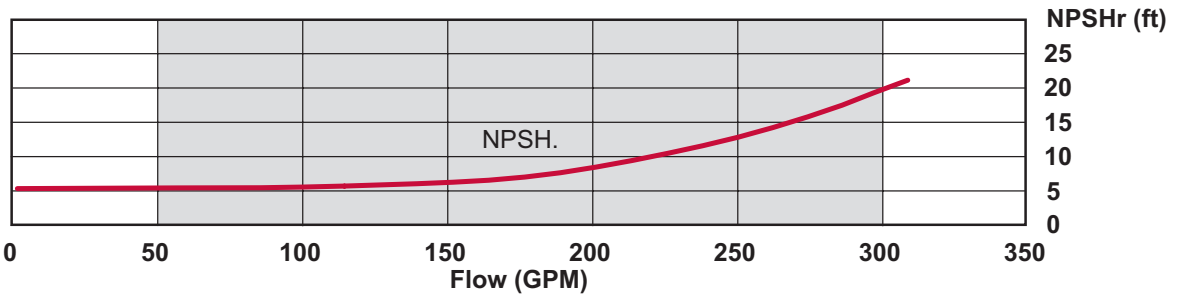
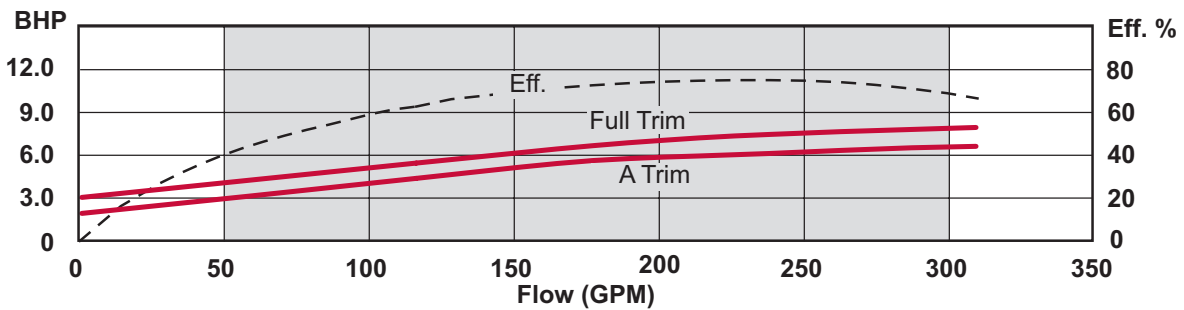
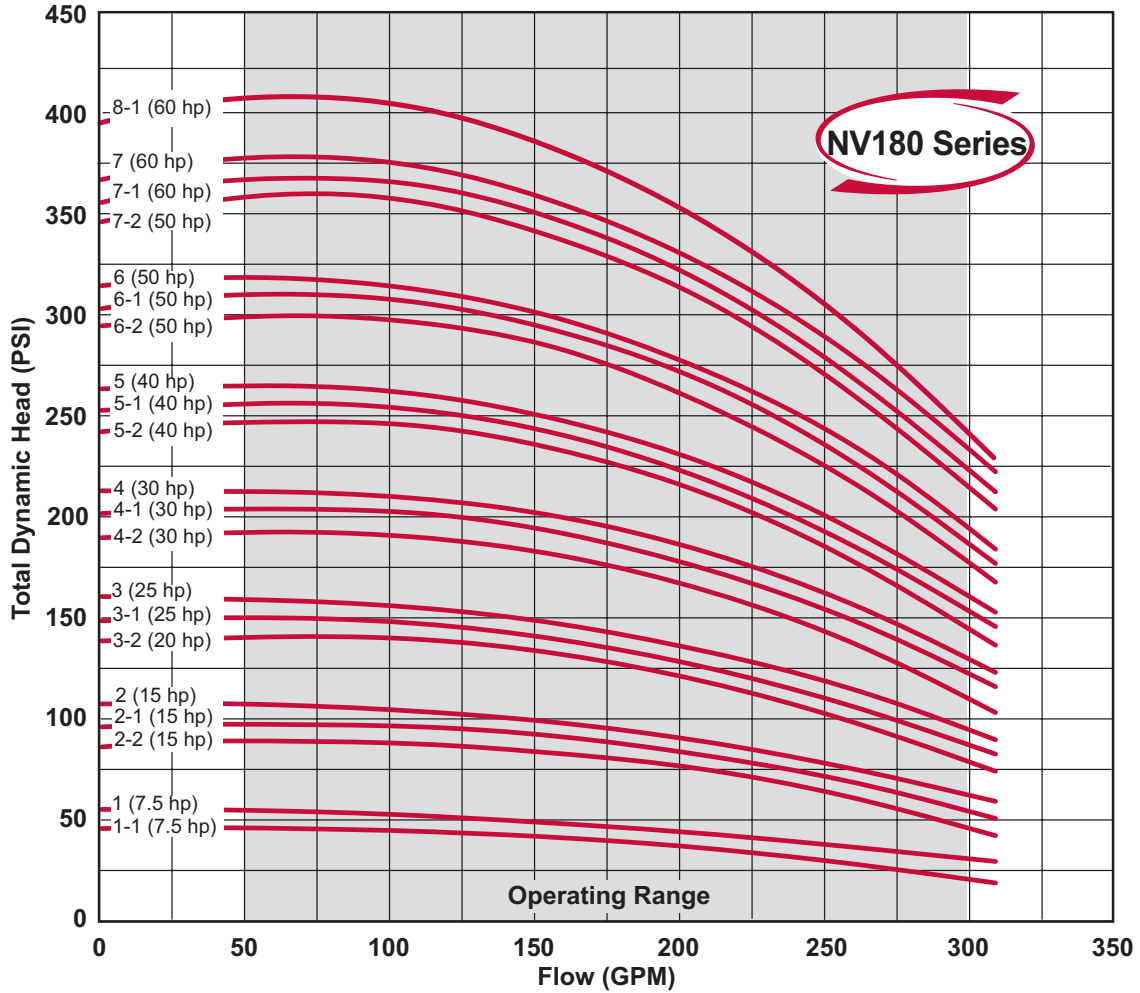

### NV280 PUMP DIMENSIONS

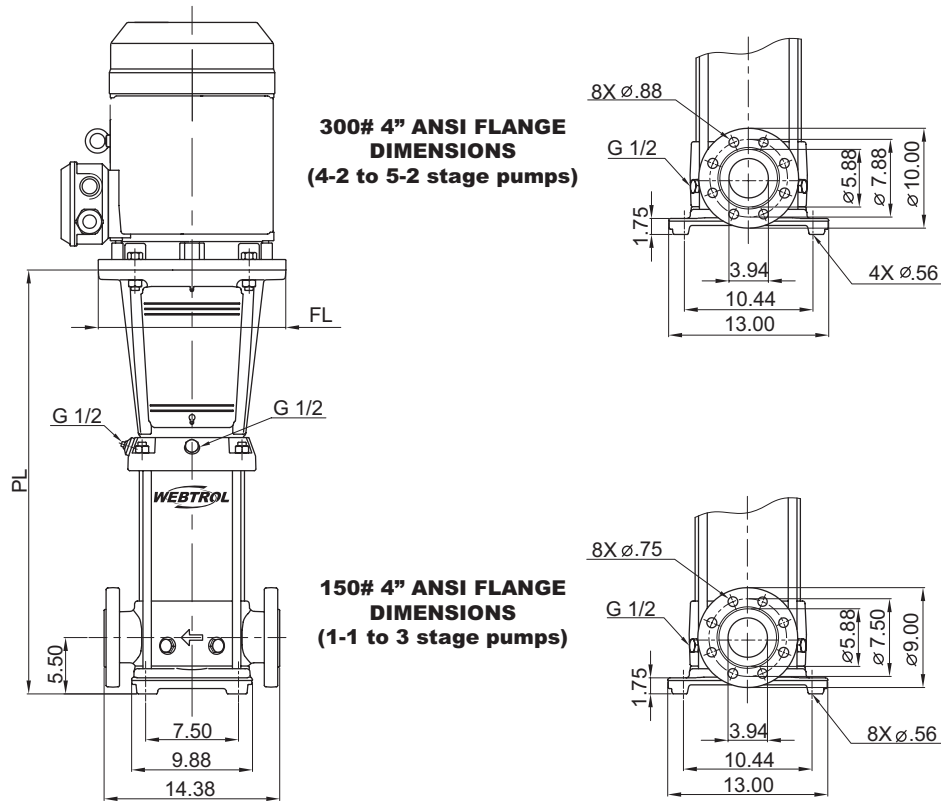

**NOTES:** All dimensions are in inches unless otherwise noted. Please contact factory for specific motor manufacturer dimensions

Model	HP	Motor Frame	Pump Length (PL) - in. Flange	Pump End Weight - lbs.
NV280B1-1	7.5	213TC	22.36	116
NV280B1	15	254TC	26.50	137
NV280B2-2	15	254TC	29.74	145
NV280B2-1	20	254TC	29.74	145
NV280B2	25	284TSC	29.74	148
NV280B3-2	30	286TSC	32.99	156
NV280B3-1	40	286TSC	32.99	156
NV280B3	40	286TSC	32.99	156
NV280B4-2	40	286TSC	36.24	164
NV280B4-1	50	326TSC	36.24	182
NV280B4	50	326TSC	36.24	182
NV280B5-2	60	364TSC	39.49	182

## NV280 SERIES GROUP CURVES

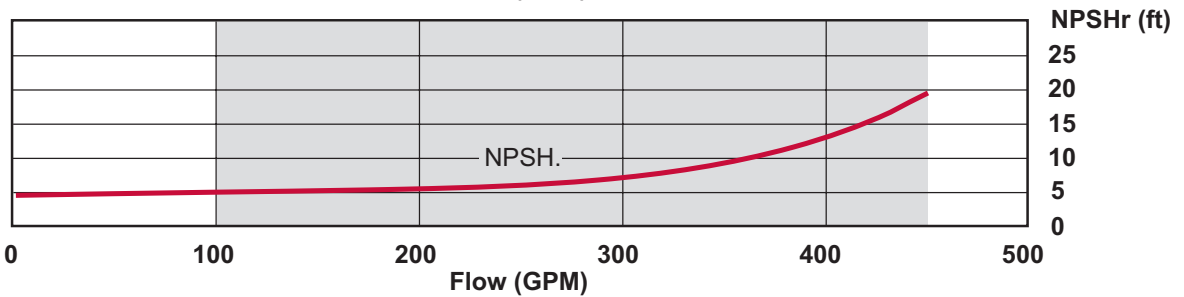
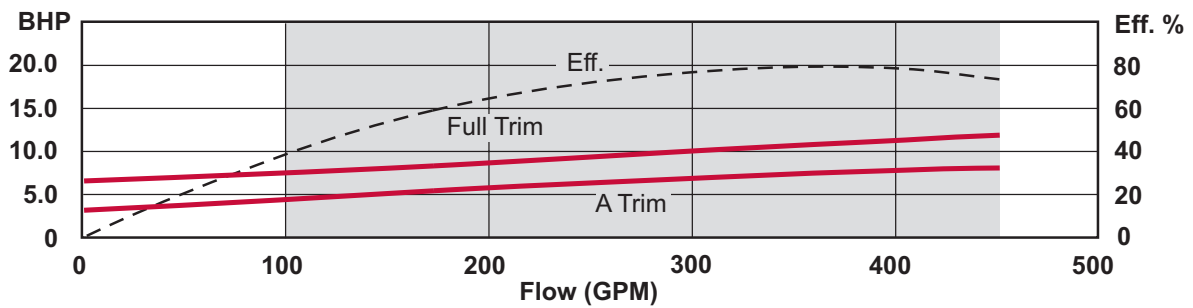
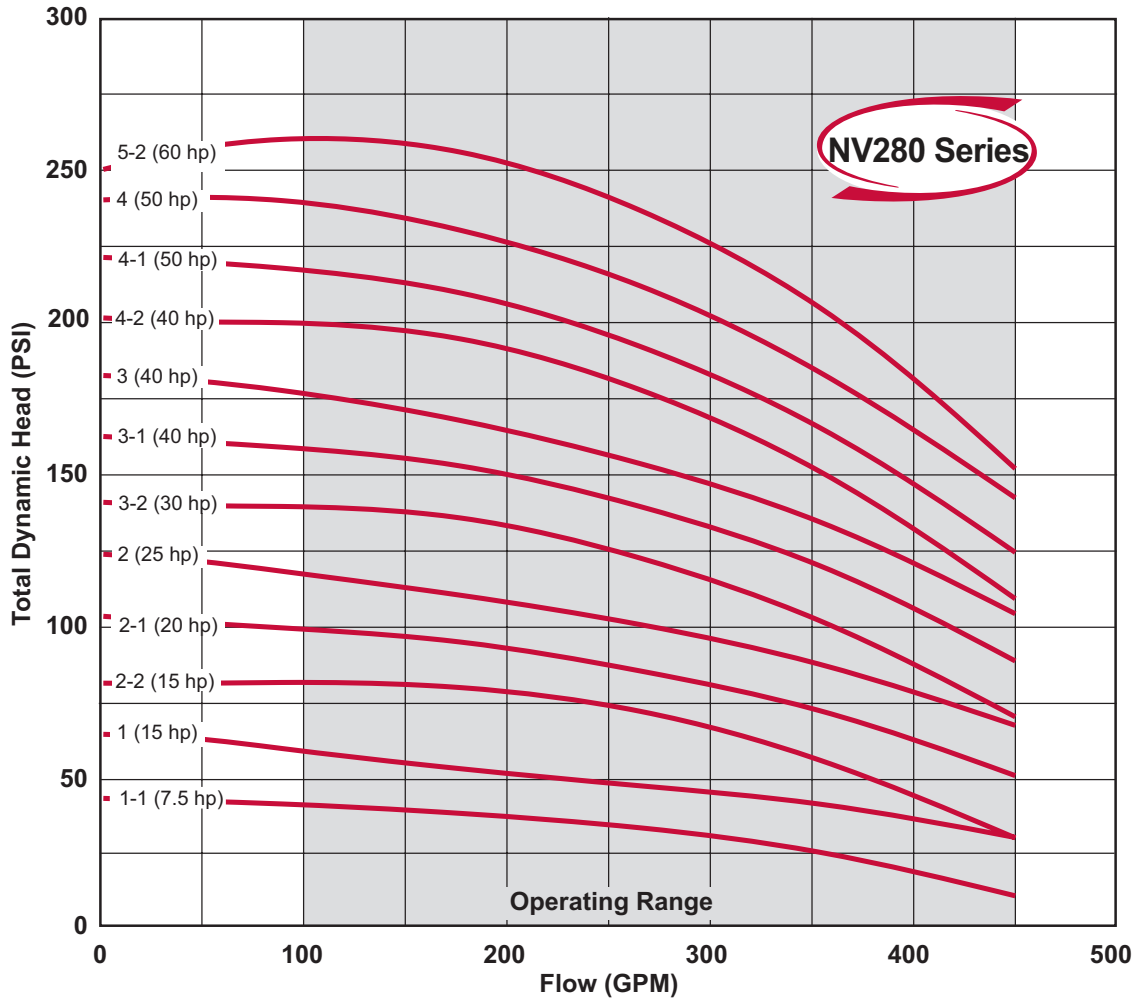

### NV400 PUMP DIMENSIONS

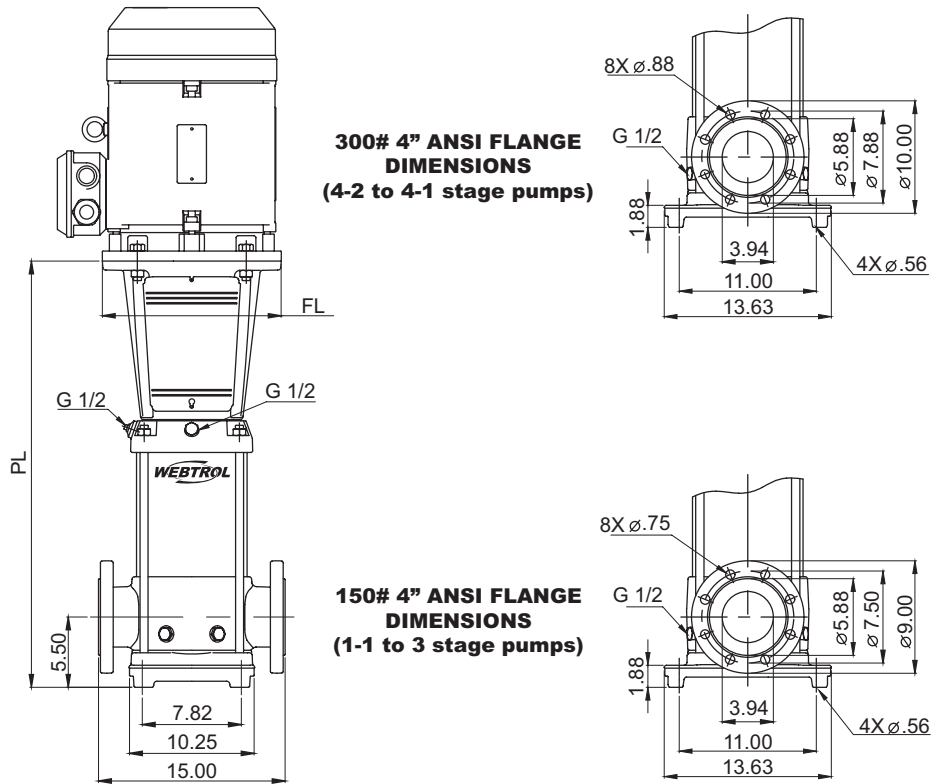

**NOTES:** All dimensions are in inches unless otherwise noted. Please contact factory for specific motor manufacturer dimensions

Model	HP	Motor Frame	Pump Length (PL) -in. Flange	Pump End Weight - lbs.
NV400B1-1	15	254TC	26.75	160
NV400B1	15	254TC	26.75	160
NV400B2-2	25	284TSC	30.34	173
NV400B2-1	30	286TSC	30.34	173
NV400B2	40	286TSC	30.34	173
NV400B3-2	40	286TSC	33.93	184
NV400B3-1	50	326TSC	33.93	202
NV400B3	50	326TSC	33.93	202
NV400B4-2	60	364TSC	37.36	217
NV400B4-1	60	364TSC	37.36	217



There when you need us most

## NV400 SERIES GROUP CURVES

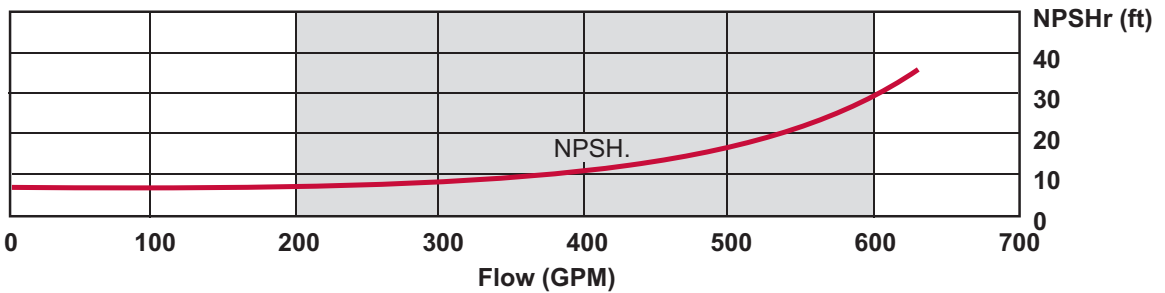
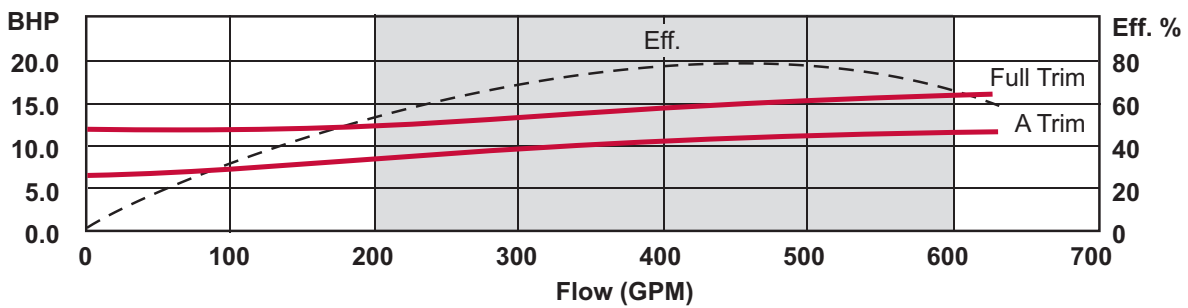
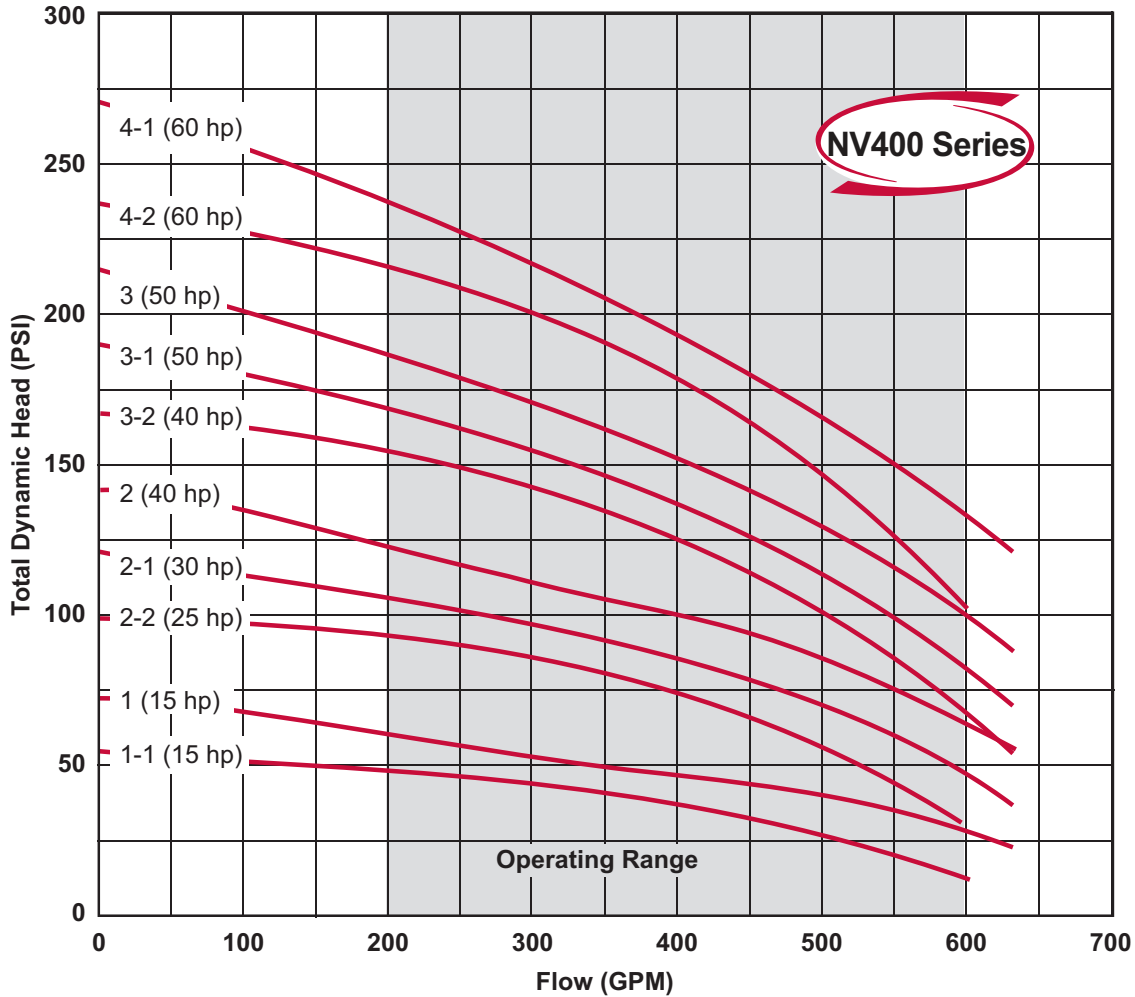



There when you need us most

### NOTES

---

---

---

---

---

---

---

---

---

---

---

---

---

---

---

---

---

---

---

---

---

---

---

---

---

---

---

---

---

## HT SERIES BOOSTER PUMPS

### Cast Iron and Stainless Steel Booster Pumps

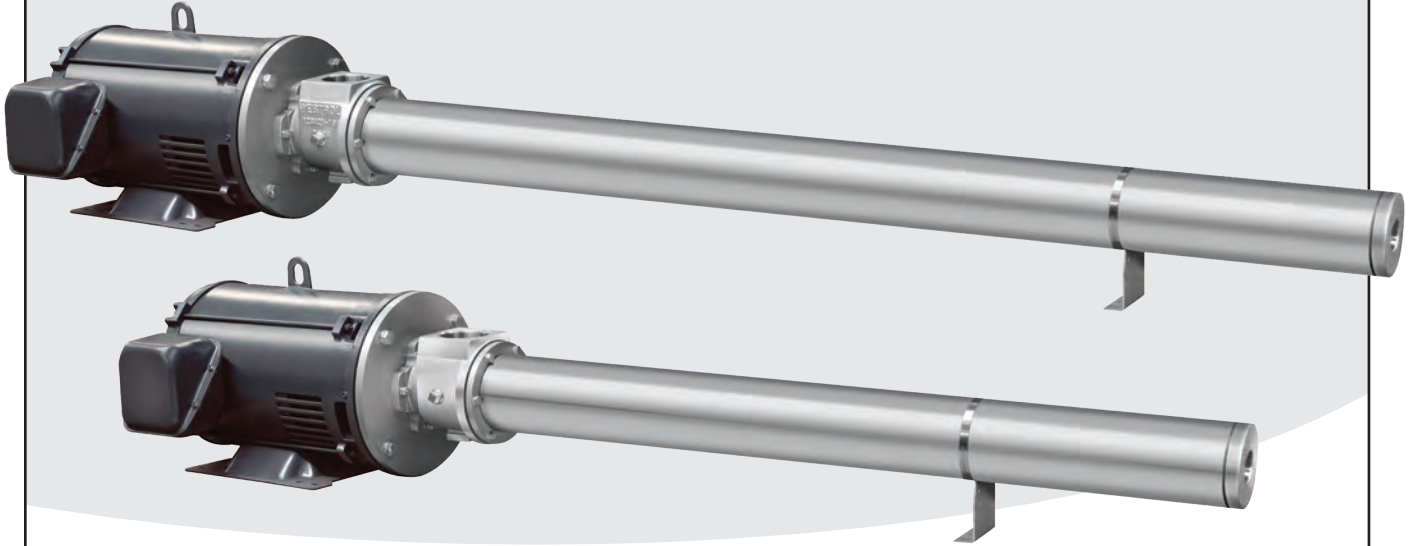

## HT Series

The Webtrol HT Series is the *original heavy duty booster pump* designed for high flow at high head to meet the demands of industrial, commercial, and agricultural applications.

### Features and Benefits

---

- Heavy duty 7/8" diameter stainless steel shaft with a double keyway
- Glass filled Noryl® impellers
- Injection molded, Polycarbonate, or Noryl diffusers with stainless steel wear rings

### Performance

---

HP Range: 5 to 40 HP, 60Hz

Capacities to 100 GPM

Pressures to 780 PSI

Temperatures to 180 °F

The quality and performance you expect, along with industry best lead times and personalized service, only from Webtrol!

### Typical Services

---

- Reverse Osmosis
- Deionization
- Car Wash
- Washdown
- Water Boosting

## HT SERIES BOOSTER PUMP

### Construction & Design Features

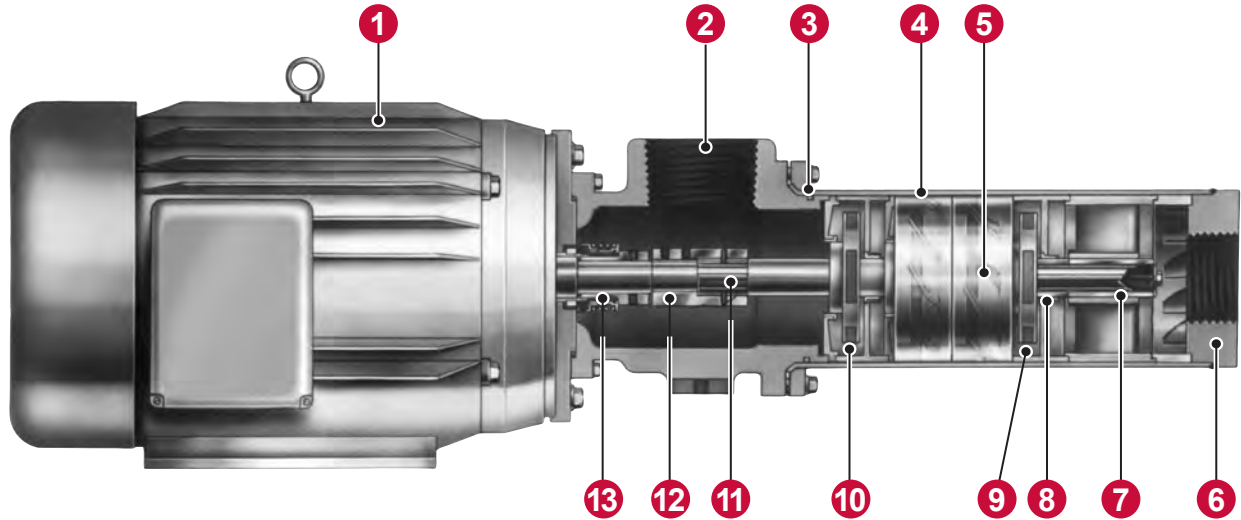

CONSTRUCTION MATERIALS		
Part	Cast Iron	Stainless Steel
Inlet/Motor Bracket	Cast Iron	316 SS
Discharge Housing	Steel	316 SS
Pump Housing	304 SS Tubing	316 SS Tubing
Impellers	Noryl®	Noryl®
Diffusers	Noryl®	Noryl®
Wear Rings	316 SS	316 SS
Shaft & Coupling	316 SS / 416 SS	316 SS
Shaft Bearing Sleeve	316 SS	316 SS
Shaft Bearing	Bronze	Rulon®
Mechanical Seal	Carbon/Ceramic 302 SS, Buna-N	Carbon/Ceramic 316 SS, Viton™
Mechanical Seal Spacer	416 SS	316 SS
O-Rings	Buna-N	Viton™



## HT SERIES BOOSTER PUMP



### Construction & Design Features

- 1** Closed coupled pump motor with a “C” face, 3450 RPM, 50 or 60 cycle, and a type JM mounting. Oversize ball bearings, class F insulation, and an external slinger ensure trouble free service. The direct coupling of the motor to the pump eliminates the need for a flexible coupling, guard, bearings, lubricator, oil seals, intermediate shaft, and bed plate. You won’t need to deal with troublesome field motor alignment, or noise, vibration, and eventual bearing or coupling failure caused by a misaligned motor.
- 2** Inlet/motor bracket is a heavy walled casting machined for perfect concentric and perpendicular alignment of the motor shaft with the pump shaft coupling. Inlet size is 3” female NPT.
- 3** Positive sealing Buna-N o-ring is used to seal off the inlet / motor bracket on cast iron models. A Viton™ o-ring is used on stainless steel models.
- 4** Thick-walled stainless steel pump housing is flared at one end to accept the inlet and welded at the discharge. Flaring allows the tube to be removed easily, unlike threaded pump housing which can be difficult if not impossible to remove because of galling.
- 5** The rotating assembly is comprised of the pump shaft and coupling assembly, bottom plate, impellers, diffusers, intermediate diffusers, intermediate and top sleeves and diffuser bearings. It is easily removed by loosening the sets screws in the coupling, unbolting the tube from the inlet, sliding the pump housing over the rotating assembly, and pulling the rotating assembly away from the inlet. The mechanical seal remains in place and undisturbed.
- 6** Welding the discharge to the pump housing makes mechanical seal replacement easy. It eliminates the need to unbolt or unscrew the discharge from the pump housing. A rabbet fit ensures that the diffusers are perfectly aligned when they are compressed within the pump housing. The discharge thread size is 1 1/2” female NPT.
- 7** Top shaft sleeve and bearing 316 SS shaft sleeve is water lubricated and runs in a Rulon® or bronze bearing that is molded into the top diffuser, then machined to close concentricity and bore tolerances. Longer pumps use several intermediate bearings to reduce shaft deflection, vibration, and stress.
- 8** Impeller wear rings are insert molded into each diffuser at both the suction and discharge side to eliminate plastic on plastic contact and maintain tight clearances for low leakage and high efficiency.
- 9** Diffuser assemblies, molded of Noryl® thermoplastic, are concentrically aligned together with rabbet fits and are compressed inside the pump housing to prevent interstage leakage and pressure loss.
- 10** Centrifugal impellers are Noryl® thermoplastic with keyed hubs, and generate pulse-free pressure at high efficiencies. All impellers and diffusers are injection molded at Weber Industries to insure control of dimensional accuracy and material specifications.
- 11** Oversized stainless steel pump shaft is supported by many intermediate bearings to minimize deflection, vibration and bending stresses. This combined with the elimination of any stress-rising, sharp internal keyway or spline corners allows you to run the pump without fear of vibration or shaft breakage.
- 12** 316 SS Coupling is first interference fit, then pinned and keyed to the pump shaft. It slips over the keyed motor shaft and is locked in place with set screws.
- 13** The spring loaded mechanical shaft seal has a ceramic stationary face and carbon rotating face. Metal components on the rotating half are 302 stainless steel and the elastomers are Buna-N (nitrile) for cast iron models, and Viton™ for stainless steel models. Because the seal is locked into position on the motor shaft by a separate stainless steel spacer, it is not disturbed when the rotating assembly is replaced. Maximum seal (inlet) pressure is 250 PSI.



There when you need us most

# HT Series

## HT SERIES FAMILY CURVES

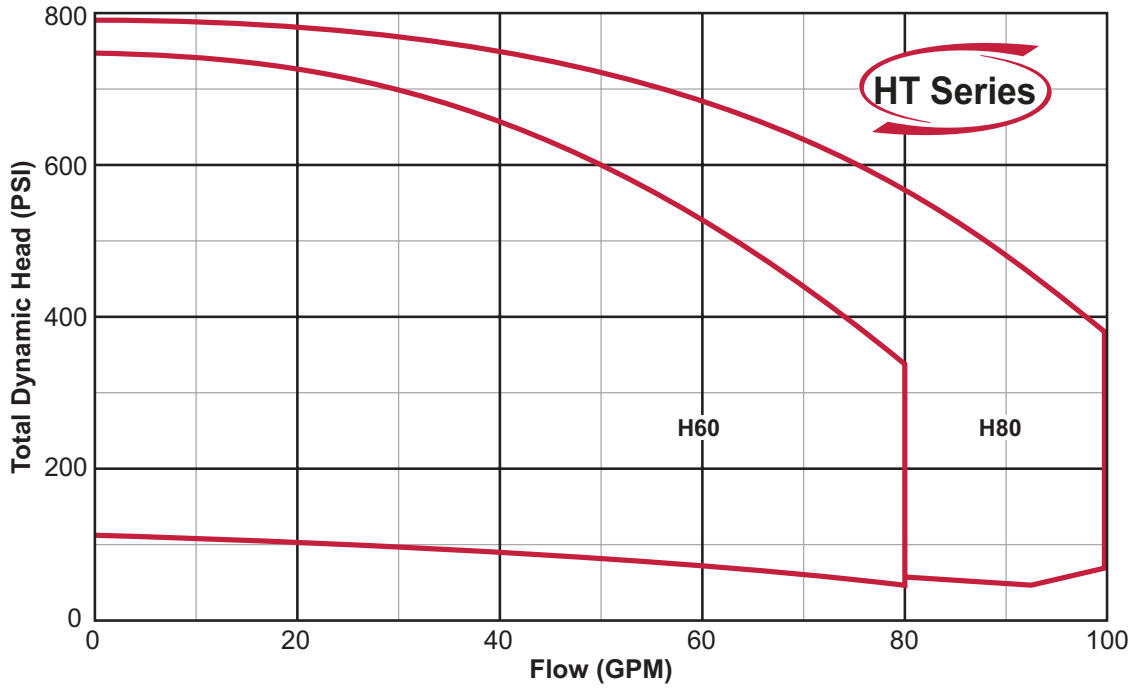

Note:  
HT Series curves in this catalog are based on 60 Hz 3450 rpm motors. 50 Hz 2875 rpm curves are available. These curves are for general guidance only, individual pump curves are available upon request. A certified curve may be requested for an additional cost. Webtrol will build pumps to fit your specific needs, contact factory for pricing.

## HT 60 SERIES GROUP CURVES

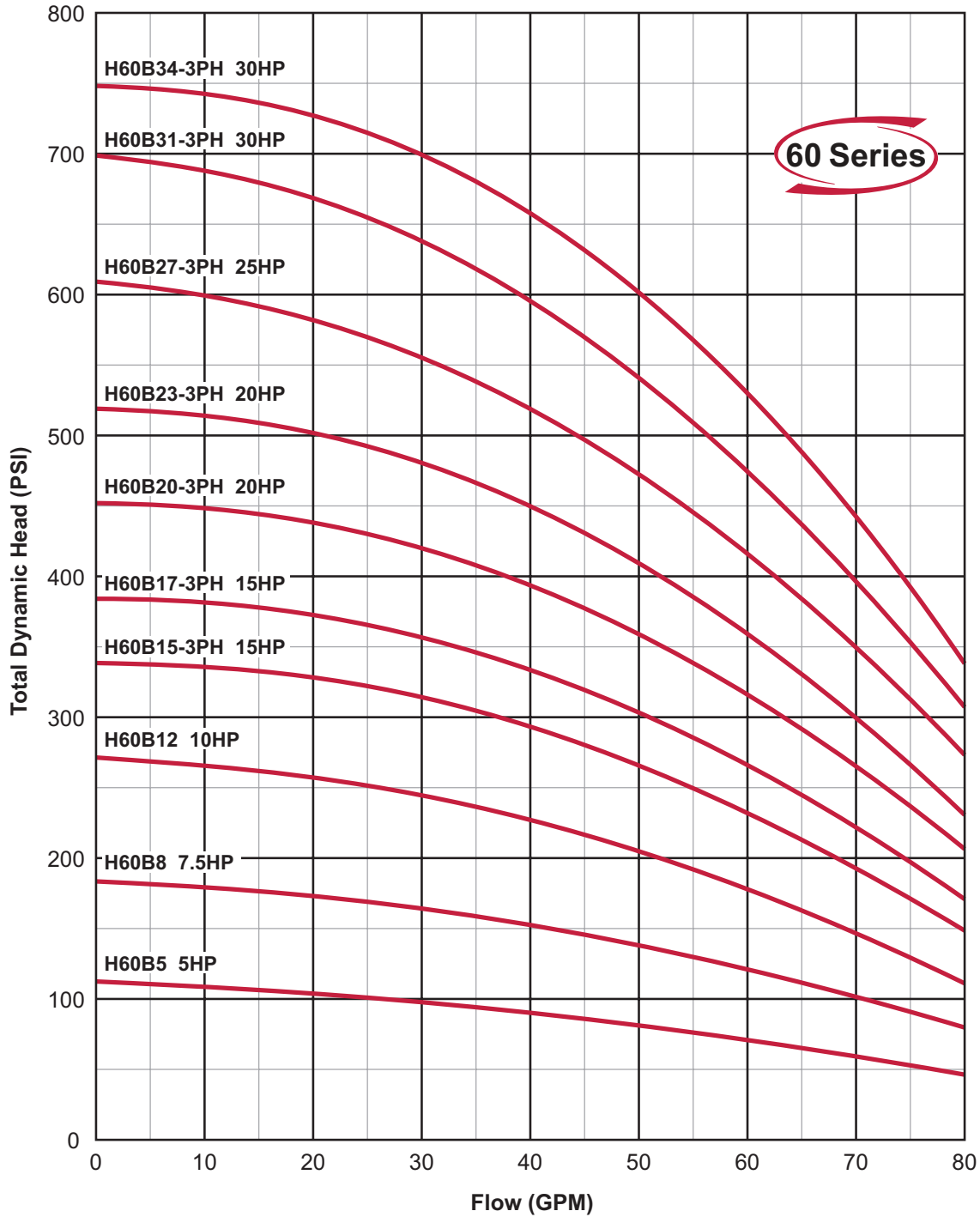



There when you need us most

# HT Series

## HT 80 SERIES GROUP CURVES

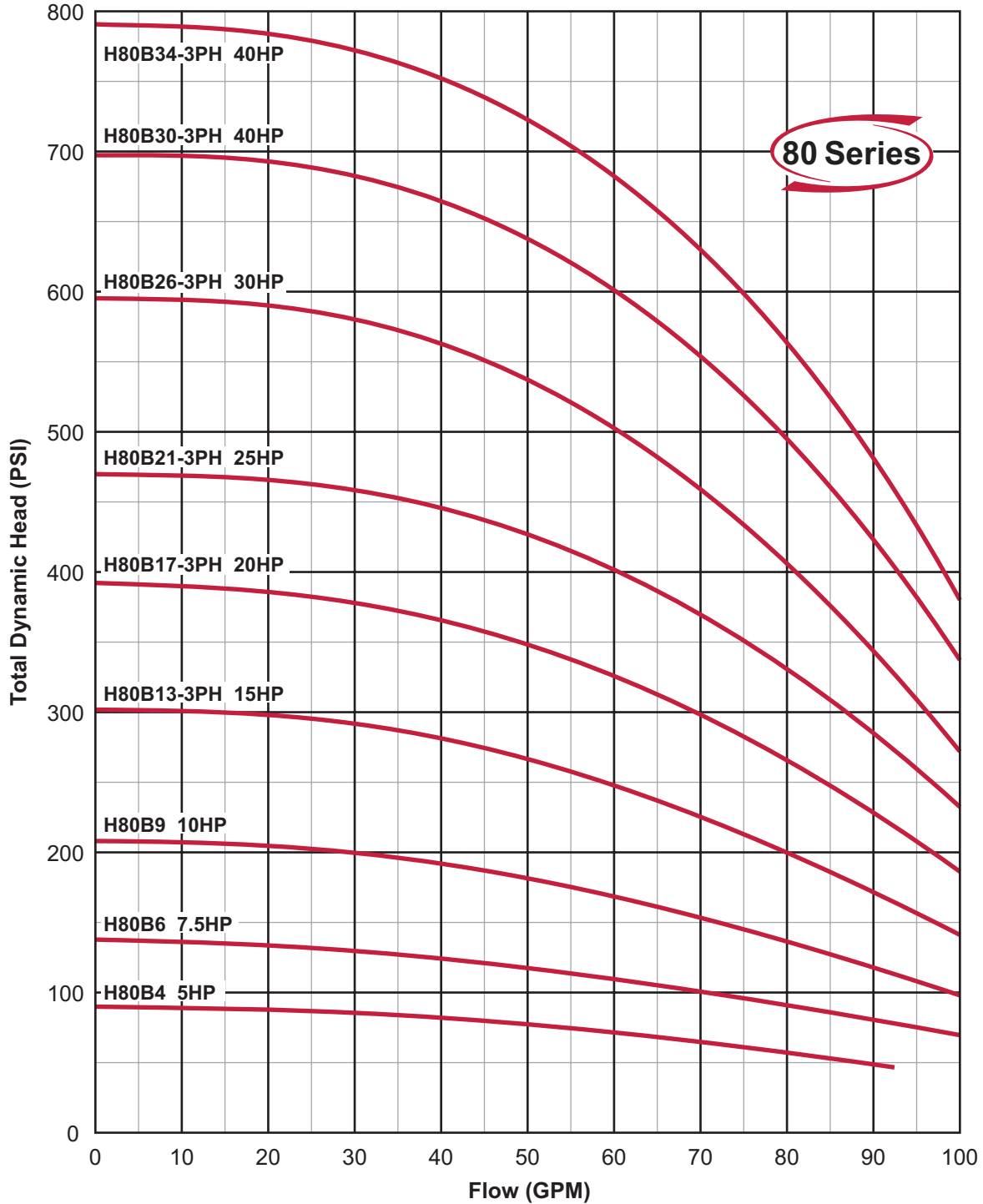

## HT SERIES DIMENSIONS

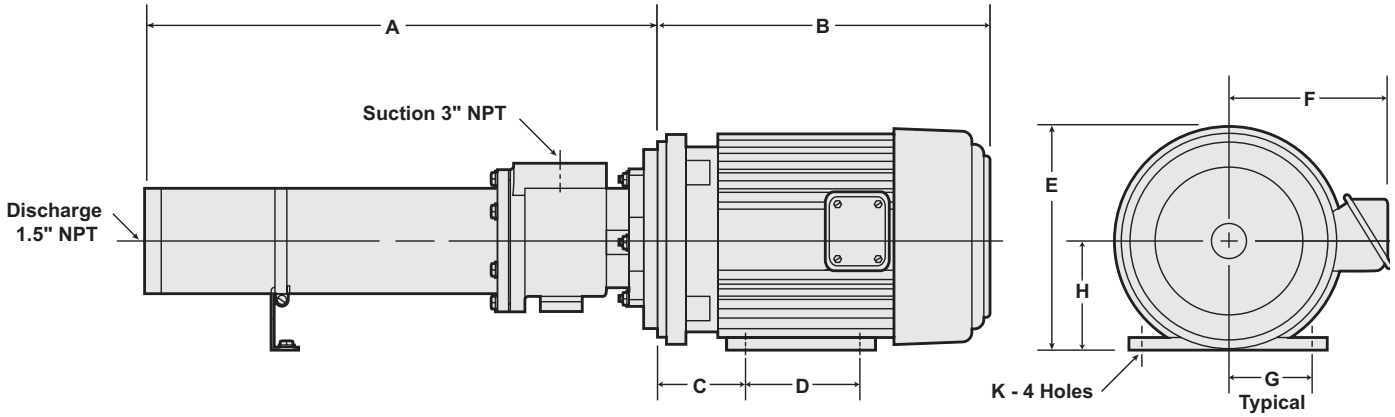

Cast Iron* 3PH TEFC Model No.	HP	Dimensions (inches)									Approx. Wt (lbs.)
		A	B	C	D	E	F	G	H	K	
H60B5-3PHT	5	20.80	12.97	3.50	5.50	10.34	6.43	3.75	4.50	0.41	132
H60B8-3PHT	7.5	26.20	18.84	3.50	5.50	10.34	6.43	3.75	4.50	0.41	149
H60B12-3PHT	10	32.60	15.47	4.50	7.00	11.12	6.43	4.25	5.25	0.41	204
H60B15-3PHT	15	40.00	20.05	4.25	8.25	14.94	10.00	5.00	6.25	0.53	250
H60B17-3PHT	15	43.20	20.05	4.25	8.25	14.94	10.00	5.00	6.25	0.53	258
H60B20-3PHT	20	48.10	20.05	4.25	8.25	14.94	10.00	5.00	6.25	0.53	295
H60B23-3PHT	20	52.90	20.05	4.25	8.25	14.94	10.00	5.00	6.25	0.53	306
H60B27-3PHT	25	62.00	23.25	4.75	9.50	16.35	12.09	6.38	7.00	0.53	357
H60B31-3PHT	30	64.40	24.17	4.75	9.50	16.93	12.20	5.50	7.00	0.53	408
H60B34-3PHT	30	72.80	24.17	4.75	9.50	16.93	12.20	5.50	7.00	0.53	420
H80B4-3PHT	5	19.70	12.97	3.50	5.50	10.34	6.43	3.75	4.50	0.41	141
H80B6-3PHT	7.5	23.70	18.84	3.50	5.50	10.34	6.43	3.75	4.50	0.41	151
H80B9-3PHT	10	28.90	15.47	4.50	7.00	11.12	6.43	4.25	5.25	0.41	188
H80B13-3PHT	15	38.00	20.05	4.25	8.25	14.94	10.00	5.00	6.25	0.53	238
H80B17-3PHT	20	45.40	20.05	4.25	8.25	14.94	10.00	5.00	6.25	0.53	278
H80B21-3PHT	25	52.40	23.25	4.75	9.50	16.35	12.09	6.38	7.00	0.53	329
H80B26-3PHT	30	63.70	24.17	4.75	9.50	16.93	12.20	5.50	7.00	0.53	388
H80B30-3PHT	40	70.70	24.37	5.25	10.50	18.16	13.74	6.25	8.00	0.66	495
H80B34-3PHT	40	77.60	24.37	5.25	10.50	18.16	13.74	6.25	8.00	0.66	515

\*Dimensions are the same for stainless steel models.



There when you need us most

### NOTES

Lined writing area with horizontal lines.

## IN-LINE SERIES BOOSTER PUMPS

### Cast Iron and Stainless Steel Booster Pumps

These heavy duty booster pumps are built for various flow rates at high heads, and designed to be whisper quiet.

The quality and performance you expect, along with industry best lead times and personalized service, only from Webtrol!



#### Features and Benefits

- Designed for various flow ranges at high heads
- Heavy duty, stainless steel cold drawn pump shaft
- High strength thermo-plastic impellers/diffusers
- Water cooled submersible motor for smooth, efficient and quiet operation

#### Performance

HP: 5 HP, 60Hz.

Capacities to 40 GPM

Pressures to 500 PSI

Temperatures to 122 °F

#### Typical Services

- Reverse Osmosis
- Deionization
- Car Wash
- Washdown
- Booster Lift Station
- Industrial
- Agricultural

## IN-LINE Series

## IN-LINE SERIES BOOSTER PUMP

### Construction & Design Features

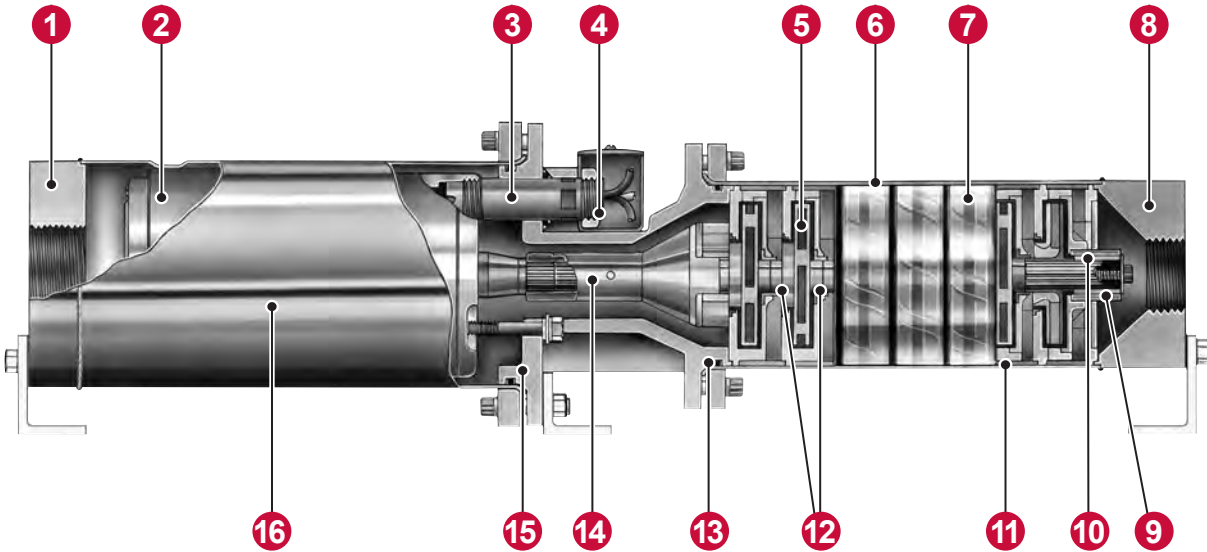

CONSTRUCTION MATERIALS		
Part	Cast Iron	Stainless Steel
Inlet/Motor Bracket	Cast Iron	Cast 316 SS
Discharge	316 SS	316 SS
Pump Housing	304 SS Tubing	316 SS Tubing
Motor Housing	316 SS	316 SS
Inlet	Steel	316 SS
Motor	316 SS	316 SS
Impellers	Noryl®	Noryl®
Diffusers	Noryl®	Noryl®
Wear Rings	316 SS	316 SS
Shaft & Coupling	Steel	316 SS
Shaft Sleeve & Bearing	Steel	316 SS
Shaft Bearing	Bronze	Rulon®
O-Rings	Viton™	Viton™

**NOTE:** A 60-80 GPM pump is shown, although a 5-35 GPM pumps are similar and have the same design features. Consult the service manual for repair parts illustrations.



## IN-LINE SERIES BOOSTER PUMP

### Construction & Design Features

## IN-LINE Series

- 1 Inlet** - Heavy-duty 316 SS with NPT connection is standard. Flange, sanitary, and victaulic fittings are available upon request. Maximum inlet pressure is 250 PSIG. Minimum inlet pressure is 2 PSIG because allowable motor temperature is based upon having at least atmospheric pressure on the water surrounding the motor. (optional steel construction available).
- 2 Motor** - Standard on 316 stainless steel In-Line Series Boosters are 316 SS continuous duty submersible motors (other options are available). These motors run extremely quiet due to the fact that they operate submerged in water. A Kingsbury pivoting shoe bearing is used to support the pump thrust load. Since, the bearing and motor are water lubricated, eliminating the need for mechanical seals. Motors are available in single or three phase, 60 cycle, and three phase 50 cycle. Motor will handle inlet water temperature up to 95 °F, however water temperature up to 122 °F can be used if the motor is derated.
- 3 Wiring** - Motor wiring is not contacted by the feed-water, therefore the motor cannot short out from breaks in the wiring insulation caused by chemical attack. Wiring connections are made with wire nuts contained inside a conduit box.
- 4 Up-Thrust Bearing** - The Rulon® upthrust bearing protects the pump from damage during startup.
- 5 Impellers** - Impellers are Noryl® polyphenylene oxide thermoplastic. The centrifugal design delivers a steady, pulse free flow with minimal noise and wear. All thermoplastic pump components are injection molded at Weber Industries to insure the strictest of "Quality Control Standards".
- 6 Pump Housing** - The 304/316 SS pump housing is bolted, not threaded to the motor bracket. Since, it is not enclosed by another tube, maintenance and priming is easy. Prior to servicing, the wiring and cord seal do not have to be disconnected nor does the pump and motor have to be pulled out of a tube. Air or stagnant pockets of water cannot be trapped near the discharge and delay priming.
- 7 Rotating Assembly** - The entire rotating assembly is easily removed by simply unbolting the pump housing from the motor bracket, and removing it. Then remove the rotating assembly by slipping it off the motor shaft.
- 8 Discharge** - Rugged heavy-duty 316 SS with NPT connection is standard. Flange and sanitary, fittings are available upon request. Maximum working pressure is 1000 PSIG for the 60 and 80 GPM series and 750 PSIG for the 5 thru 35 GPM series. Ease of removal is guaranteed by the welded discharge/tube assembly (optional steel construction available).
- 9 Top Shaft Sleeve and Bearing** - 316 SS shaft sleeve is water lubricated and runs in a Rulon® bearing that is molded into the top diffuser then machined to close concentricity and bore tolerances. Longer pumps use several intermediate bearings to reduce shaft deflections.
- 10 Shaft** - 316 SS shaft is cold drawn and straightened to tight tolerances to eliminate shaft whip and resulting vibration.
- 11 Diffusers** - Diffuser assemblies molded of Noryl® polyphenylene oxide thermoplastic are assembled using concentric rabbit fits. Inside the pump housing, they are compressed to prevent interstage leakage and loss of pressure which improves efficiency.
- 12 Impeller Wear Rings** - 316 SS stamped wear rings are insert molded into each diffuser at both the suction and discharge side to eliminate plastic on plastic contact and maintain tight clearances for low leakage and high efficiency. O-Rings - Viton™
- 13 "O" Rings** are used throughout for resistance to aggressive high purity water.
- 14 Coupling** - The 316 SS coupling of this pump is rugged and simple. It is pressed onto the pump shaft, pinned, and splined to correctly fit the motor shaft. This design insures reliable operation and long life. Set screws are not necessary so assembly is simplified.
- 15 Motor/Pump Bracket** - 316 SS motor bracket is standard (steel is available). This is precision investment casting, machined for perfect alignment of the motor shaft with pump shaft coupling. Ribbing adds strength and stiffness for horizontal mounting.
- 16 Motor Housing** - The 316 SS motor housing is designed to provide a minimum water velocity past 4" motors of 0.25 ft/sec (3 GPM). These minimum flow rates will prevent premature motor failure. This motor heated feedwater tends to improve the efficiency of RO membranes. Dimples in the highly polished housing located close to the inlet assist in supporting the motor.



There when you need us most

# IN-LINE Series

## IN-LINE SERIES FAMILY CURVES

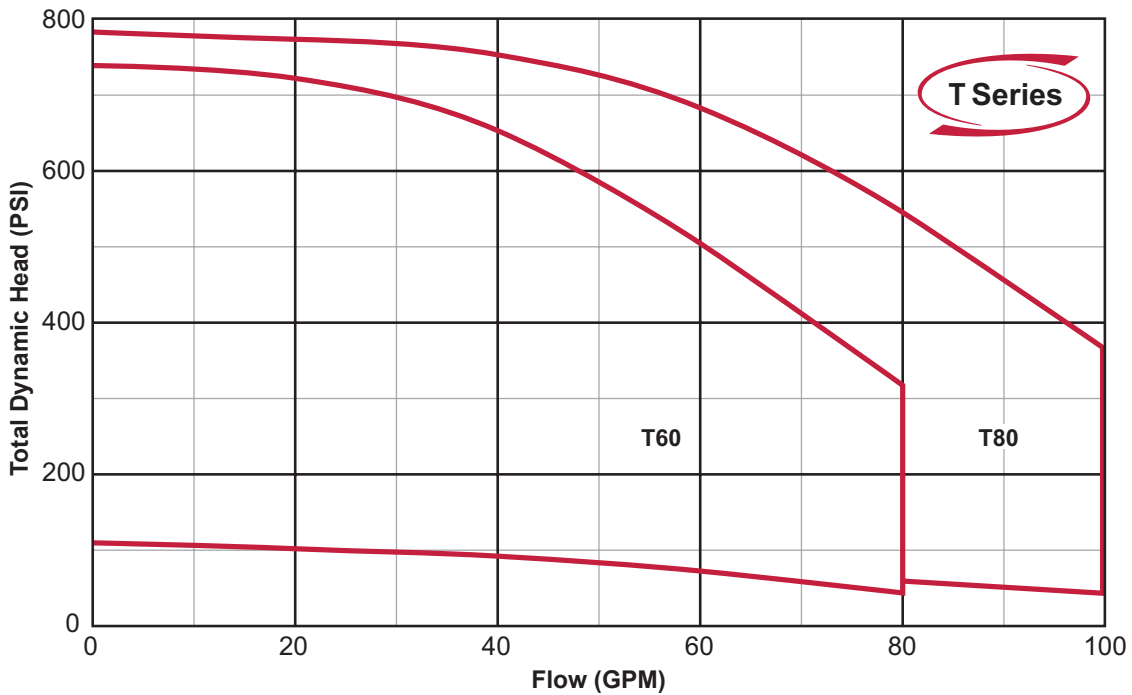
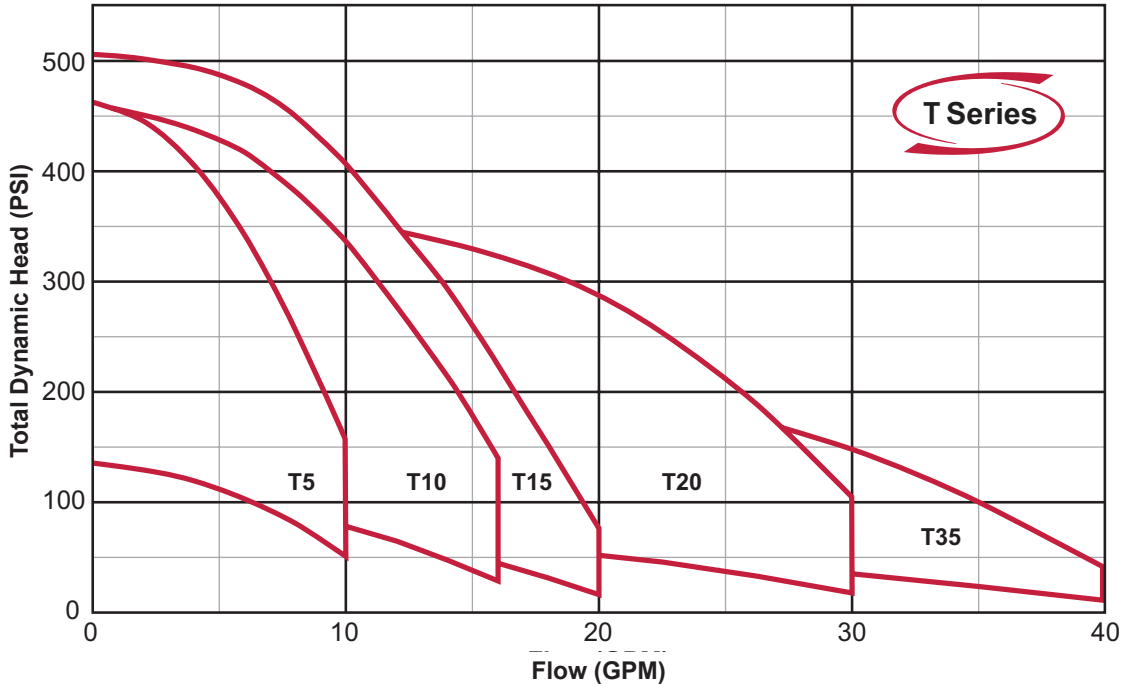



There when you need us most

## IN-LINE T5 SERIES GROUP CURVES

**IN-LINE**  
Series

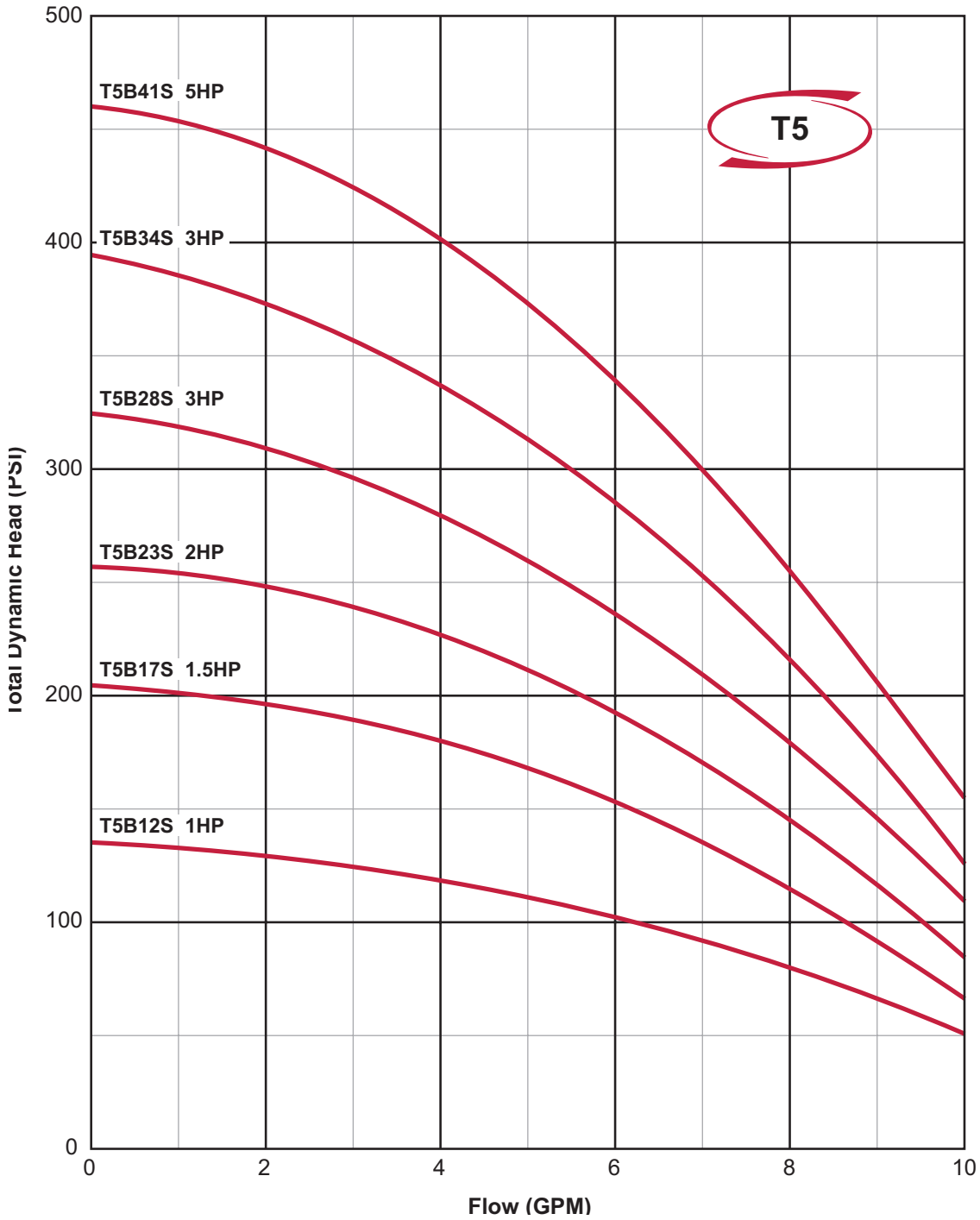



There when you need us most

**IN-LINE Series**

**IN-LINE T10 SERIES GROUP CURVES**

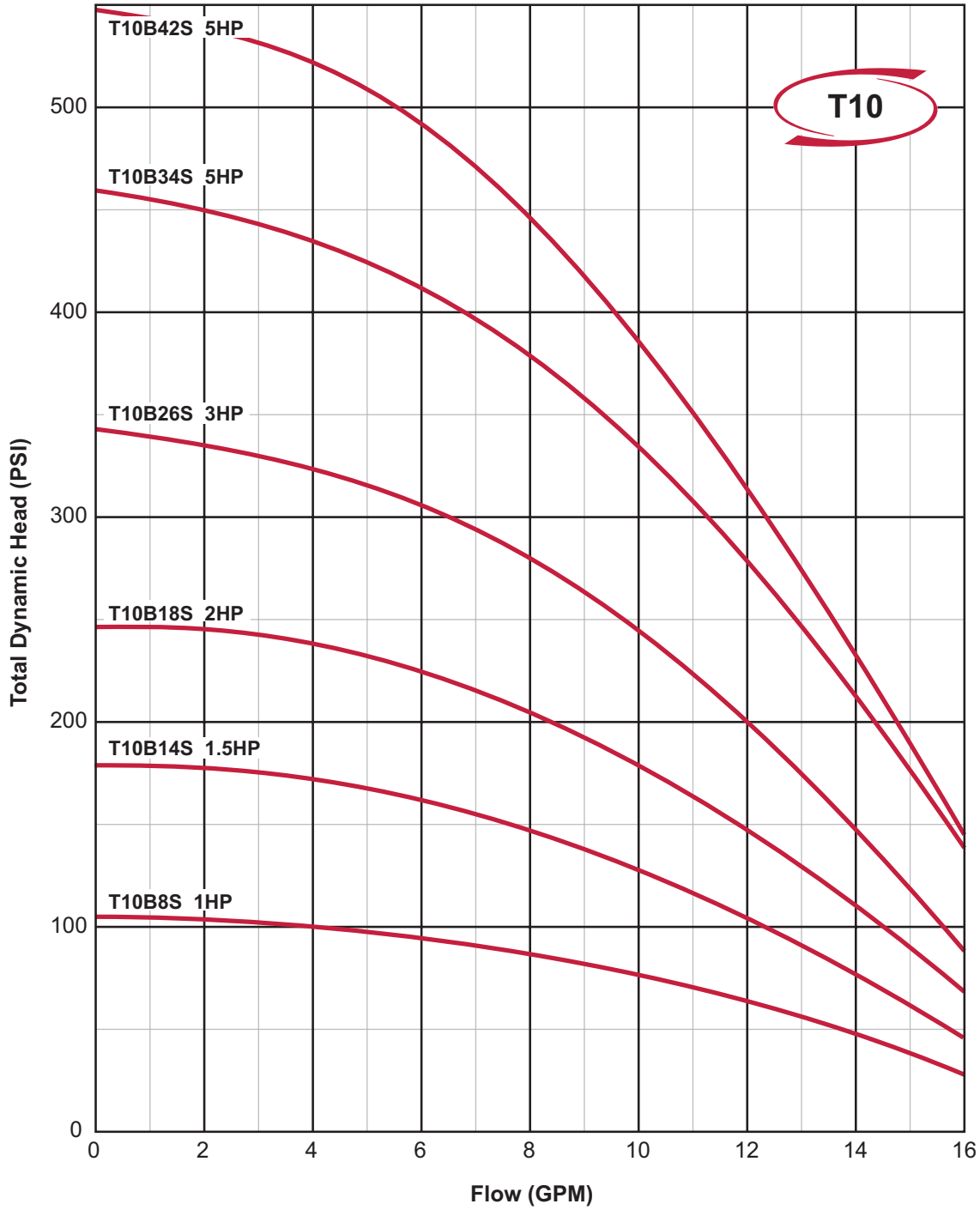



There when you need us most

## IN-LINE T15 SERIES GROUP CURVES

**IN-LINE**  
Series

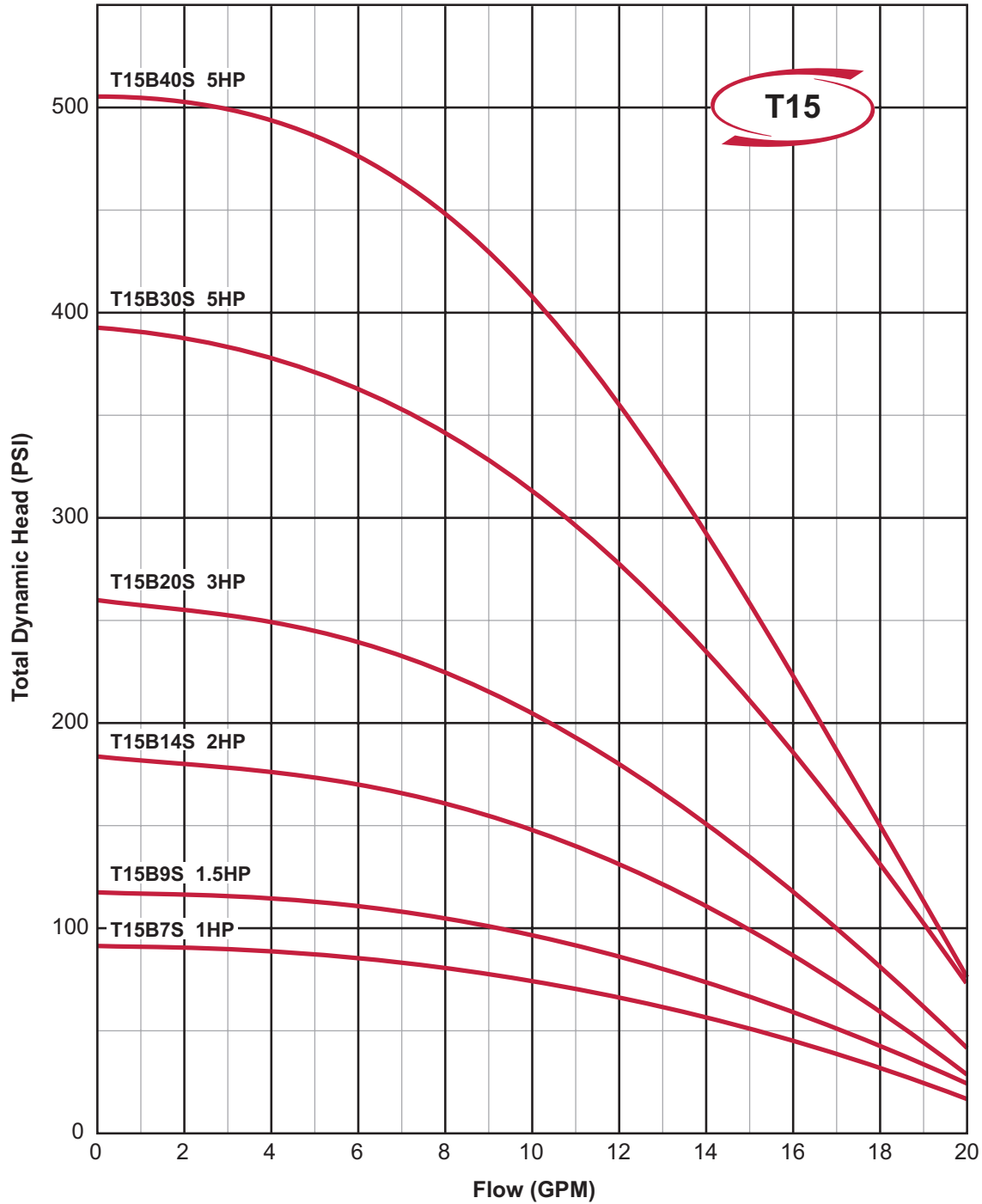



There when you need us most

**IN-LINE Series**

**IN-LINE T20 SERIES GROUP CURVES**

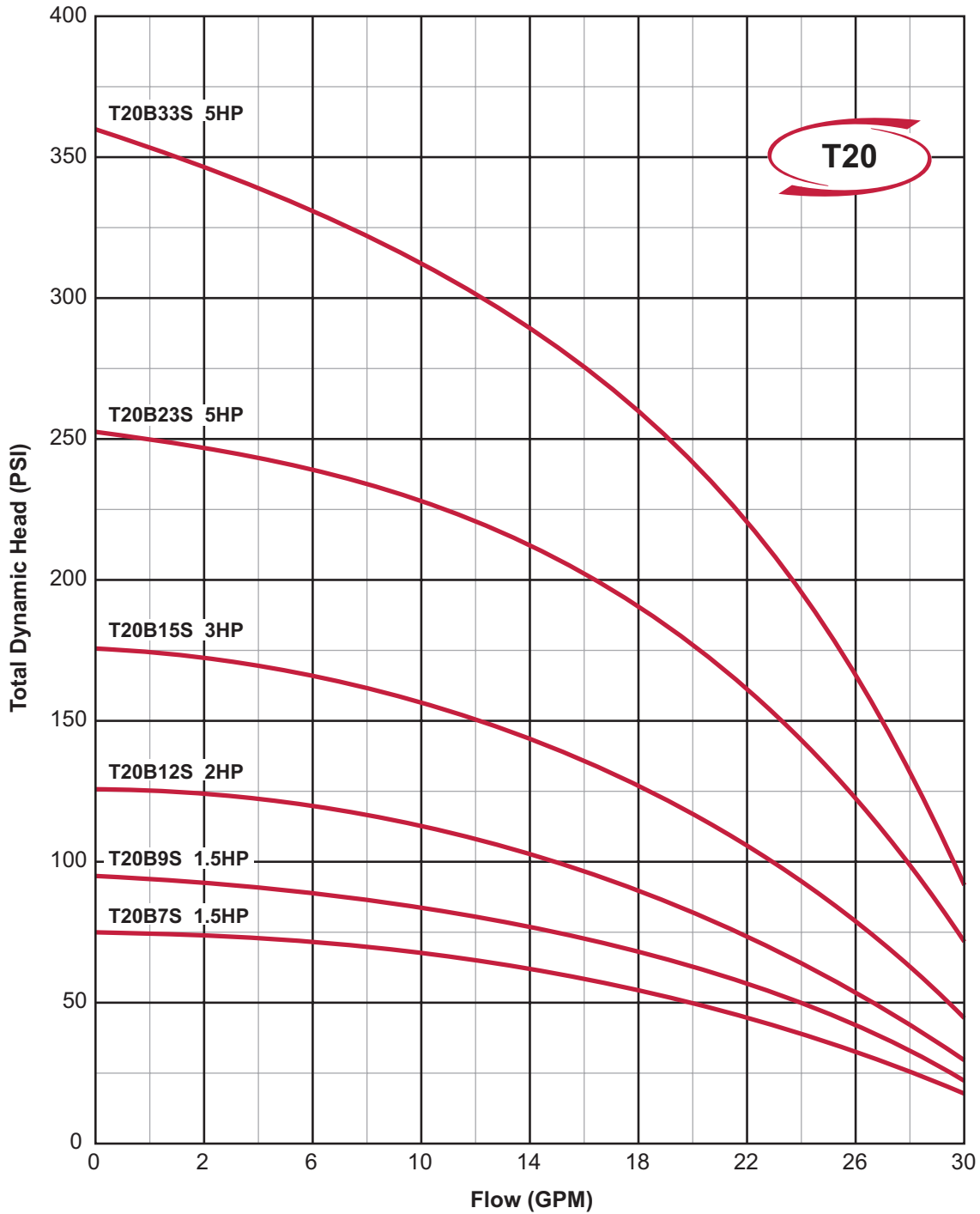

## IN-LINE T35 SERIES GROUP CURVES

## IN-LINE Series

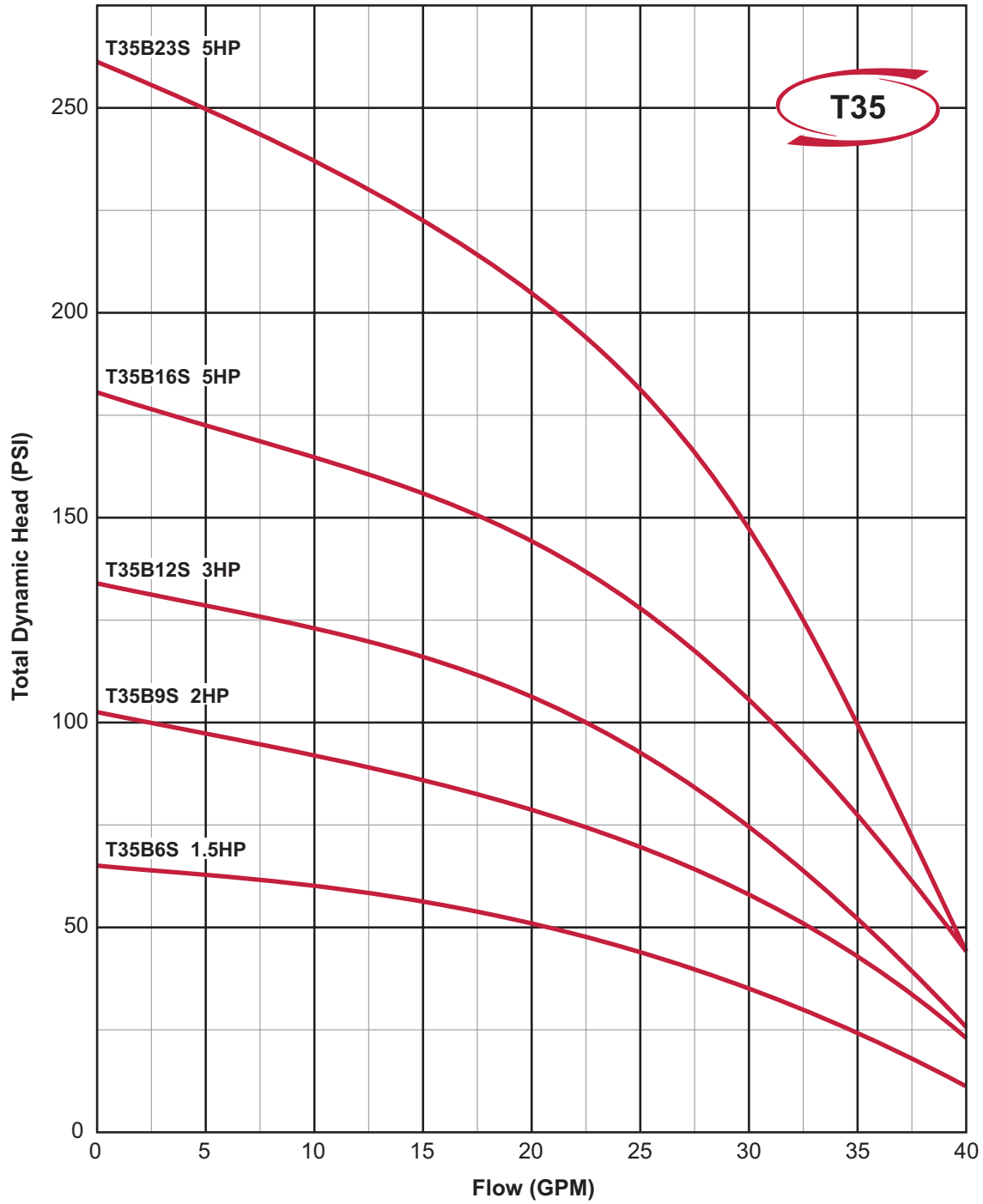

## IN-LINE Series

## IN-LINE SERIES DIMENSIONS 5, 10, 15, 20 & 35 Series

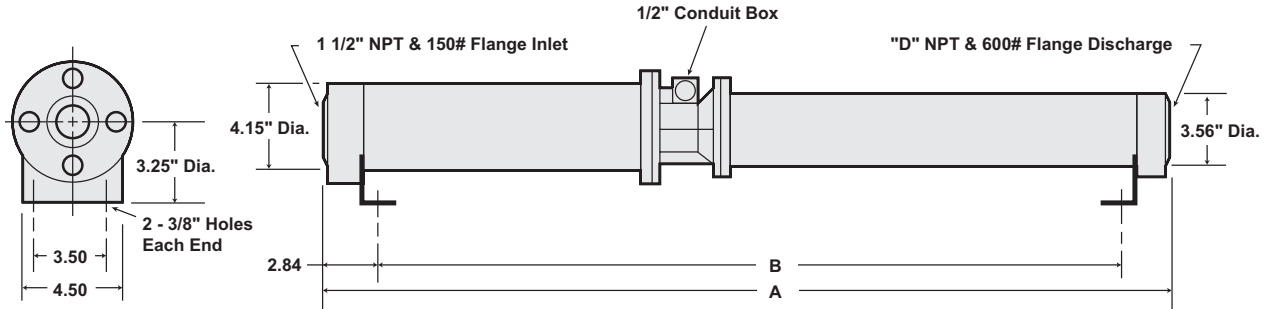

Model No.	HP	A		B		C	D	Pump Weight (lbs)	
		1 Phase	3 Phase	1 Phase	3 Phase			1 Phase	3 Phase
T5B12S	1	33.8	32.8	29.0	28.0	5.0	1	75	73
T5B17S	1.5	45.9	44.8	41.1	40.0	5.0	1	83	81
T5B23S	2	53.8	52.3	49.0	47.5	5.0	1	91	90
T5B28S	3	61.3	58.4	56.0	53.6	5.0	1	104	95
T5B34S	3	67.8	64.9	63.0	60.1	5.0	1	109	100
T5B41S	5	80.2	74.2	75.4	69.4	5.0	1	131	115
T10B8S	1	30.0	29.3	25.5	24.5	5.0	1	74	72
T10B14S	1.5	42.6	41.5	37.8	36.7	5.0	1	82	80
T10B18S	2	48.8	47.3	44.0	42.5	5.0	1	90	89
T10B26S	3	60.2	57.4	55.4	52.6	5.0	1	103	94
T10B34S	5	74.8	68.8	70.0	64.0	5.0	1	129	113
T10B42S	5	82.4	76.4	77.6	71.6	5.0	1	132	116
T15B7S	1	29.8	28.8	25.0	24.0	5.0	1	74	72
T15B9S	1.5	38.4	37.3	33.6	32.5	5.0	1	80	78
T15B14S	2	46.0	44.5	41.2	39.7	5.0	1	82	80
T15B20S	3	54.9	52.0	50.1	47.2	5.0	1	101	92
T15B30S	5	72.0	66.0	67.2	61.2	5.0	1	127	111
T15B40S	5	83.1	77.1	78.3	72.3	5.0	1	131	115
T20B7S	1.5	37.8	36.6	33.2	32.1	5 3/4	1 1/2	77	75
T20B9S	1.5	40.2	39.1	35.7	34.6	5 3/4	1 1/2	79	77
T20B12S	2	46.7	45.2	42.2	40.7	5 3/4	1 1/2	81	79
T20B15S	3	53.3	50.4	48.7	45.9	5 3/4	1 1/2	100	91
T20B23S	5	70.5	64.5	65.9	59.9	5 3/4	1 1/2	126	110
T20B33S	5	84.1	78.1	79.6	73.6	5 3/4	1 1/2	130	114
T35B5S	1.5	36.1	35.0	31.6	30.5	5 3/4	1 1/2	77	75
T35B6S	1.5	37.6	36.4	33.0	31.9	5 3/4	1 1/2	78	76
T35B9S	2	43.3	41.8	38.7	37.2	5 3/4	1 1/2	80	78
T35B12S	3	50.4	47.5	45.8	43.0	5 3/4	1 1/2	98	89
T35B16S	5	63.5	57.5	58.9	52.9	5 3/4	1 1/2	119	103
T35B23S	5	73.3	67.3	68.8	62.8	5 3/4	1 1/2	127	111



## ACE SERIES CENTRIFUGAL PUMPS

### Cast Iron End Suction Pumps

# ACE Series

ACE Series Centrifugal Pumps are close coupled end suction centrifugals that provide you with reliable solutions for industrial, commercial, and agricultural applications.

The quality and performance you expect, along with industry best lead times and personalized service, only from Webtrol!



#### Features and Benefits

- Enclosed glass filled Noryl® impeller resistant to corrosion and abrasion
- 3 and 5 HP pumps feature cast iron impellers
- Top located discharge for easy air bleeding and self venting when used in hot water applications
- Stainless steel and Buna-N rubber mechanical seals
- Open drip proof design with thermal overload protection

#### Performance

HP Range: .5 - 5 HP, 60Hz.  
Capacities to 150 GPM  
Pressures to 158 Ft  
Temperatures to 200 °F

#### Typical Services

- Farm Irrigation
- Lawn Sprinklers
- Pressure Boosting
- Circulation Pumps
- Hot Water or Glycol Circulation

## ACE Series

## ACE CENTRIFUGAL PUMP Performance Curves & Dimensions

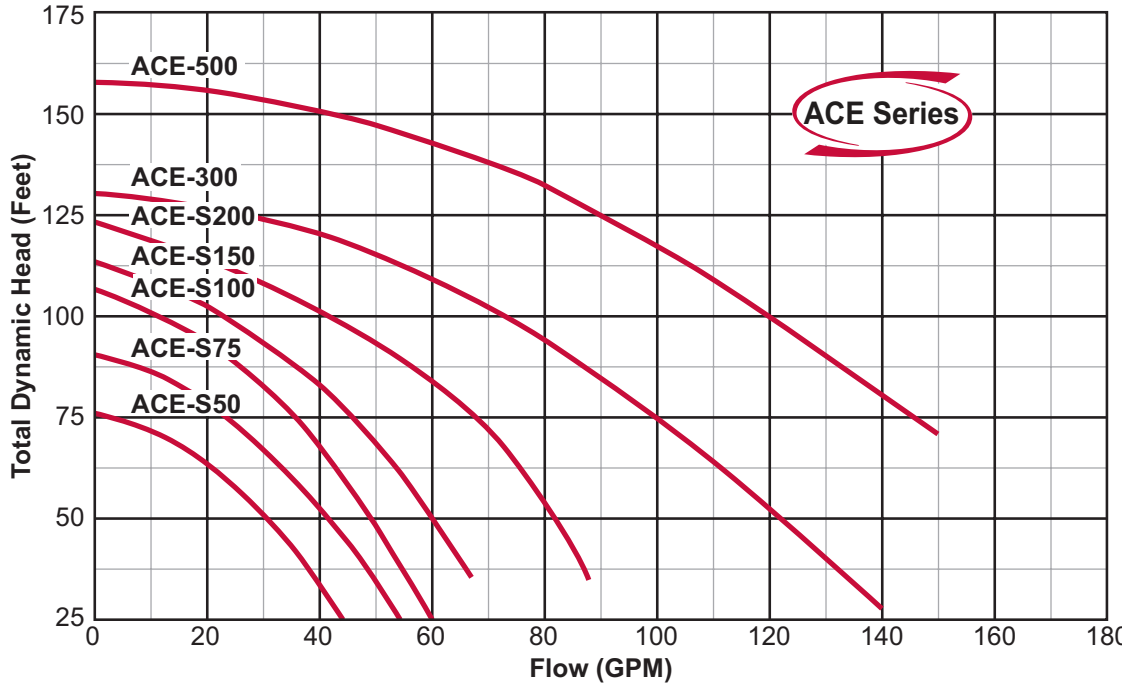

Model No.	HP	NPT		CP	D	E	F	H	L	M	N	OP	X	Y
		Suction	Discharge											
ACE-S50	.5	1.25	1	13.75	4.00	4.88	3.00	7/16 x 15/16	5.53	3.69	4.00	8.90	4.90	2.63
ACE-S75	.75	1.25	1	14.07	4.00	4.88	3.00	7/16 x 15/16	5.53	3.69	4.00	8.90	4.90	2.63
ACE-S100	1	1.25	1	15.57	4.00	4.88	3.00	7/16 x 15/16	5.53	3.69	4.00	8.90	4.90	2.63
ACE-S150	2.5	1.25	1	15.90	4.00	4.88	3.00	7/16 x 15/16	5.53	3.69	4.00	8.90	4.90	2.63
ACE-S200	2	1.5	1.25	15.82	4.46	4.88	3.00	-	5.88	4.12	4.72	10.78	6.31	2.88
ACE-300	3	2	2	17.25	4.99	5.75	-	-	8.79	4.12	5.69	10.37	6.31	3.25
ACE-500	5	2	2	19.00	4.05	7.50	5.50	-	8.79	4.12	5.69	10.37	6.31	3.25

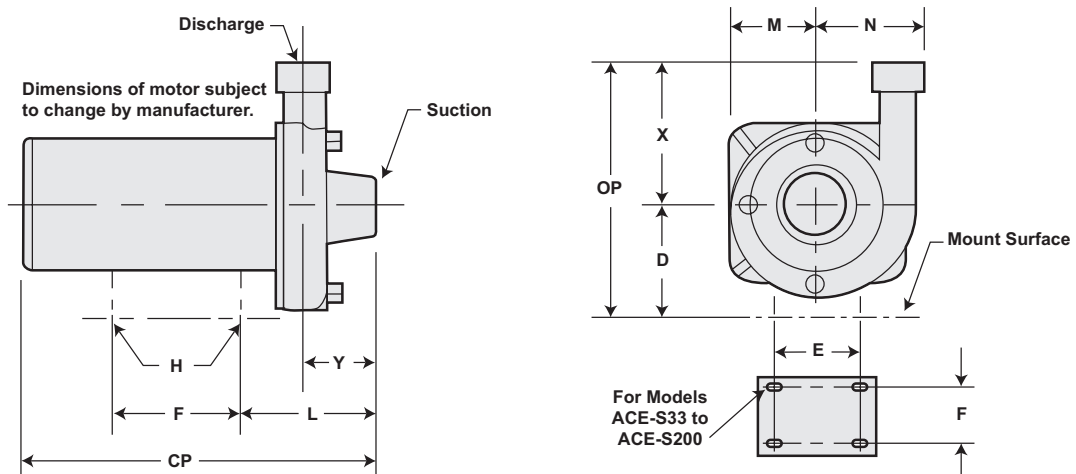

## PC SERIES CENTRIFUGAL PUMPS

### Corrosion Resistant Centrifugal Pumps

## PC Series

The compact, lightweight design of the PC Series pumps makes it ideal for cabinet installation, as well as skid mounting. They are corrosion resistant to provide you with reliable solutions for a variety of industrial, commercial, and agricultural applications.

The quality and performance you expect, along with industry best lead times and personalized service, only from Webtrol!



#### Features and Benefits

- Close coupled for a smooth transmission of power
- 316 stainless steel wear ring and impeller hub for long pump life
- Glass reinforced Noryl® pump case, motor bracket, and impeller
- Ease of Installation with the ability to rotate the discharge in 90° increments
- Suction pressures to 35 PSI (with 50 PSI boost)
- Mechanical seal type 6, 316 SS & Viton™

#### Performance

HP Range: .5 to 1.5 HP, 60Hz  
Capacities to 65 GPM  
Pressures to 50 PSI  
Temperatures to 180 °F

#### Typical Services

- Deionized Systems
- Reverse Osmosis Systems
- Distribution Systems
- Car Wash Systems
- Liquid Transfer Systems
- Circulation Systems
- Pre-Filter Charge System
- Condensation Systems
- Cooling Tower Systems



There when you need us most

**PC Series**

## PC SERIES GROUP CURVES

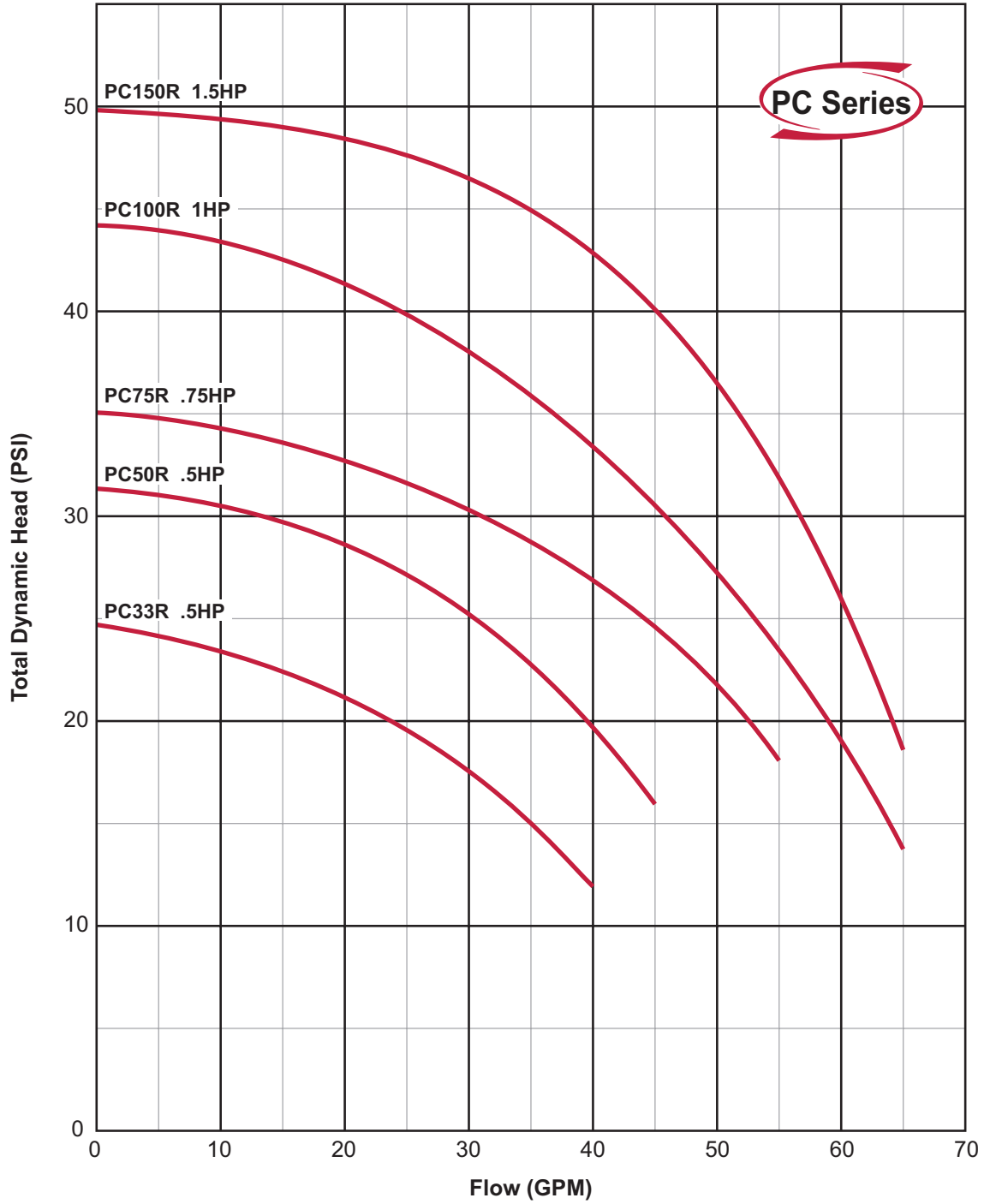



There when you need us most

## PC SERIES GROUP CURVES

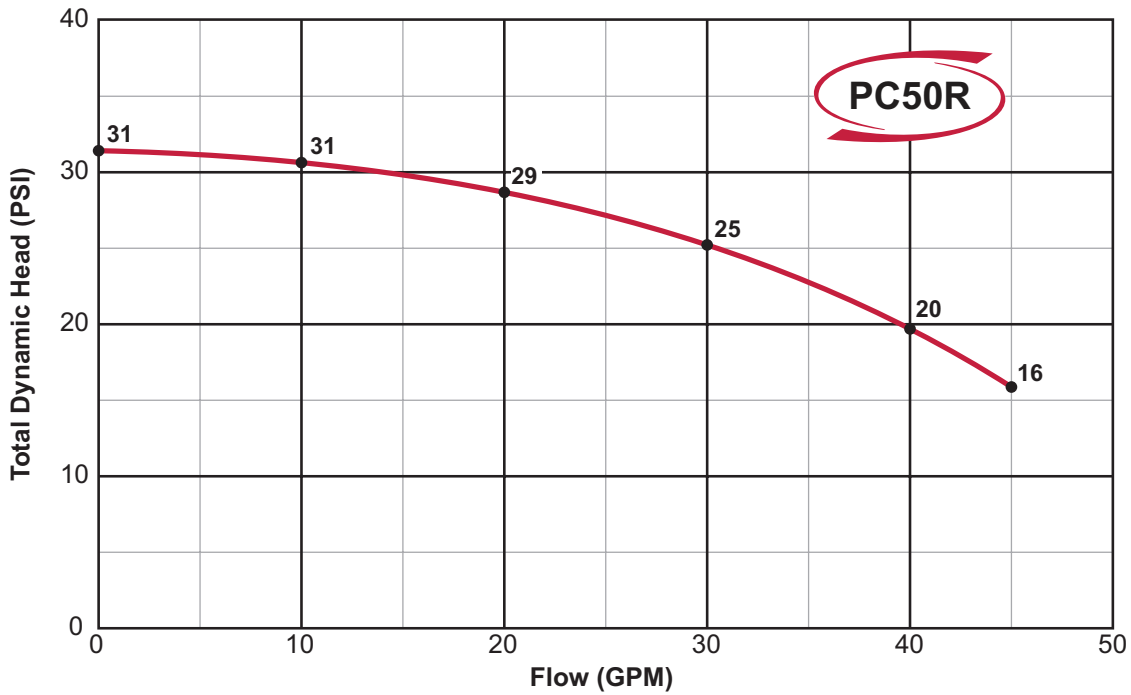
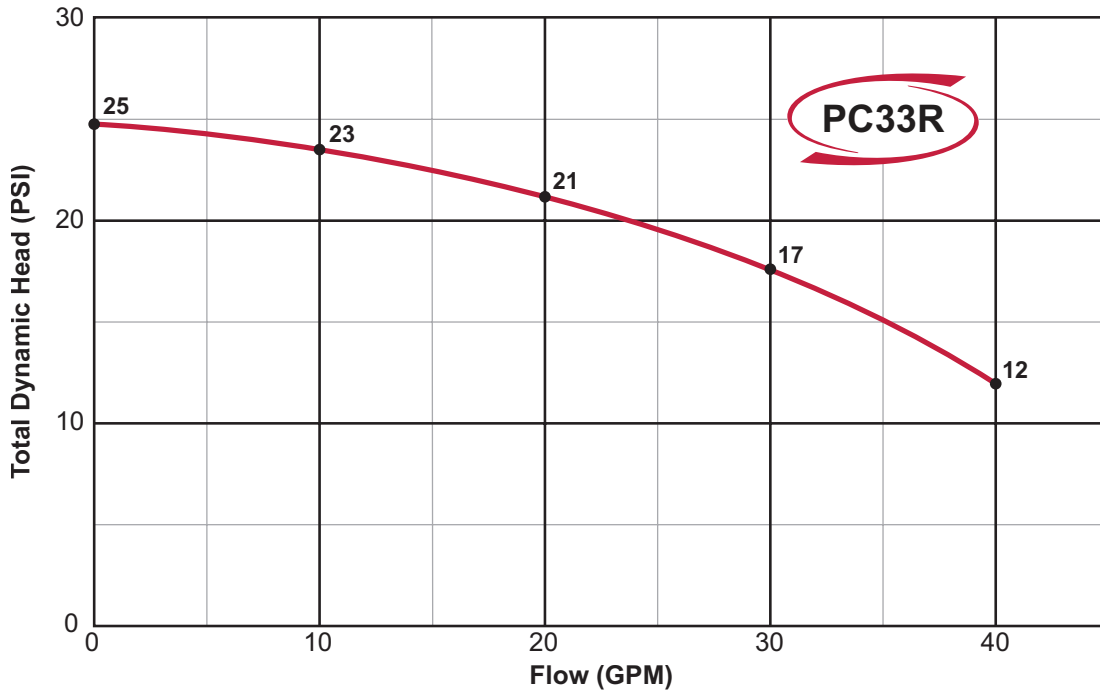



There when you need us most

**PC Series**

**PC SERIES GROUP CURVES**

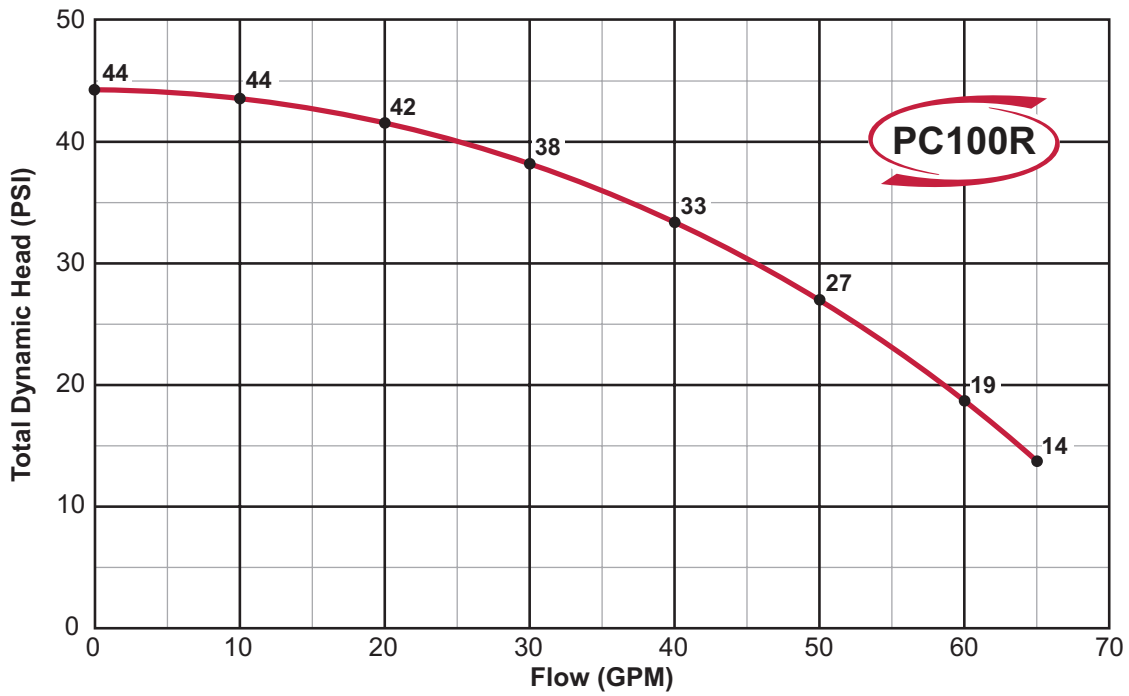
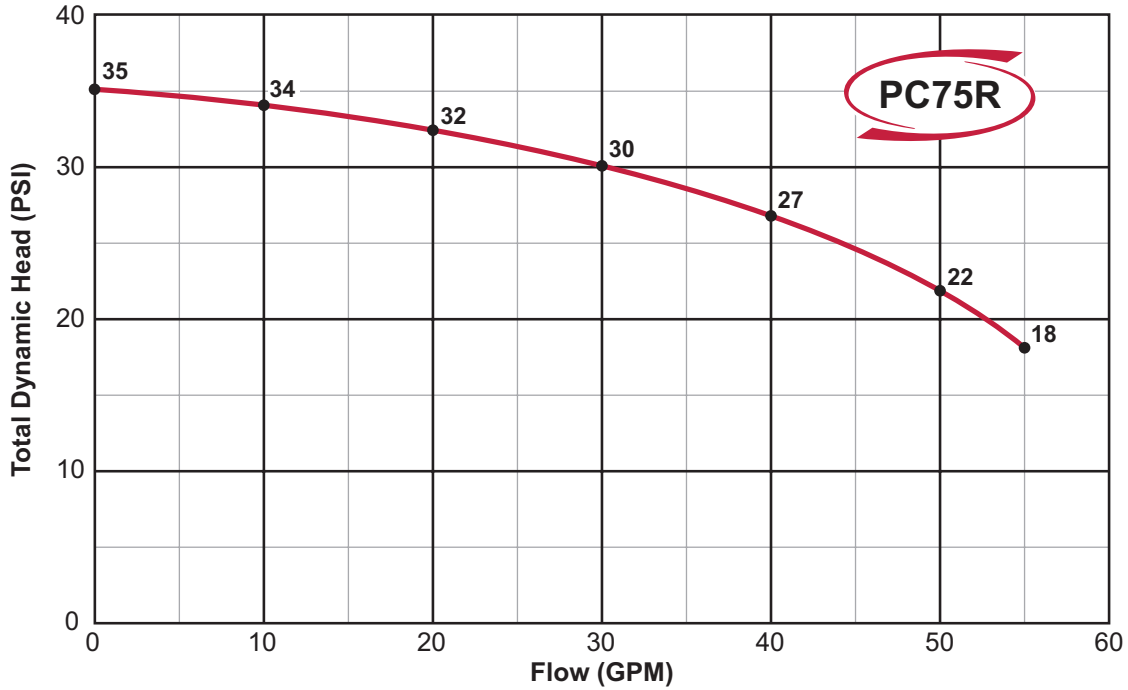

## PC SERIES GROUP CURVES

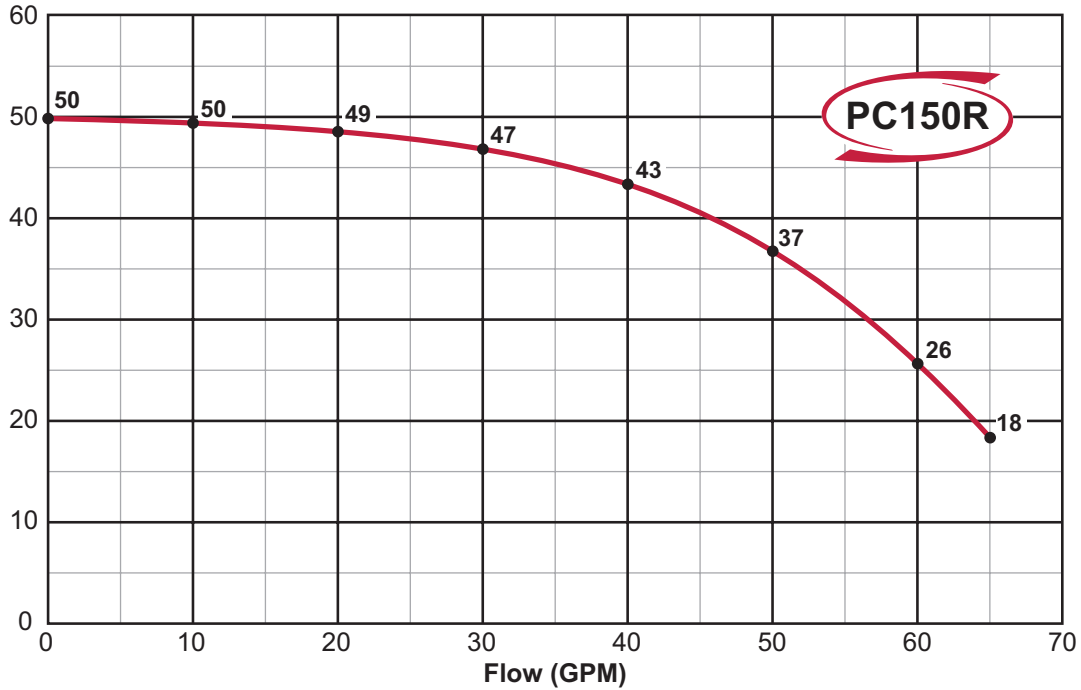

## PC Series

## PC SERIES CENTRIFUGAL Dimensions

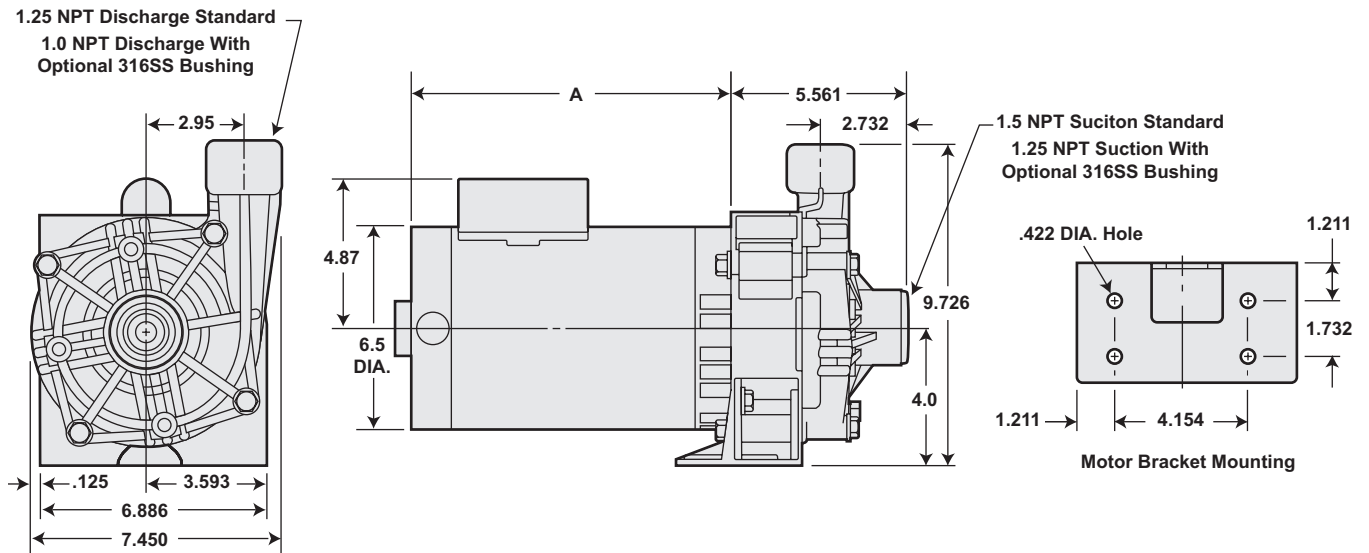

## Construction & Design Features

### .5 - 1.5 HP for Continuous Duty Operation

Model No.	A (Length)	HP
PC33R	8.51	.5
PC50R	8.51	.5
PC75R	9.36	.75
PC100R	9.36	1
PC150R	10.26	1.5

**Motor** - The end-mounting motor has no feet, and is supported by the motor bracket. An open drip-proof enclosure is standard with class B insulation.

CONSTRUCTION MATERIALS	
Part	Material
Pump Housing	Noryl®
Motor Bracket	Noryl®
Impeller (closed type)	Noryl®
Wear Ring	316 SS
Motor Shaft	303 SS
Mechanical Seal	Carbon/Ceramic
O-Rings	Viton™



## FC SERIES CENTRIFUGAL PUMPS

### Stainless Steel Centrifugal Pumps

#### **FC** Series

Dependable and rugged, FC Series pumps are corrosion and erosion resistant making them the logical choice for continuous duty service.

The quality and performance you expect, along with industry best lead times and personalized service, only from Webtrol!



#### Features and Benefits

- 304 stainless steel pump
- Close coupled design
- Centerline discharge
- Back pullout design allows for ease of servicing
- High operating efficiencies
- Mechanical seals and case o-rings are made of high quality materials

#### Performance

HP Range: 1 to 2, 60Hz - 1750 RPM  
3 to 30, 60Hz - 3450 RPM

Capacities to 600 GPM

Pressures to 120 PSI

Temperatures to 212 °F

#### Typical Services

- Pressure Boosting
- Ultrapure Water Systems
- Deionized Systems
- Distribution Systems
- Pharmaceutical Services
- Water Reclamation
- Sprinkler & Irrigation
- General Pump Applications
- Beverage Processing
- Parts Washers
- Cooling Towers
- Jockey Pump
- Liquid Transfer
- Heat Exchangers
- Car Wash
- Spray systems
- Scrubbers
- Poultry

## FC Series

## FC SERIES FAMILY CURVES

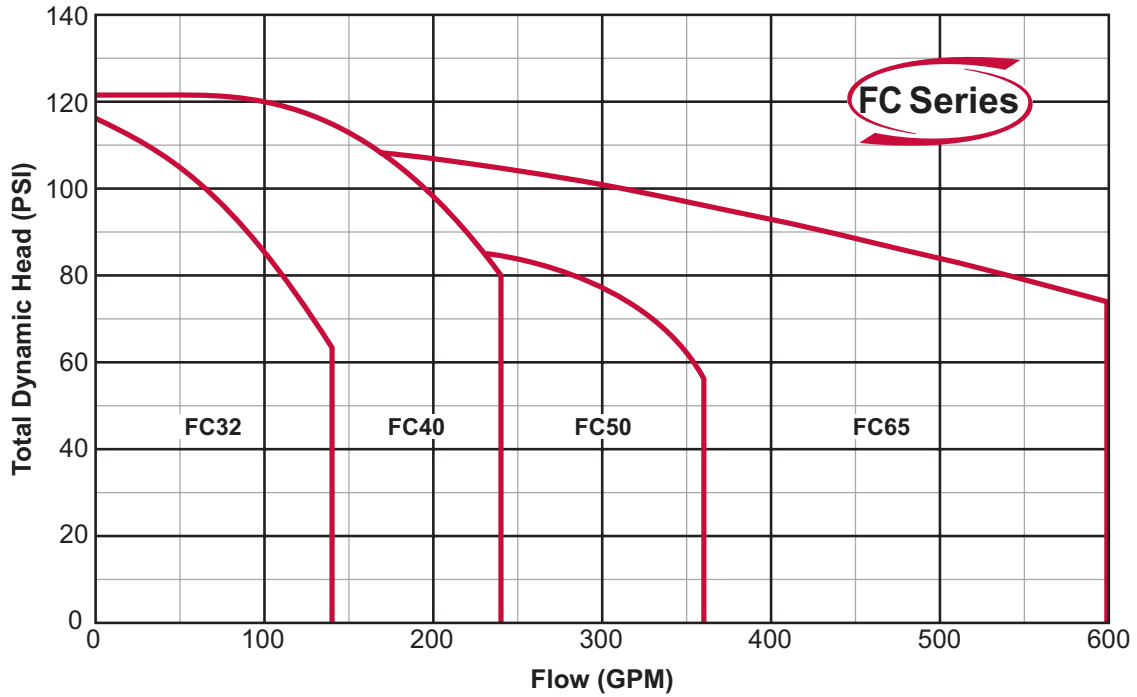

CONSTRUCTION MATERIALS	
Part	Material
Casing	304L SS
Impeller	304L SS
Shaft	SS
Mechanical Seal	Type 21



There when you need us most

## FC SERIES GROUP CURVES

**FC** Series

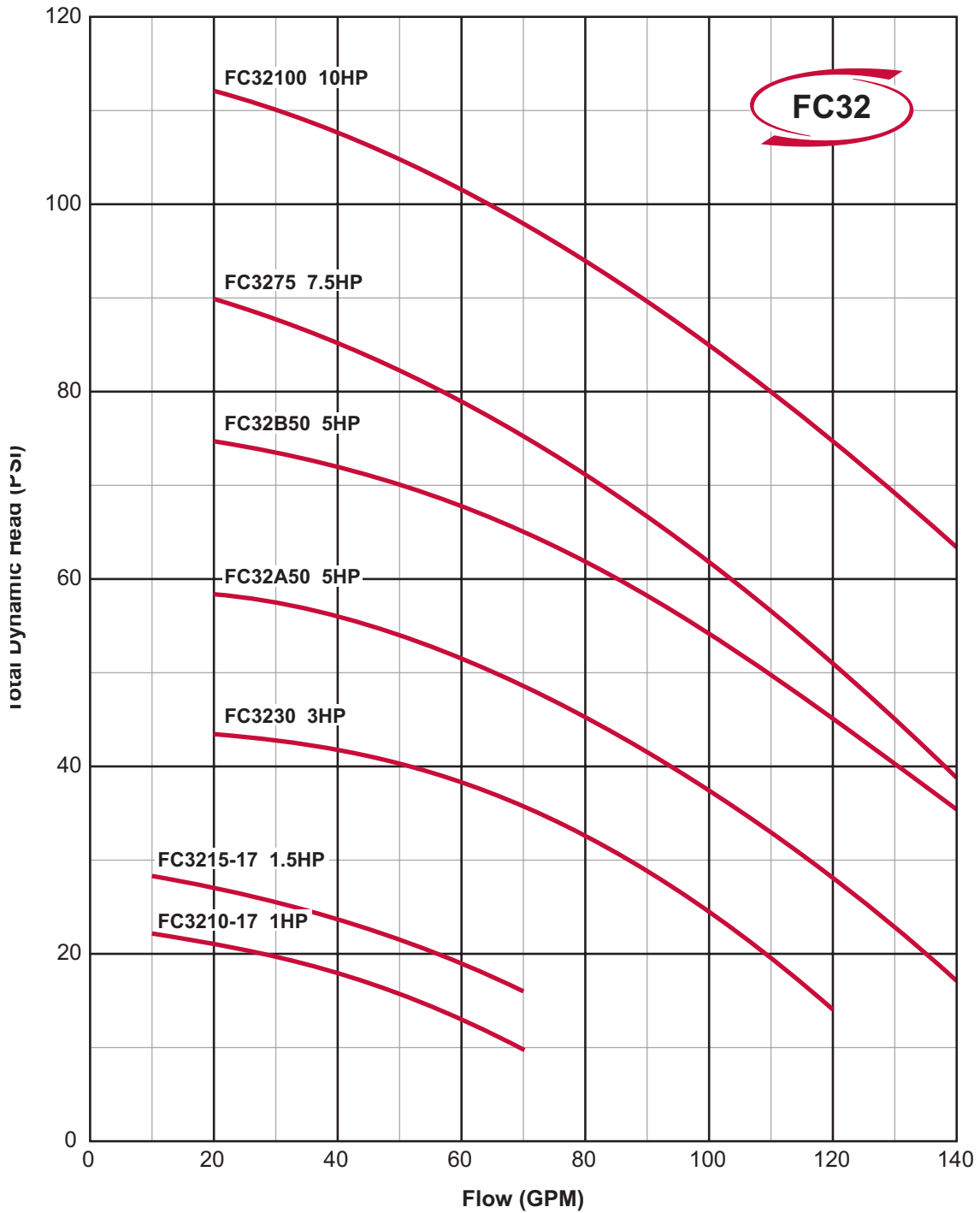



There when you need us most

**FC Series**

**FC SERIES GROUP CURVES**

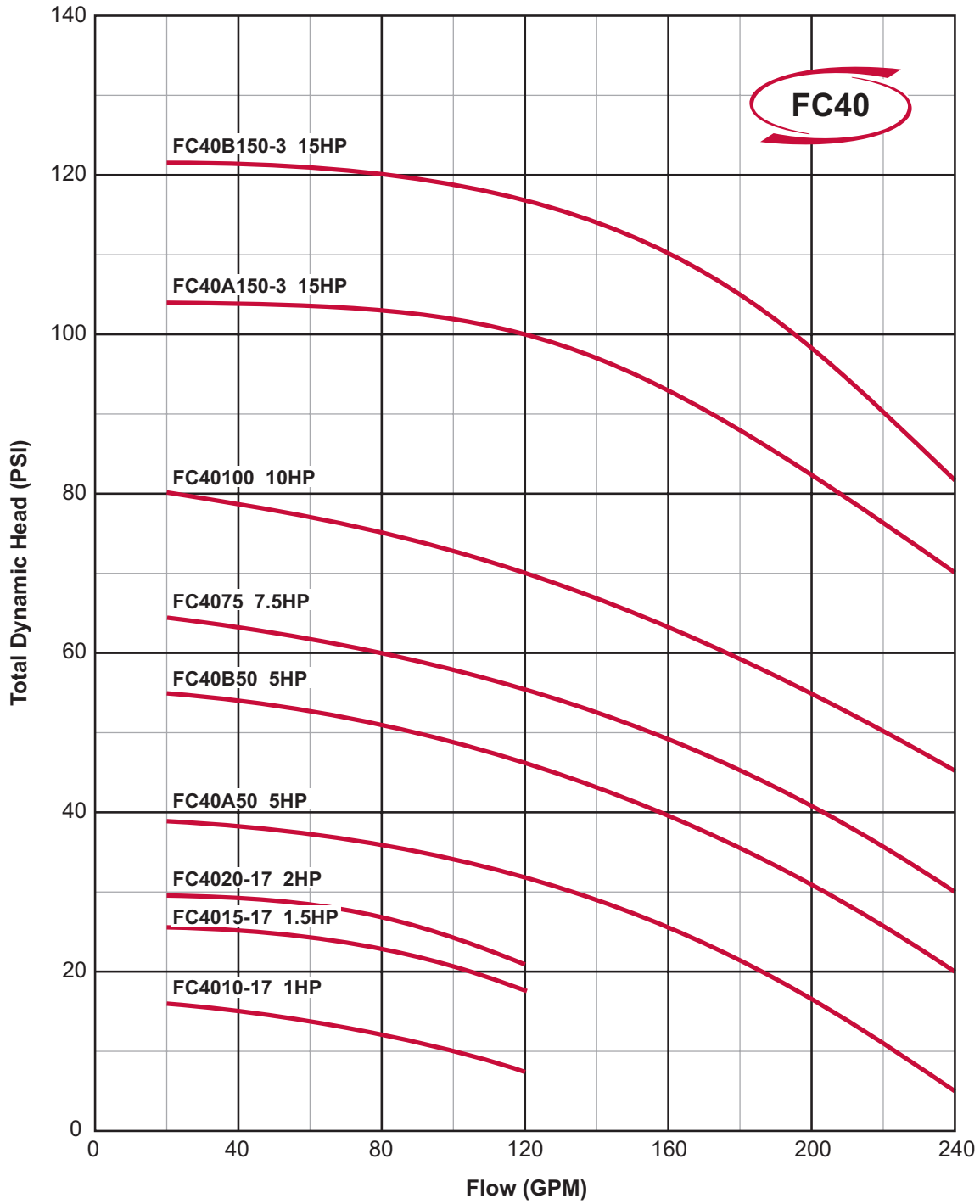



There when you need us most

## FC SERIES GROUP CURVES

**FC** Series

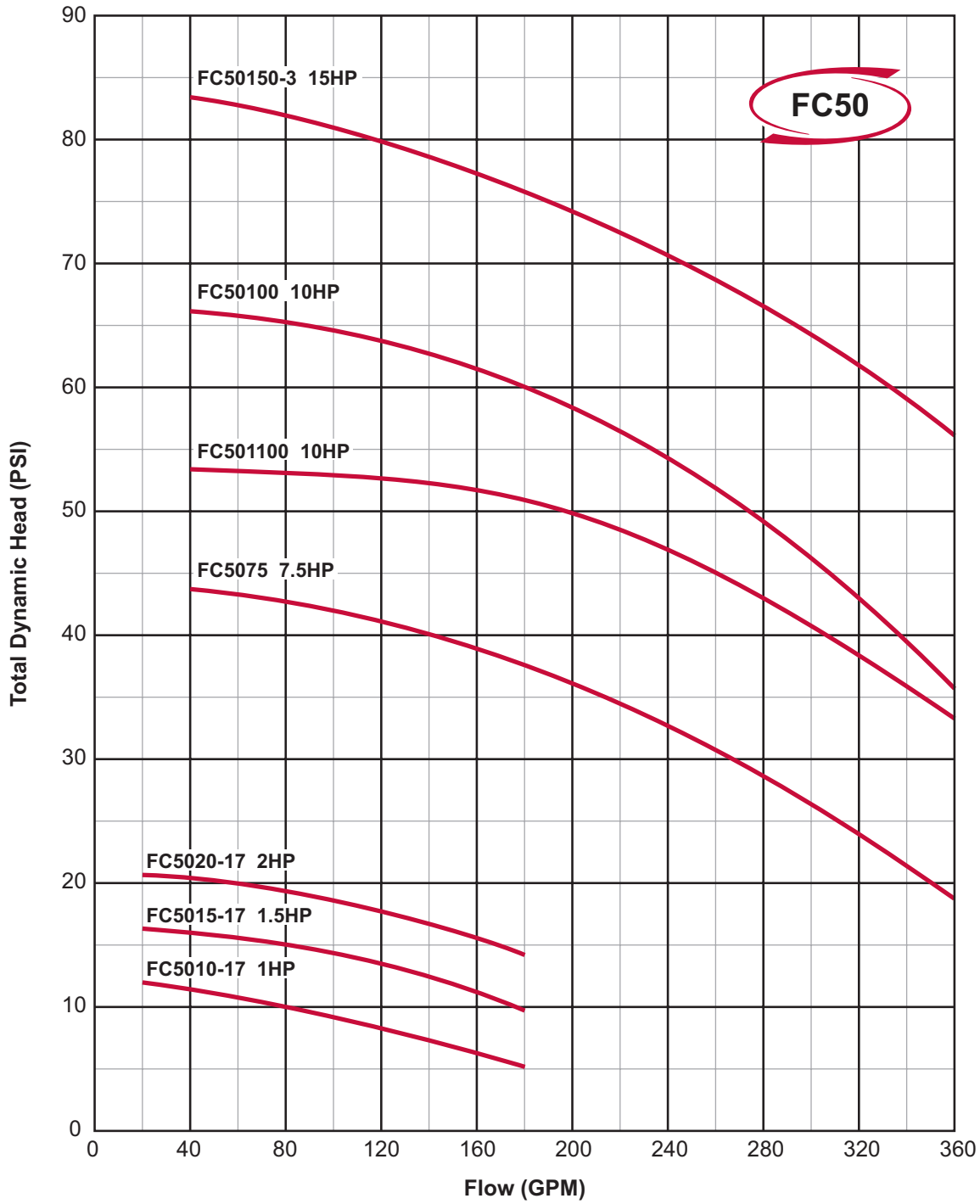

## FC Series

## FC SERIES GROUP CURVES

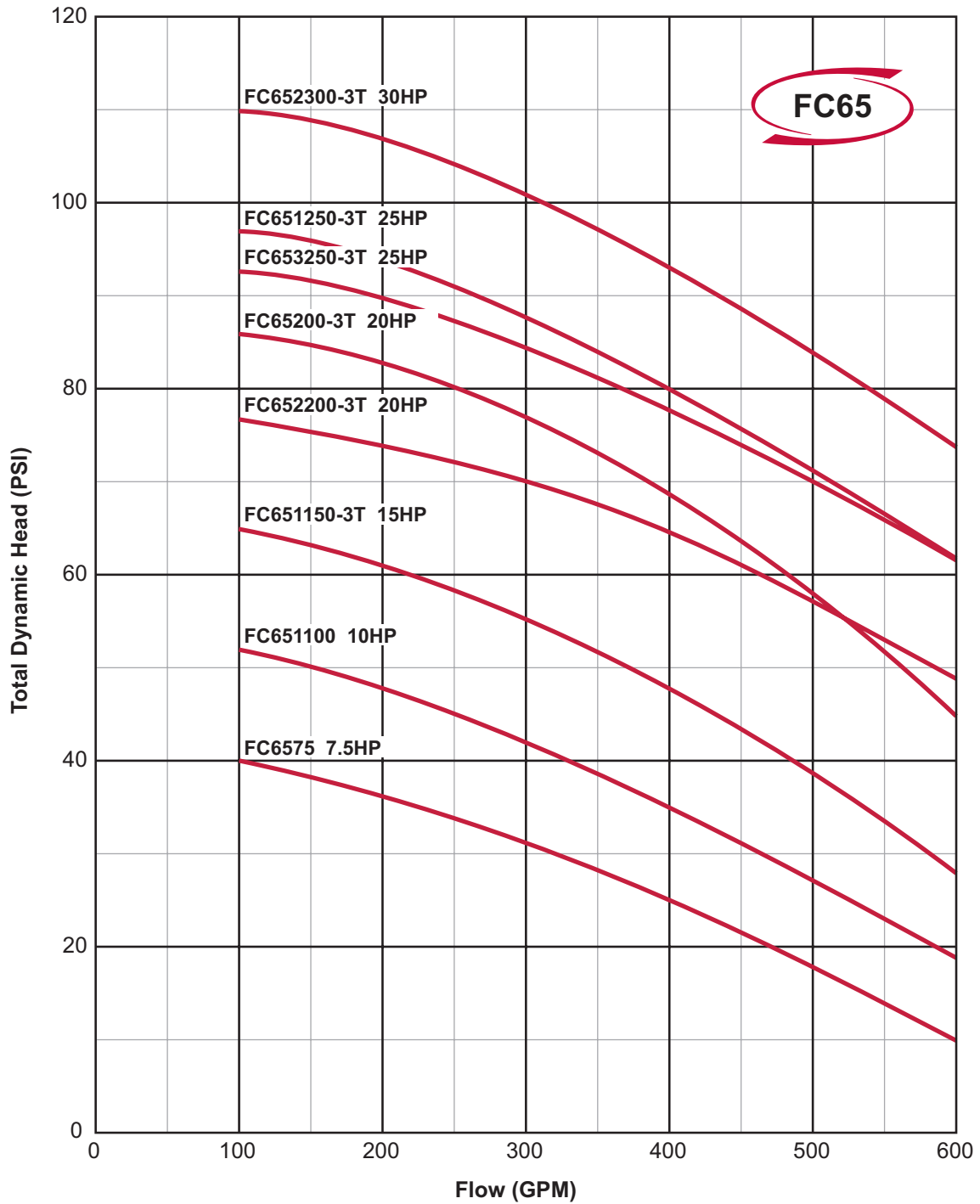

## FC SERIES CENTRIFUGAL Dimensions

**FC** Series

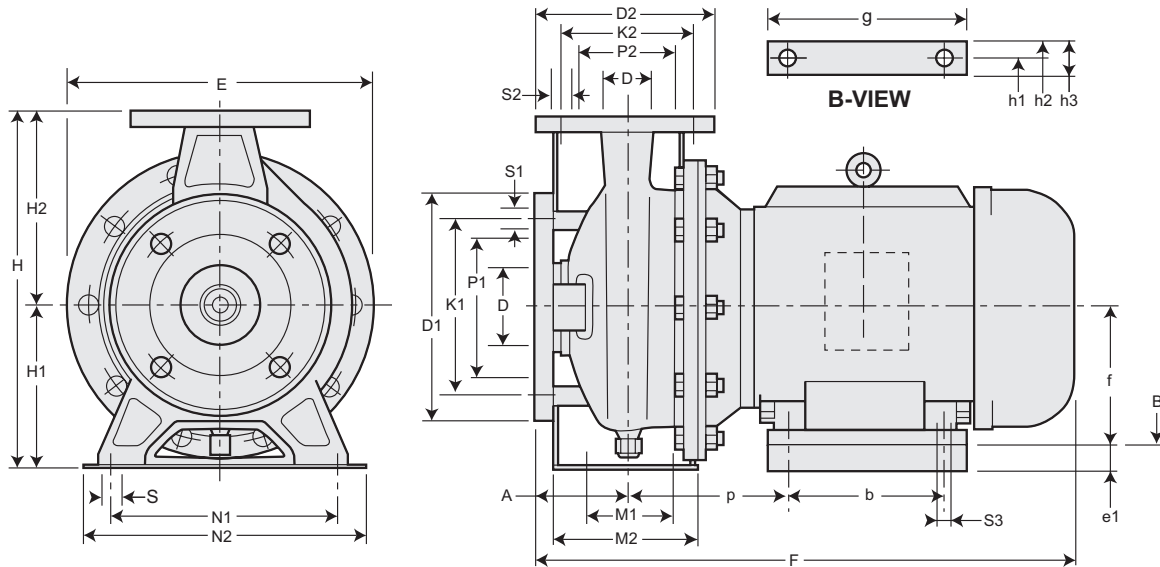

Model No.	Suction Flange (In.)					Discharge Flange (In.)				
	D	P1	K1	D1	S1	D	P2	K2	D2	S2
FC3230	2	3 3/4	4 15/16	6 1/2	11/16	1 1/4	2 1/2	3 1/2	5 1/2	5/8
FC32A50	2	3 3/4	4 15/16	6 1/2	11/16	1 1/4	2 1/2	3 1/2	5 1/2	5/8
FC32B50	2	3 3/4	4 15/16	6 1/2	11/16	1 1/4	2 1/2	3 1/2	5 1/2	5/8
FC3275	2	3 3/4	4 15/16	6 1/2	11/16	1 1/4	2 1/2	3 1/2	5 1/2	5/8
FC32100	2	3 3/4	4 15/16	6 1/2	11/16	1 1/4	2 1/2	3 1/2	5 1/2	5/8
FC40A50	2 1/2	4 9/16	5 11/16	7 5/16	11/16	1 1/2	2 7/8	3 7/8	5 7/8	5/8
FC40B50	2 1/2	4 9/16	5 11/16	7 5/16	11/16	1 1/2	2 7/8	3 7/8	5 7/8	5/8
FC4075	2 1/2	4 9/16	5 11/16	7 5/16	11/16	1 1/2	2 7/8	3 7/8	5 7/8	5/8
FC40100	2 1/2	4 9/16	5 11/16	7 5/16	11/16	1 1/2	2 7/8	3 7/8	5 7/8	5/8
FC40A150-3	2 1/2	4 9/16	5 11/16	7 5/16	11/16	1 1/2	2 7/8	3 7/8	5 7/8	5/8
FC40B150-3	2 1/2	4 9/16	5 11/16	7 5/16	11/16	1 1/2	2 7/8	3 7/8	5 7/8	5/8
FC5075	2 1/2	4 9/16	5 11/16	7 5/16	11/16	2	3 3/4	4 15/16	6 1/2	11/16
FC501100	2 1/2	4 9/16	5 11/16	7 5/16	11/16	2	3 3/4	4 15/16	6 1/2	11/16
FC50100	2 1/2	4 9/16	5 11/16	7 5/16	11/16	2	3 3/4	4 15/16	6 1/2	11/16
FC50150-3	2 1/2	4 9/16	5 11/16	7 5/16	11/16	2	3 3/4	4 15/16	6 1/2	11/16

## FC Series

## FC SERIES CENTRIFUGAL Pump Dimensions

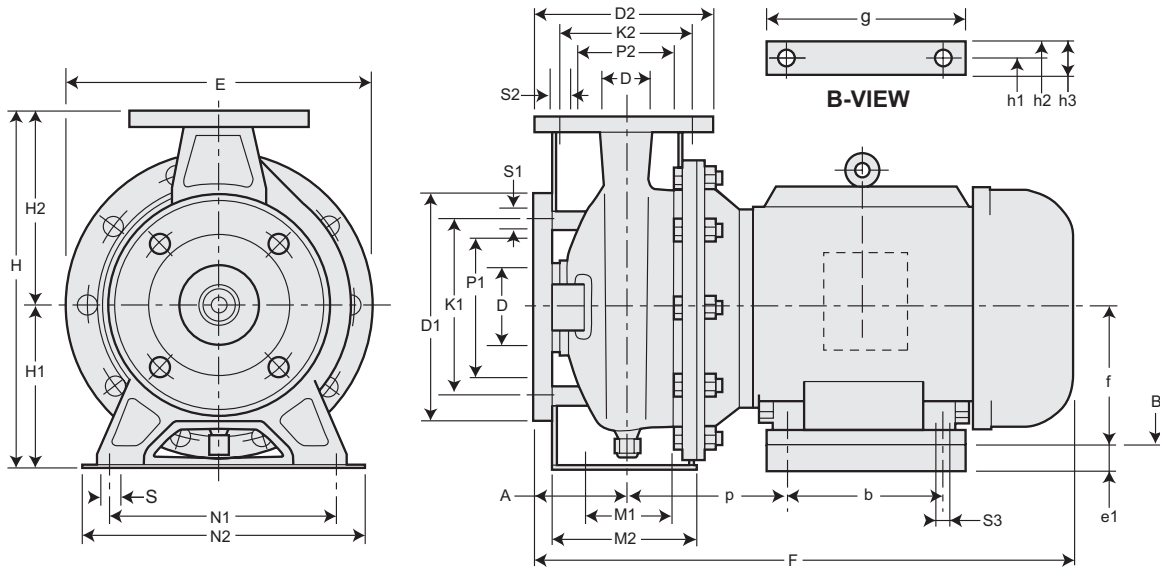

Model No.	Pump Dimensions (in.)									
	A	E	H	H1	H2	M1	M2	N1	N2	S
FC3230	3 1/8	8 3/8	9 15/16	4 7/16	5 1/2	2 3/4	4 1/2	5 1/2	7 1/2	9/16
FC32A50	3 1/8	10	11 1/2	5 3/16	6 5/16	2 3/4	4 5/8	7 1/2	9 7/16	9/16
FC32B50	3 1/8	10	11 1/2	5 3/16	6 5/16	2 3/4	4 5/8	7 1/2	9 7/16	9/16
FC3275	3 1/8	1 9/16	13 3/8	6 5/16	7 1/16	2 3/4	4 11/16	7 1/2	9 7/16	9/16
FC32100	3 1/8	1 9/16	13 3/8	6 5/16	7 1/16	2 3/4	4 11/16	7 1/2	9 7/16	9/16
FC40A50	3 1/8	8 3/8	9 15/16	4 7/16	5 1/2	2 3/4	4 1/2	6 5/16	8 1/4	9/16
FC40B50	3 1/8	8 3/8	9 15/16	4 7/16	5 1/2	2 3/4	4 1/2	6 5/16	8 1/4	9/16
FC4075	3 1/8	10	11 1/2	5 3/16	6 5/16	2 3/4	4 5/8	7 1/2	9 7/16	9/16
FC40100	3 1/8	10	11 1/2	5 3/16	6 5/16	2 3/4	4 5/8	7 1/2	9 7/16	9/16
FC40A150-3	3 15/16	1 9/16	13 3/8	6 5/16	7 1/16	2 3/4	4 1/2	8 3/8	10 7/16	9/16
FC40B150-3	3 15/16	1 9/16	13 3/8	6 5/16	7 1/16	2 3/4	4 1/2	8 3/8	10 7/16	9/16
FC5075	3 15/16	10	11 1/2	5 3/16	6 5/16	2 3/4	4 1/2	7 1/2	9 7/16	9/16
FC501100	3 15/16	10	11 1/2	5 3/16	6 5/16	2 3/4	4 1/2	7 1/2	9 7/16	9/16
FC50100	3 15/16	1 11/16	13 3/8	6 5/16	7 1/16	2 3/4	4 1/2	8 3/8	10 7/16	9/16
FC50150-3	3 15/16	1 11/16	13 3/8	6 5/16	7 1/16	2 3/4	4 1/2	8 3/8	10 7/16	9/16





There when you need us most

## FC SERIES CENTRIFUGAL Motor Dimensions

**FC** Series

Model No.	NEMA Frame	Motor Dimensions (in.)									
		b	e1	f	g	h1	h2	h3	p	S3	F
FC3230	145JM	5	15/16	3 1/2	5 15/16	5 1/2	6 1/2	1	6 9/16	11/32	18 15/16
FC3230	182JM	4 1/2	-1/16	4 1/2	6 1/2	7 1/2	8 1/2	1	7 3/16	13/32	19 3/16
FC32A50	182JM	4 1/2	11/16	4 1/2	6 1/2	7 1/2	8 1/2	1	7 3/16	13/32	19 3/16
FC32A50	184JM	5 1/2	11/16	4 1/2	6 1/2	7 1/2	8 1/2	1	7 3/16	13/32	20 5/8
FC32B50	182JM	4 1/2	11/16	4 1/2	6 1/2	7 1/2	8 1/2	1	7 3/16	13/32	19 3/16
FC32B50	184JM	5 1/2	11/16	4 1/2	6 1/2	7 1/2	8 1/2	1	7 3/16	13/32	20 5/8
FC3275	184JM	5 1/2	1 13/16	4 1/2	6 1/2	7 1/2	8 1/2	1	7 3/16	13/32	22 1/8
FC3275	213JM	5 1/2	1 1/16	5 1/4	8	8 1/2	9 1/2	1	8 3/16	13/32	20 3/4
FC32100	213JM	5 1/2	1 1/16	5 1/4	8	8 1/2	9 1/2	1	8 3/16	13/32	20 3/4
FC32100	215JM	7	1 1/16	5 1/4	8	8 1/2	9 1/2	1	8 3/16	13/32	21 7/8
FC40A50	182JM	4 1/2	-1/16	4 1/2	6 1/2	7 1/2	8 1/2	1	7 3/16	13/32	19 3/16
FC40A50	184JM	5 1/2	-1/16	4 1/2	6 1/2	7 1/2	8 1/2	1	7 3/16	13/32	20 3/4
FC40B50	182JM	4 1/2	-1/16	4 1/2	6 1/2	7 1/2	8 1/2	1	7 3/16	13/32	19 3/16
FC40B50	184JM	5 1/2	-1/16	4 1/2	6 1/2	7 1/2	8 1/2	1	7 3/16	13/32	20 3/4
FC4075	184JM	5 1/2	11/16	4 1/2	6 1/2	7 1/2	8 1/2	1	7 3/16	13/32	22 1/8
FC4075	213JM	5 1/2	-1/16	5 1/4	8	8 1/2	9 1/2	1	8 3/16	13/32	20 3/4
FC40100	213JM	5 1/2	-1/16	5 1/4	8	8 1/2	9 1/2	1	8 3/16	13/32	20 3/4
FC40100	215JM	7	-1/16	5 1/4	8	8 1/2	9 1/2	1	8 3/16	13/32	21 7/8
FC40A150-3	215JM	7	1 1/16	5 1/4	8	8 1/2	9 1/2	1	8 3/16	13/32	22 11/16
FC40B150-3	215JM	7	1 1/16	5 1/4	8	8 1/2	9 1/2	1	8 3/16	13/32	22 11/16
FC5075	184JM	5 1/2	11/16	4 1/2	6 1/2	7 1/2	8 1/2	1	7 3/16	13/32	22 15/16
FC5075	213JM	5 1/2	-1/16	5 1/4	8	8 1/2	9 1/2	1	8 3/16	13/32	21 9/16
FC501100	213JM	5 1/2	-1/16	5 1/4	8	8 1/2	9 1/2	1	8 3/16	13/32	21 9/16
FC501100	215JM	7	-1/16	5 1/4	8	8 1/2	9 1/2	1	8 3/16	13/32	22 11/16
FC50100	213JM	5 1/2	1 1/16	5 1/4	8	8 1/2	9 1/2	1	8 3/16	13/32	21 9/16
FC50100	215JM	7	1 1/16	5 1/4	8	8 1/2	9 1/2	1	8 3/16	13/32	22 11/16
FC50150-3	215JM	7	1 1/16	5 1/4	8	8 1/2	9 1/2	1	8 3/16	13/32	22 11/16

## FC Series

## FC SERIES CENTRIFUGAL Pump and Motor Dimensions

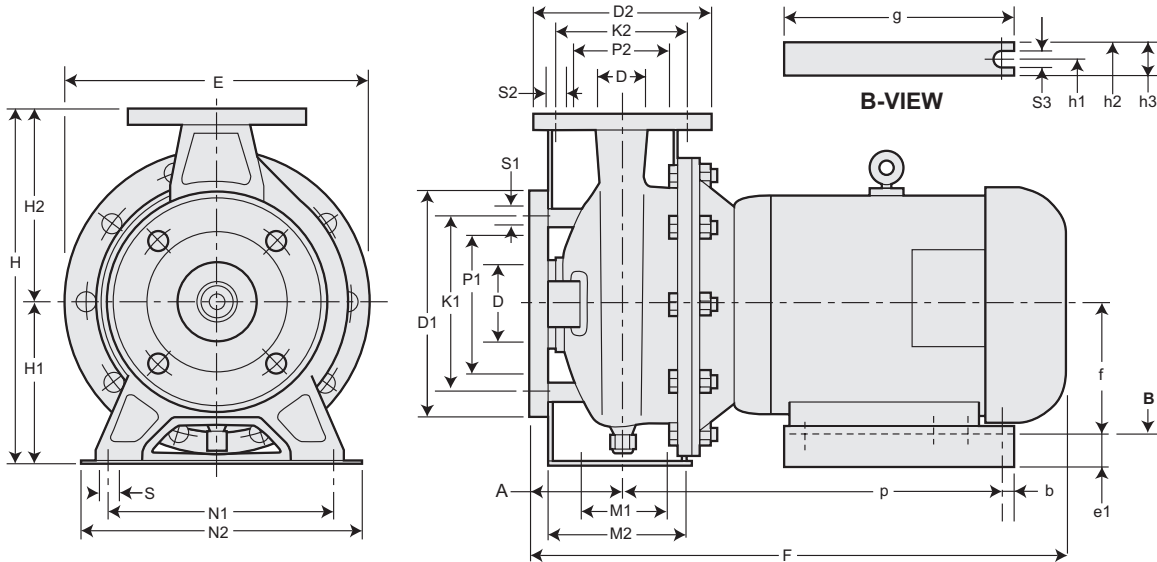

Model No.	Suction Flange (in.)					Discharge Flange (in.)				
	D	P1	K1	D1	S1	D	P2	K2	D2	S2
FC6575	3 3/16	5 1/4	6	7 7/8	11/16	2 9/16	4 1/2	5 11/16	7 5/16	11/16
FC651100	3 3/16	5 1/4	6	7 7/8	11/16	2 9/16	4 1/2	5 11/16	7 5/16	11/16
FC651150-3	3 3/16	5 1/4	6	7 7/8	11/16	2 9/16	4 1/2	5 11/16	7 5/16	11/16

Model No.	Pump Dimensions (in.)									
	A	E	H	H1	H2	M1	M2	N1	N2	S
FC6575	3 15/16	10	13 3/8	6 5/16	7 1/16	3 3/4	5 1/2	8 3/8	11	9/16
FC651100	3 15/16	10	13 3/8	6 5/16	7 1/16	3 3/4	5 1/2	8 3/8	11	9/16
FC651150-3	3 15/16	11 5/8	14 3/16	6 5/16	7 7/8	3 3/4	5 1/2	8 3/8	11	9/16

Model No.	NEMA Frame	Motor Dimensions (in.)									
		b	e1	f	g	h1	h2	h3	p	S3	F
FC6575	213JM	9/16	1 1/16	5 1/4	9 9/16	8 1/2	10 1/4	1 3/4	16 9/16	1/2	23 3/16
FC651100	215JM	9/16	1 1/16	5 1/4	9 9/16	8 1/2	10 1/4	1 3/4	16 9/16	1/2	23 3/16
FC651150-3	215JM	9/16	1 1/16	5 1/4	9 9/16	8 1/2	10 1/4	1 3/4	16 9/16	1/2	23 3/16

## FC SERIES CENTRIFUGAL Pump and Motor Dimensions

**FC** Series

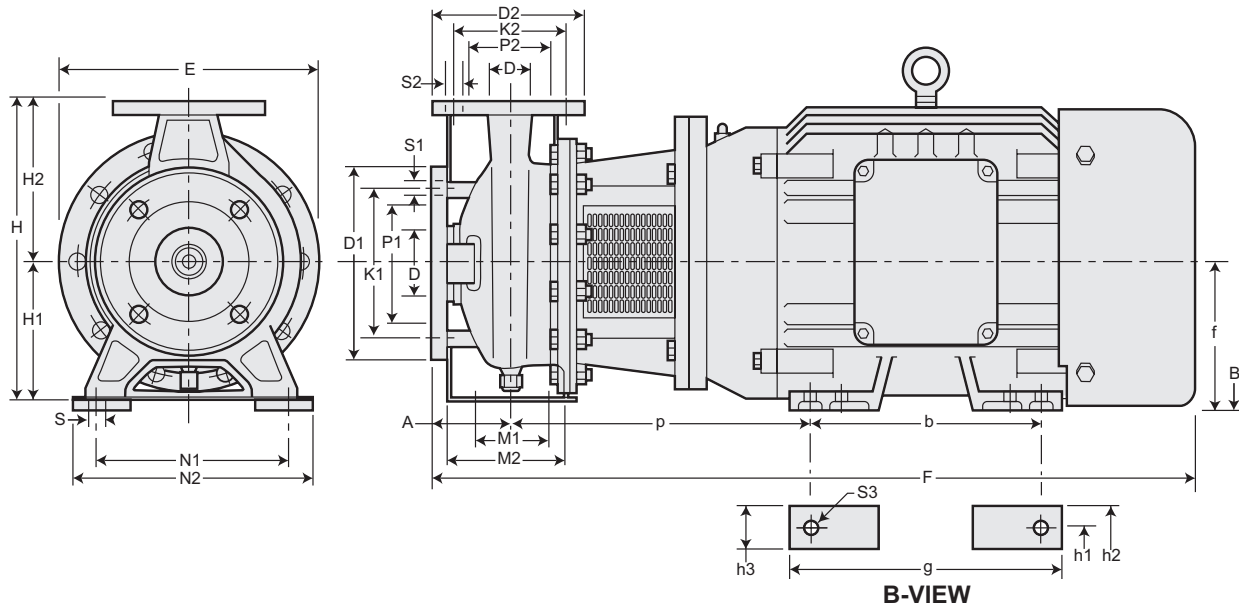

Model No.	Suction Flange (in.)					Discharge Flange (in.)				
	D	P1	K1	D1	S1	D	P2	K2	D2	S2
FC652200-3T	3 3/16	5 1/4	6	7 7/8	11/16	2 9/16	4 1/2	5 11/16	7 5/16	11/16
FC65200-3T	3 3/16	5 1/4	6	7 7/8	11/16	2 9/16	4 1/2	5 11/16	7 5/16	11/16
FC653250-3T	3 3/16	5 1/4	6	7 7/8	11/16	2 9/16	4 1/2	5 11/16	7 5/16	11/16
FC651250-3T	3 3/16	5 1/4	6	7 7/8	11/16	2 9/16	4 1/2	5 11/16	7 5/16	11/16
FC652300-3T	3 3/16	5 1/4	6	7 7/8	11/16	2 9/16	4 1/2	5 11/16	7 5/16	11/16

Pump Dimensions in.)									
A	E	H	H1	H2	M1	M2	N1	N2	S
3 15/16	11 5/8	14 3/16	6 5/16	7 7/8	3 3/4	5 1/2	8 3/8	11	9/16
3 15/16	11 5/8	15 15/16	7 1/16	8 7/8	3 3/4	5 1/2	9 13/16	12 5/8	9/16
3 15/16	11 5/8	14 7/8	6 5/16	7 7/8	3 3/4	4 15/16	8 3/8	11 1/8	9/16
3 15/16	11 5/8	15 15/16	7 1/16	8 7/8	3 3/4	5 1/2	9 13/16	12 5/8	9/16
3 15/16	11 5/8	15 15/16	7 1/16	8 7/8	3 3/4	5 1/2	9 13/16	12 5/8	9/16

Model No.	NEMA Frame	Motor Dimensions (in.)								
		b	f	g	h1	h2	h3	p	S3	F
FC652200-3T	256TC	10	6 1/4	11 5/8	10	12 3/8	2 3/8	13 13/16	17/32	32 3/8
FC65200-3T	256TC	10	6 1/4	13 9/16	10	12 3/8	2 3/8	25 13/16	17/32	32 3/8
FC653250-3T	284TSC	11	7	12 13/16	11	12 3/4	-	13 7/8	17/32	36
FC651250-3T	284TSC	11	7	13	11	12 15/16	1 15/16	13 7/8	17/32	36
FC652300-3T	286TSC	11	7	13	11	12 15/16	1 15/16	13 7/8	17/32	36



## TC SERIES CENTRIFUGAL PUMPS

### Stainless Steel Centrifugal Pumps

#### **TC** Series

The rugged TC Series pumps are corrosion and erosion resistant making them a dependable choice for continuous duty service.

The quality and performance you expect, along with industry best lead times and personalized service, only from Webtrol!



#### **Features and Benefits**

- 304 stainless steel pump
- Close coupled design
- Centerline discharge
- Back pullout design allows for ease of servicing
- High operating efficiencies
- Mechanical seals and case o-rings are made of high quality materials

#### **Performance**

HP Range: .5 to 3 HP, 60Hz

Capacities to 100 GPM

Pressures to 63 PSI

Temperatures to 212 °F

#### **Typical Services**

- Pressure Boosting
- Ultrapure Water Systems
- Deionized Systems
- Distribution Systems
- Pharmaceutical Services
- Water Reclamation
- Sprinkler & Irrigation
- General Pump Applications
- Beverage Processing
- Parts Washers
- Cooling Towers
- Jockey Pump
- Liquid Transfer
- Heat Exchangers
- Car Wash
- Spray systems
- Scrubbers
- Poultry

## TC Series

## TC SERIES FAMILY CURVES

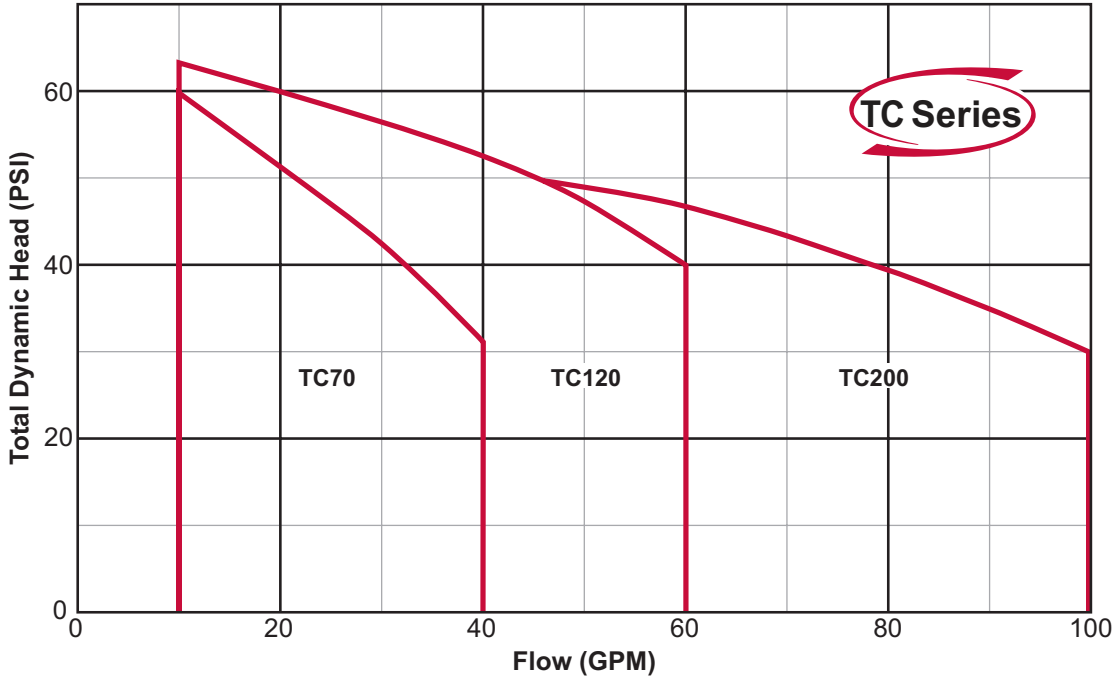

CONSTRUCTION MATERIALS	
Part	Material
Casing	304 SS
Impeller	304 SS
Shaft	Stainless
Mechanical Seal	Carbon/Ceramic Viton™



There when you need us most

## TC SERIES GROUP CURVES

**TC** Series

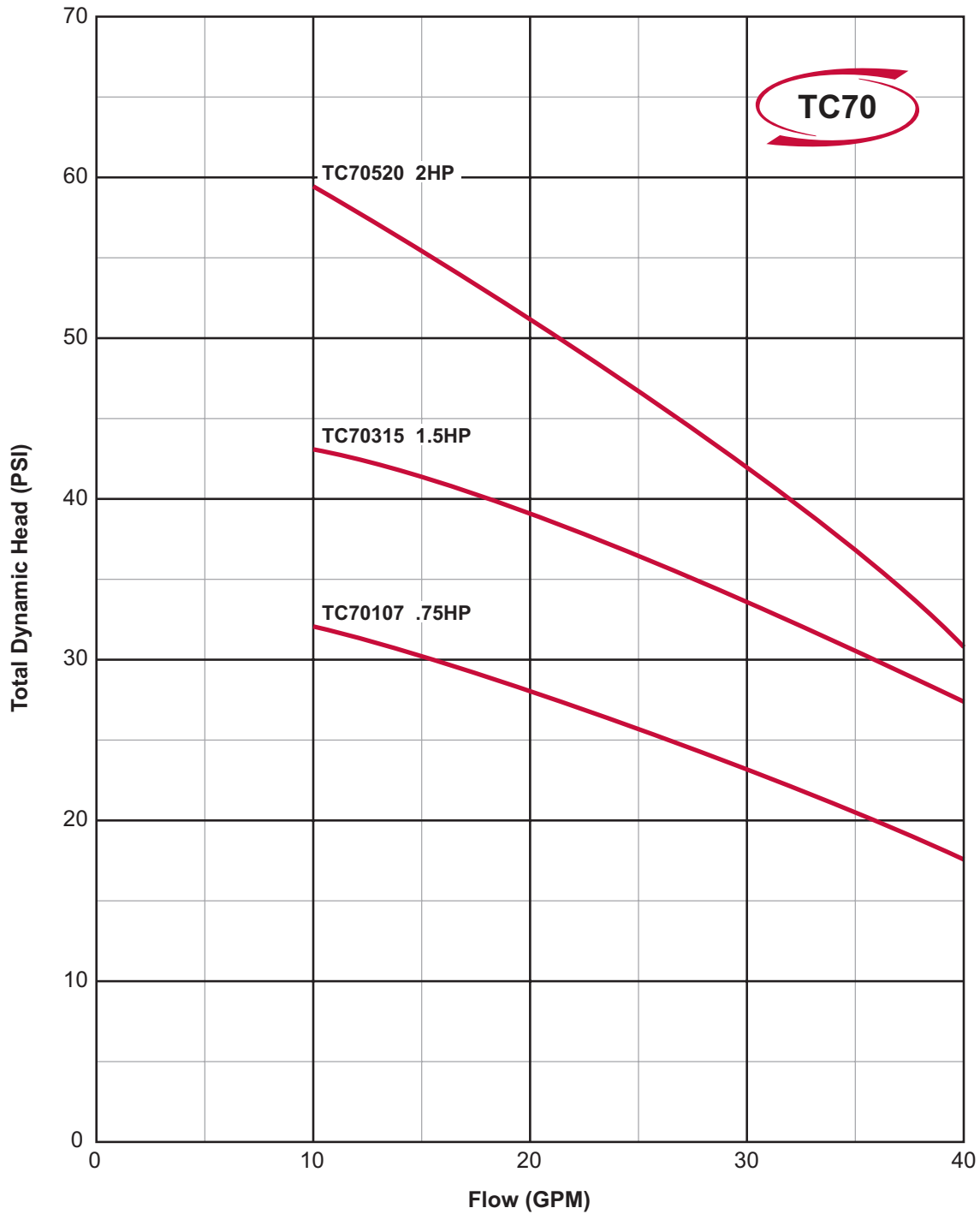

## TC Series

## TC SERIES GROUP CURVES

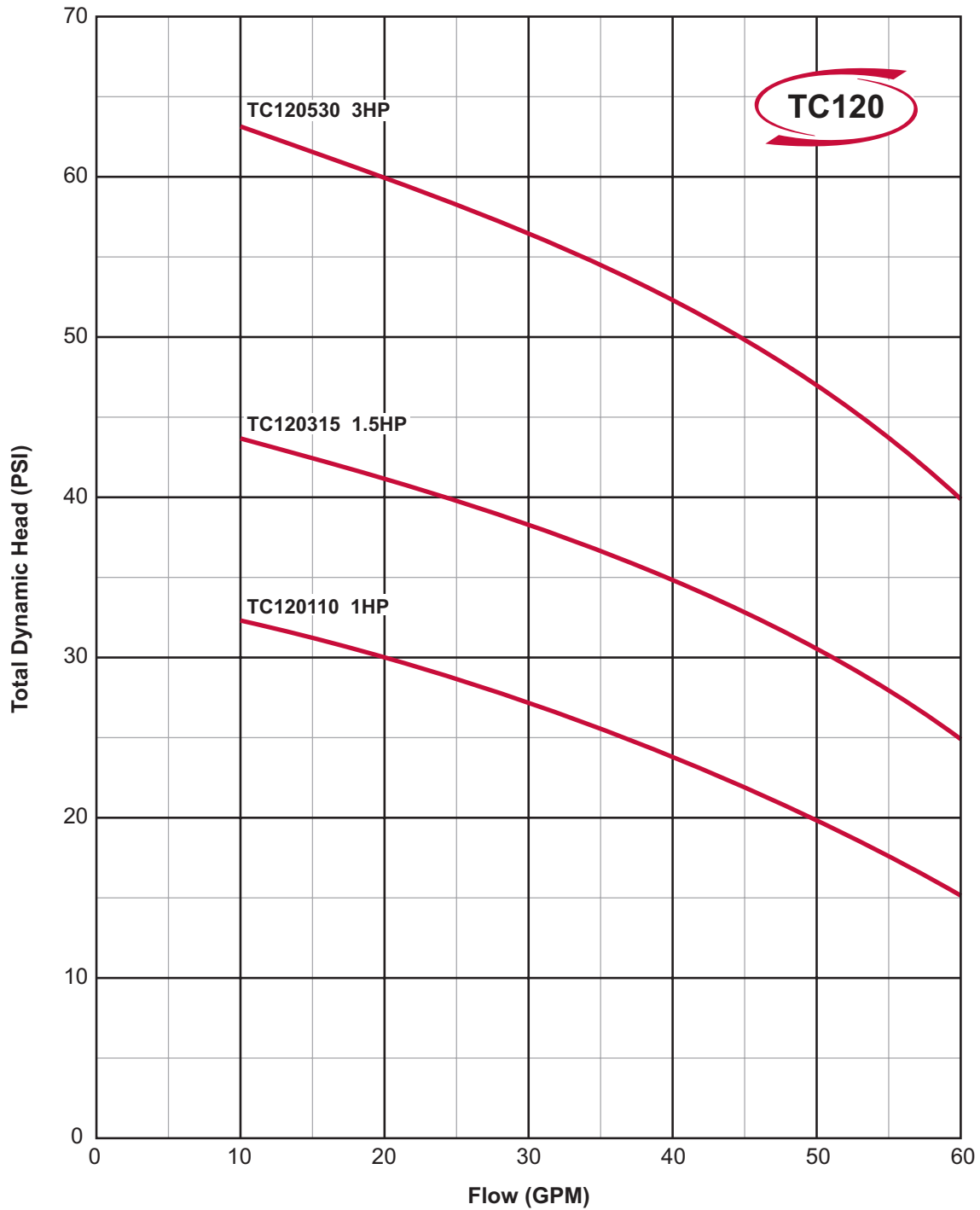





There when you need us most

## TC SERIES GROUP CURVES

**TC** Series

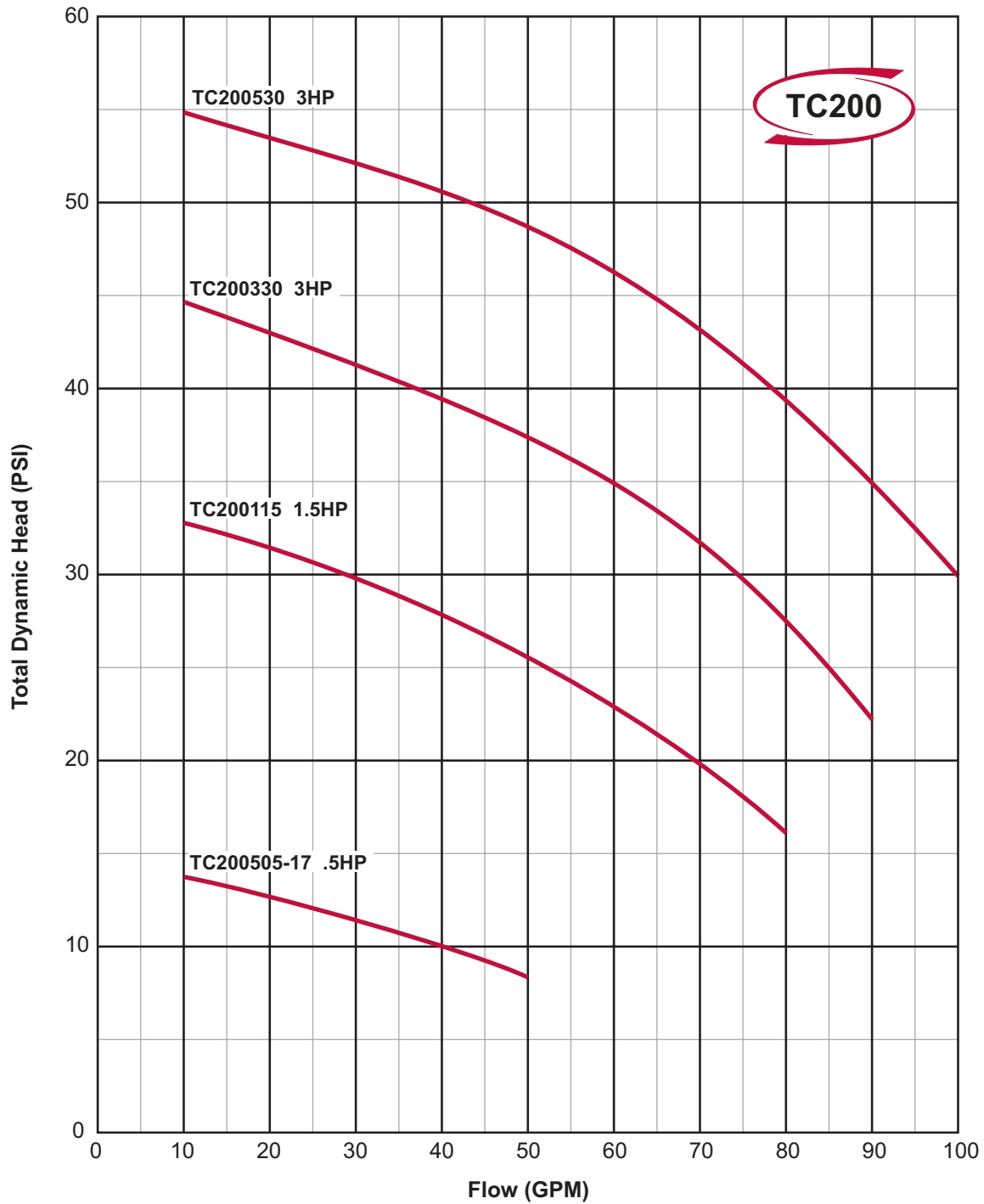

## TC Series

## TC SERIES CENTRIFUGAL Pump and Motor Dimensions

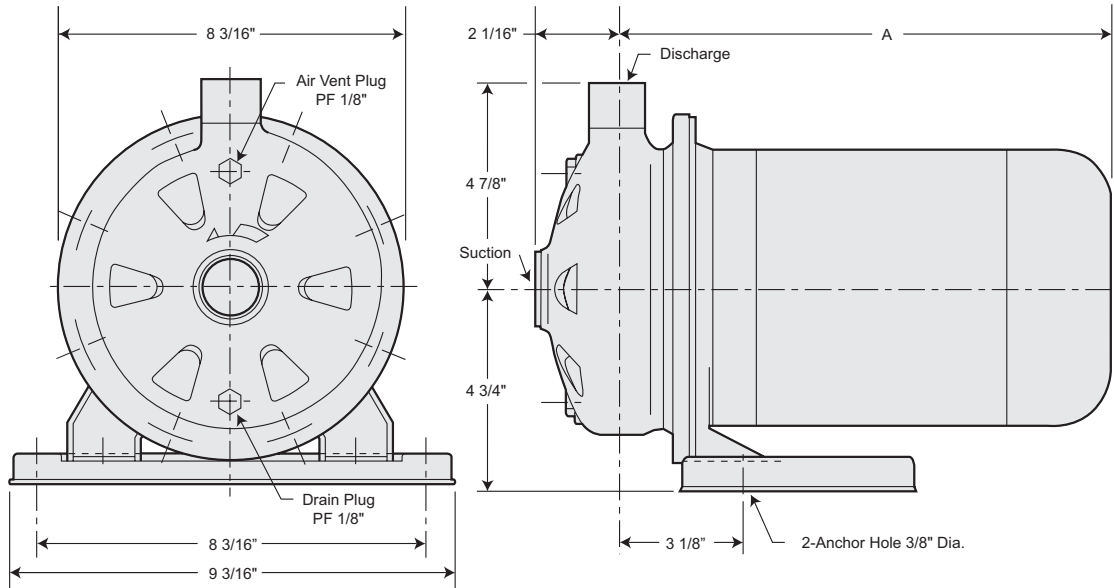

Model No.	Discharge / Suction/Imp. (inch-NPTF)	"A" Dimension	Single Phase Unit Weight (lbs.)		Three Phase Unit Weight (lbs.)	
			ODP	TEFC	ODP	TEFC
TC70107	1" x 1.25" x 4.5"	13.125"	36	41	31	31
TC70315	1" x 1.25" x 5.1875"	13.5625"	47	50	39	39
TC70520	1" x 1.25" x 6.1875"	14.4375"	51	58	44	48
TC120110	1" x 1.25" x 4.5"	13.5625"	41	46	33	32
TC120315	1" x 1.25" x 5.1875"	13.5625"	47	50	39	39
TC120530	1" x 1.25" x 6.1875"	14.4375"	59	66	51	60
TC200115	1" x 1.25" x 4.5"	13.5625"	47	50	39	39
TC200330	1" x 1.25" x 5.1875"	14.4375"	58	65	50	59
TC200530	1" x 1.25" x 6.1875"	14.4375"	58	65	50	59

## 2TC SERIES 2 STAGE PUMPS

### High Head Stainless Steel Centrifugal Pumps

## 2TC Series

The 2TC Series pumps are engineered for applications that require higher head. These 2 stage pumps deliver smooth steady performance for a variety of industrial, commercial, and agricultural applications.

The quality and performance you expect, along with industry best lead times and personalized service, only from Webtrol!



#### Features and Benefits

- 304 stainless steel pump case, motor bracket and impeller
- Close coupled design
- Centerline discharge
- Non-overloading motor rated for continuous duty
- High operating efficiency
- Back pullout design allows for ease of servicing
- Mechanical seal for maximum reliability

#### Performance

HP Range: 2 to 5 HP, 60Hz  
Capacities to 65 GPM  
Pressures to 107 PSI  
Temperature to 212 °F

#### Typical Services

- Deionized Systems
- Reverse Osmosis Systems
- Distribution Systems
- Car Wash Systems
- Liquid Transfer Systems
- Circulation Systems
- Pre-Filter Charge System
- Condensation Systems
- Cooling Tower Systems



There when you need us most

## 2TC Series

## 2TC SERIES FAMILY CURVES

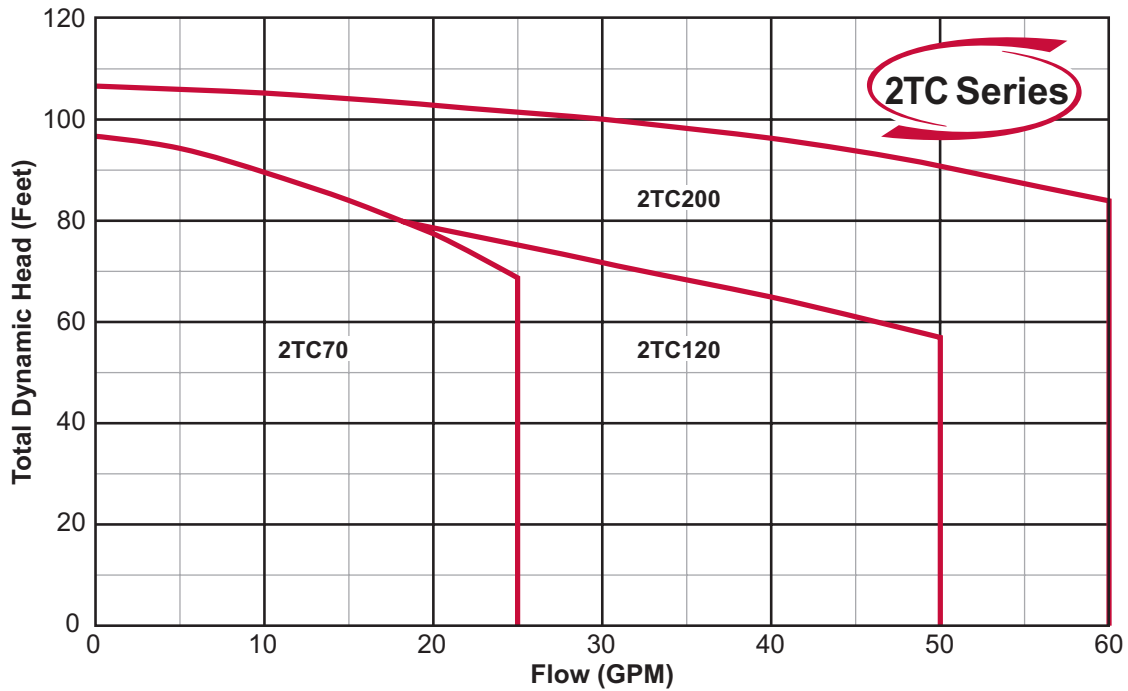

CONSTRUCTION MATERIALS	
Part	Material
Casing	304L SS
Impeller	304L SS
Shaft	304L SS
Bracket	Aluminum or Cast Iron
Mechanical Seal	Carbon/Ceramic

## 2TC SERIES Pump and Motor Dimensions

**2TC**Series

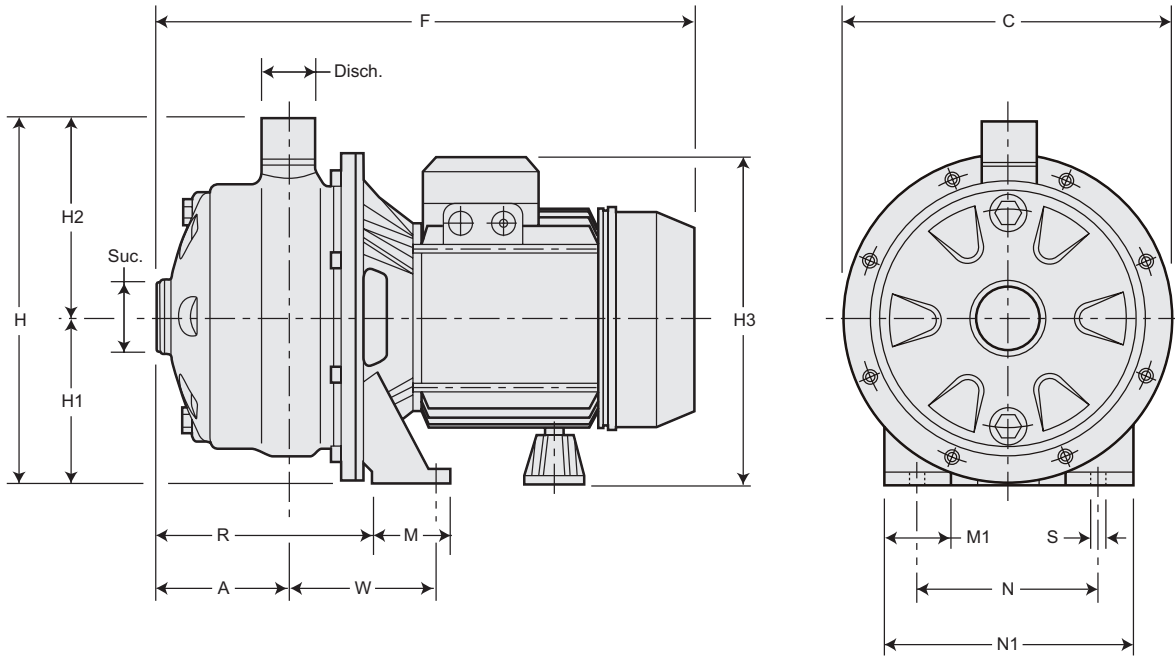

Model No.	Disch./ Suc. Frame	Motor Dimensions (in.)															
		HP	A	C	F	H	H1	H2	H3	M	M1	N	N1	R	S	W	Wt. Lbs.
2TC7020	1" x 1.25"	2	3.4375	9.125	14.9375	9.1875	4.625	5.1875	8.875	2.1875	1.5625	5.50	7.0625	5.50	0.375	3.75	42
2TC7030	1" x 1.25"	3	3.4375	9.125	14.9375	9.8125	4.625	5.1875	8.875	2.1875	1.5625	5.50	7.0625	5.50	0.375	3.75	44
2TC12030	1" x 1.25"	3	3.4375	8.1875	14.9375	9.0625	4.1875	4.875	8.4375	2.1875	1.5625	5.50	7.0625	5.50	0.375	3.75	35
2TC20050	1" x 1.5"	5.5	3.4375	9.125	17.375	9.1875	4.625	5.1875	9.5625	2.6875	1.9375	6.9375	1.9375	5.6875	0.50	4.3175	71



## SP SERIES SELF-PRIMING PUMPS

### Stainless Steel Centrifugal Pumps

## SP Series

The SP Series self-priming centrifugal pumps are designed to be installed above the water line, providing a suction lift of 25' and offer a superior alternative to standard cast iron jet pumps.

The quality and performance you expect, along with industry best lead times and personalized service, only from Webtrol!



#### Features and Benefits

- 304 stainless steel pump
- Close coupled design
- Centerline discharge
- Non-overloading motor rated for continuous duty
- High operating efficiency
- Back pullout design for ease of servicing
- Mechanical seal for maximum reliability

#### Performance

HP Range: .75 & 1.5 HP, 60Hz

Capacities to 19 GPM

Pressures to 90 PSI

Temperatures to 113 °F

#### Typical Services

- Home drinking water systems
- Deionized Systems
- Reverse Osmosis Systems
- Distribution Systems
- Misting Systems
- Car Wash Systems
- Liquid Transfer Systems
- Circulation Systems
- Pre-Filter Charge System
- Condensation Systems
- Cooling Tower Systems



There when you need us most

# SP Series

## SP SERIES FAMILY CURVES

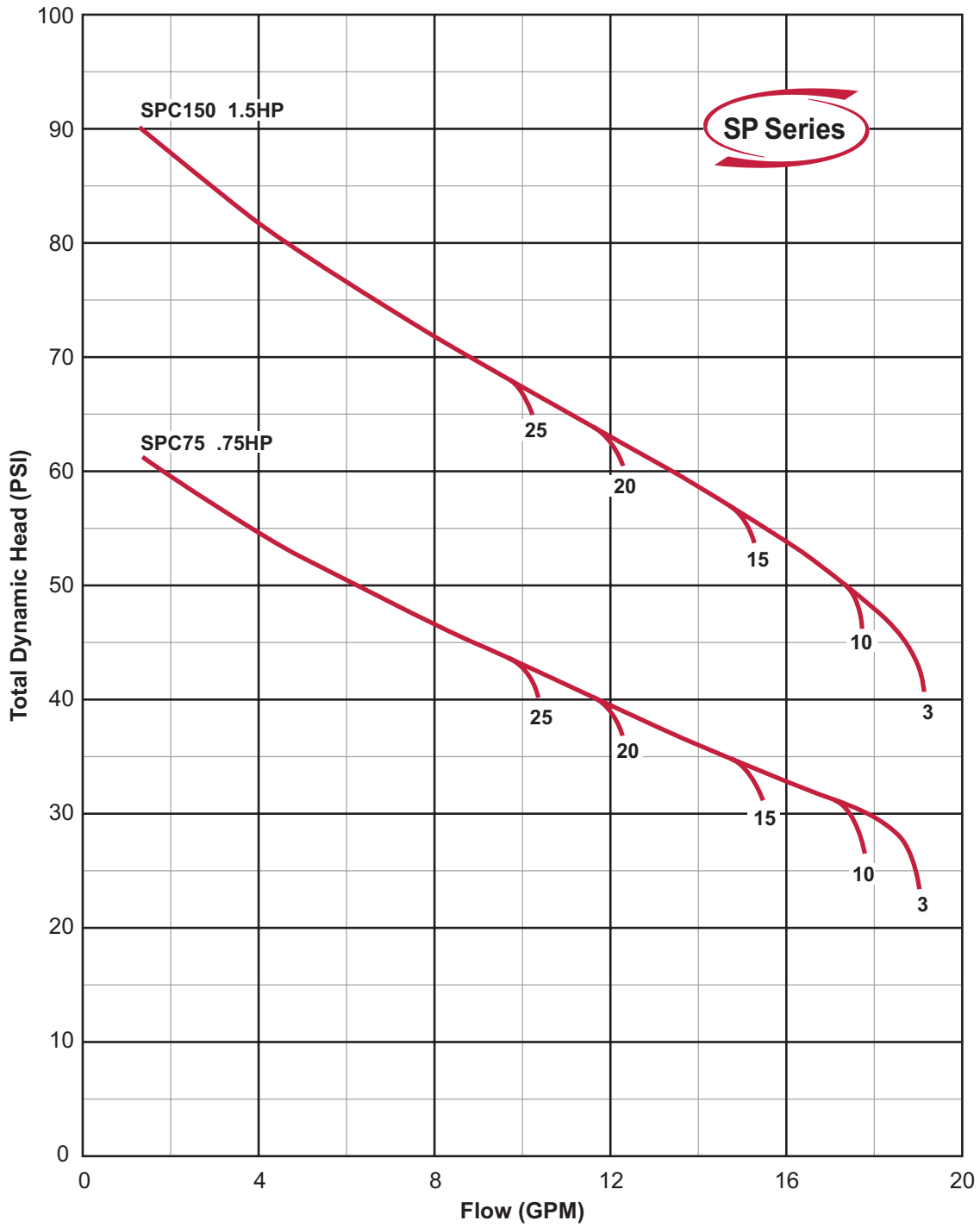





There when you need us most

## SP SERIES GROUP CURVES

**SP**Series

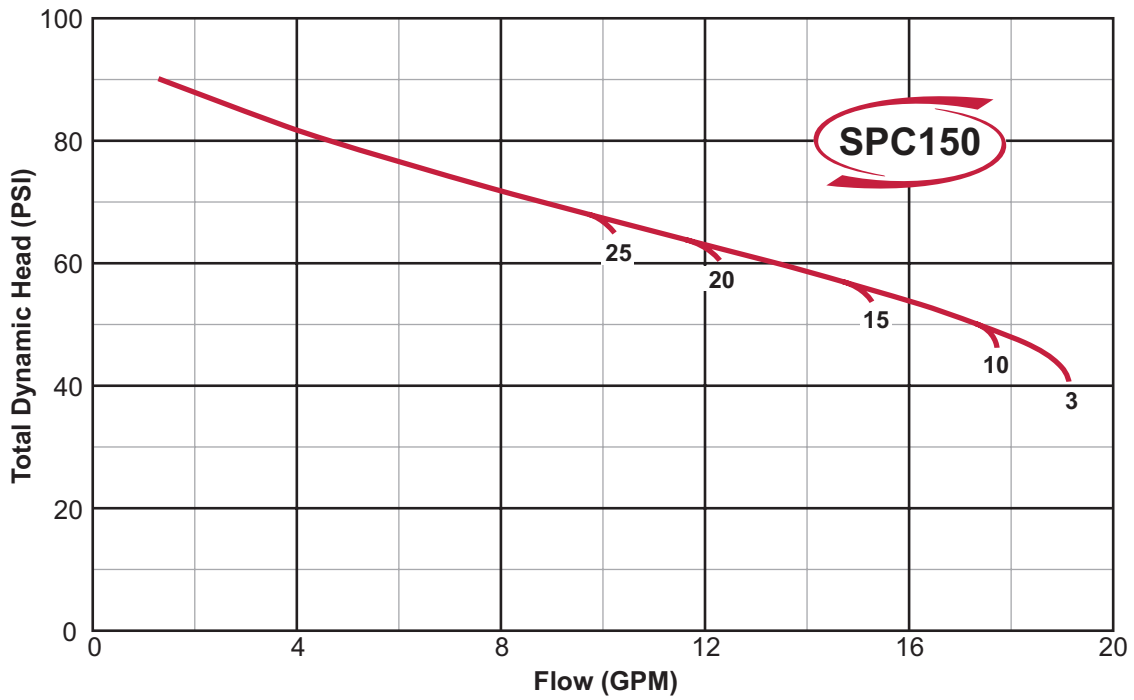
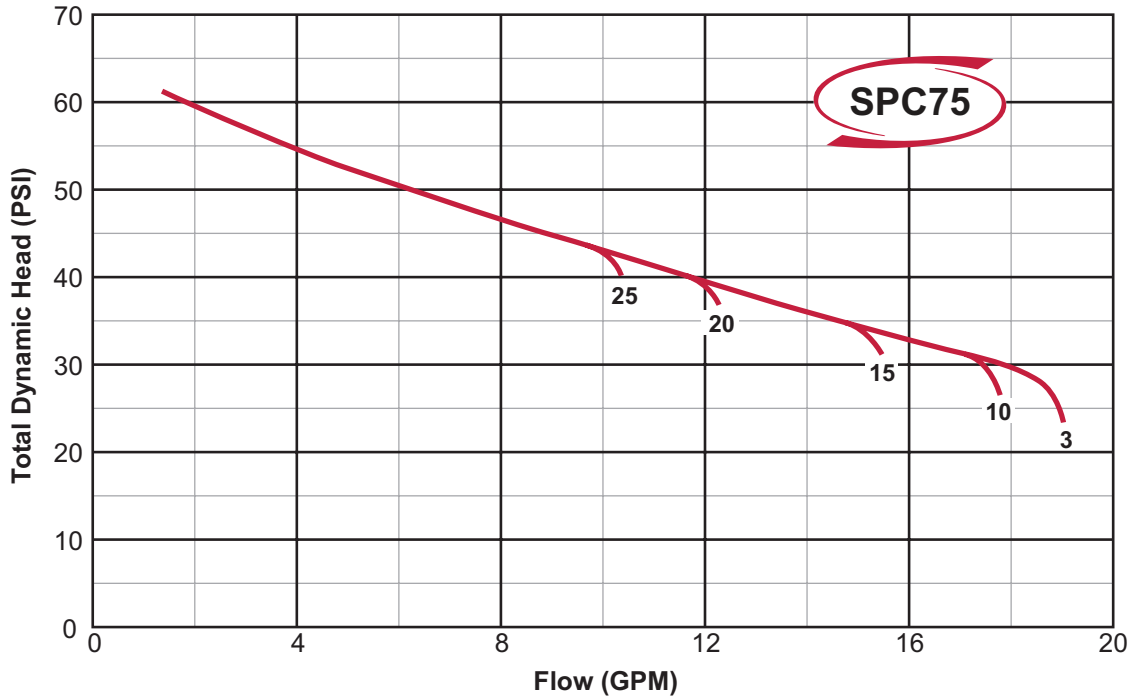

## SP Series

## SP SERIES FAMILY CURVES Pump and Motor Dimensions

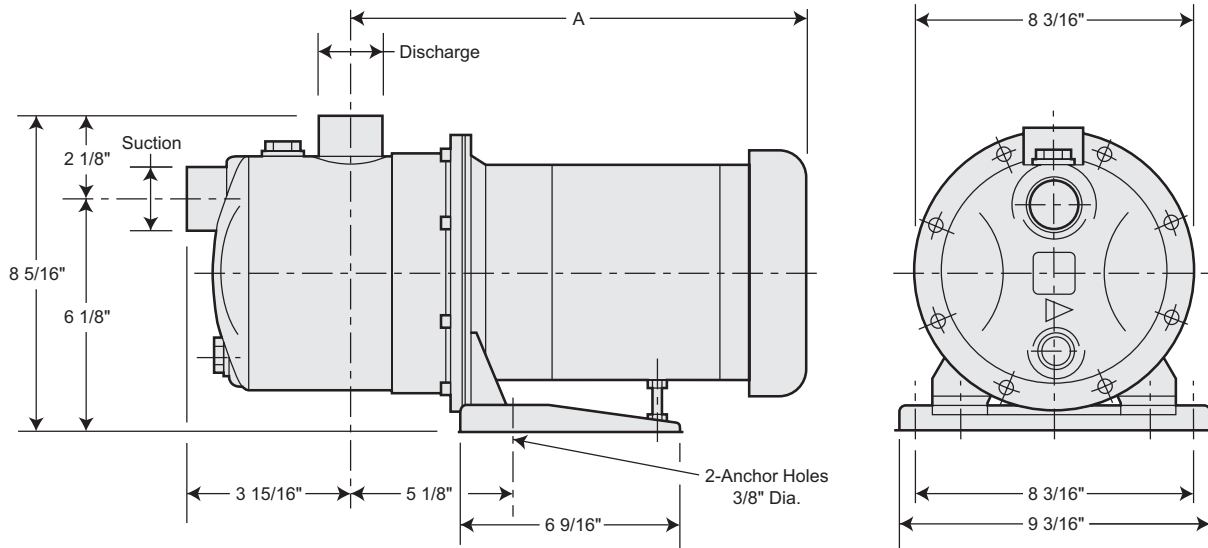

Model No.	Discharge / Suction/Imp. (inch-NPTF)	"A" Dimension	Single Phase Unit Weight (lbs.)		Three Phase Unit Weight (lbs.)	
			ODP	TEFC	ODP	TEFC
SPC75	1" x 1.25" x 4.5"	15.125"	37	41	39	43
SPC150	1" x 1.25" x 5.1875"	15.5625"	42	46	44	48

CONSTRUCTION MATERIALS	
Part	Material
Casing	304 SS
Impeller	304 SS
Shaft	Stainless Steel
Mechanical Seal	Carbon/Ceramic

## EP SERIES STAINLESS STEEL SUMP PUMPS

304 Stainless Steel

### Series

The EP Series offer you a complete and comprehensive range of submersible drainage pumps for pumping slurry, dirty and semi-dirty water.

The quality and performance you expect, along with industry best lead times and personalized service, only from Webtrol!



#### Features and Benefits

- 304 stainless steel construction
- Built in thermal overload with automatic reset
- Air filled, continuous duty rated motor
- Oil lubricated double faced mechanical seal
- 10' power cord on single phase models, 20' cords on three phase models.

#### Performance

HP Range: .33 - 1.5 HP, 60Hz.

Capacities to 90 GPM

Heads to 62'

Temperatures to 122 °F continuous  
or 140 °F intermittent

#### Typical Services

- Dewatering
- Waterfalls
- Water Transfer
- Fountains
- Sump Applications

## EP Series

## EP SERIES FAMILY CURVES

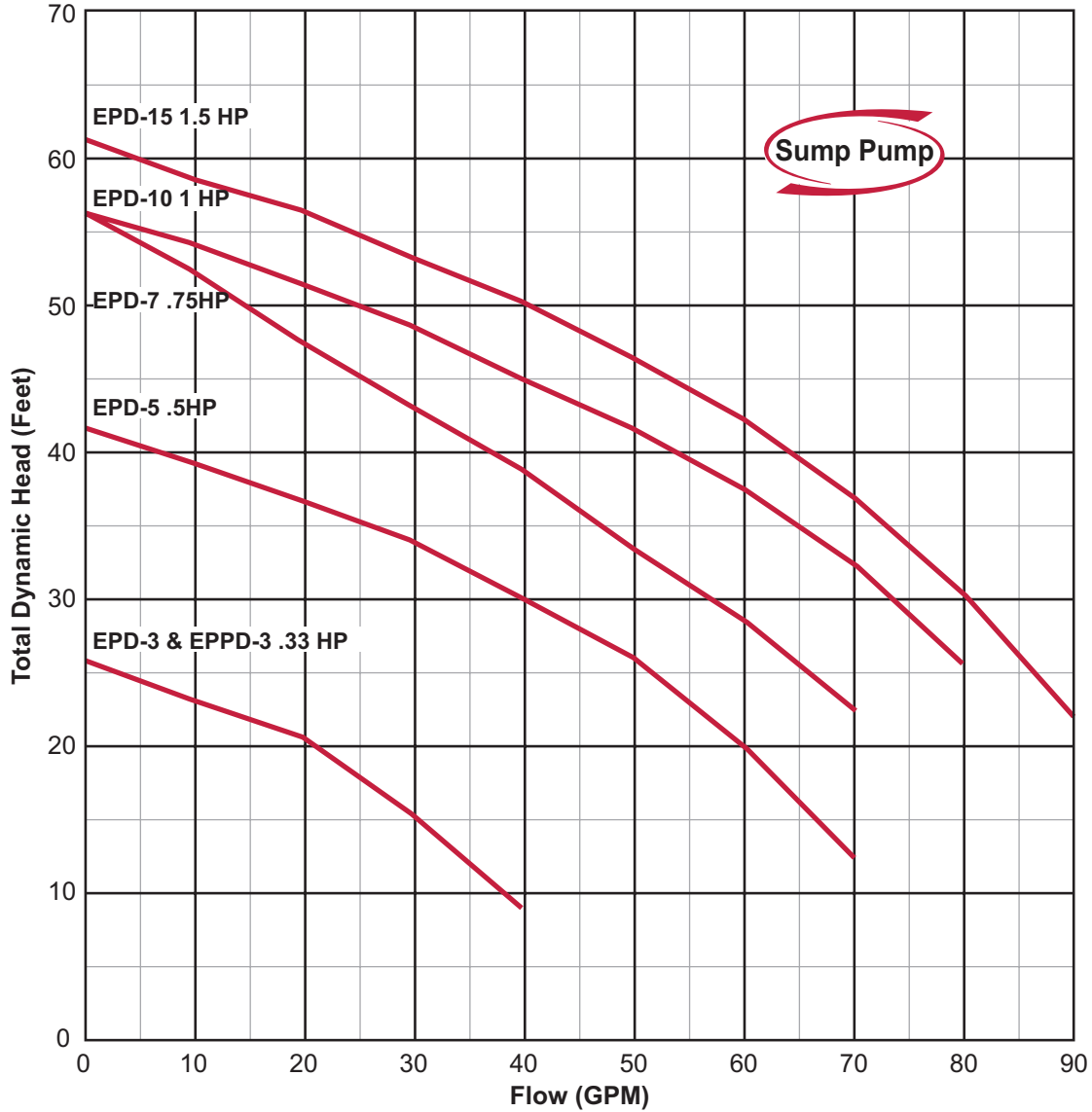

CONSTRUCTION MATERIALS	
Part	Material
Casing	304 SS
Impeller	304 SS
Shaft	303 SS
Motor Frame	304 SS
Fastener	304 SS
Double Shaft Seal - Upper	NBR Fitted Carbon/Ceramic
Double Shaft Seal - Lower	Viton™ Fitted Silicon Carbide/Silicon Carbide
Bearing	Sealed Ball Bearing

## EP SERIES GROUP CURVES Installation and Dimensions

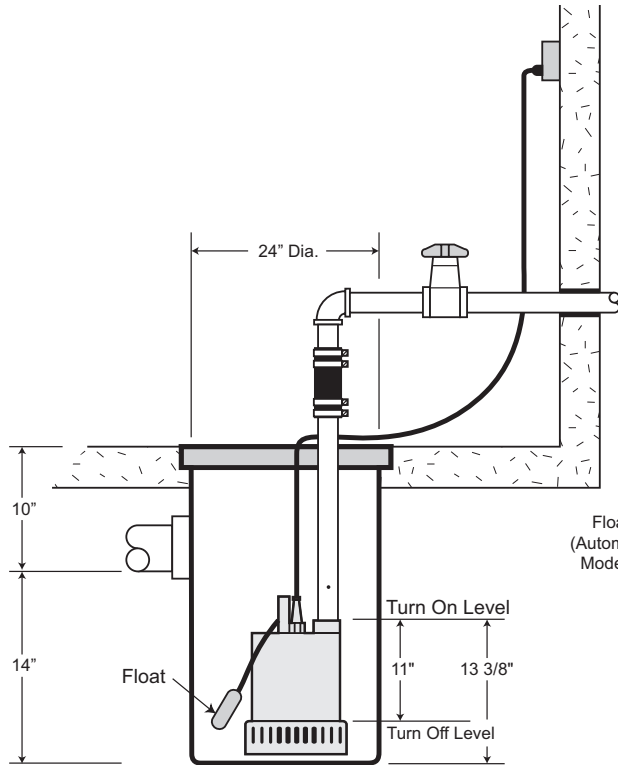

Typical Installation Automatic Models

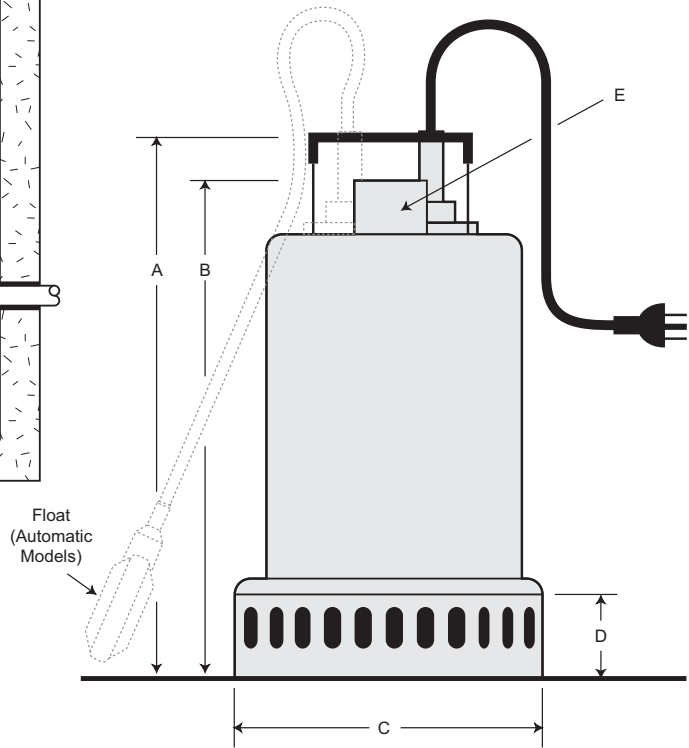

Dimensions For Automatic & Manual Models

Model No.	HP	Pump and Motor Dimensions (inches)					Cable Length (ft.)
		A	B	C	D	E	
EPPD-3AS1	1/3	10.25	8.0625	6.375	2.375	1.25	20
EPPD-3MS1	1/3	10.25	8.0625	6.375	2.375	1.25	20
EPD-3AS1	1/3	10.25	8.0625	6.375	2.375	1.25	20
EPD-3MS1	1/3	10.25	8.0625	6.375	2.375	1.25	20
EPD-5AS1	1/2	17.1875	13.625	8.25	2.375	1.5	20
EPD-5MS1	1/2	17.1875	13.625	8.25	2.375	1.5	20
EPD-5MT2	1/2	13.875	12.375	8.25	2.375	1.5	20
EPD-5MT4	1/2	13.875	12.375	8.25	2.375	1.5	20
EPD-7AS1	3/4	17.1875	13.625	8.25	2.375	1.5	20
EPD-7MS1	3/4	17.1875	13.625	8.25	2.375	1.5	20
EPD-7MT2	3/4	13.875	12.375	8.25	2.375	1.5	20
EPD-7MT4	3/4	13.875	12.375	8.25	2.375	1.5	20
EPD-10MT2	1	14.1875	13.375	8.25	2.375	1.5	20
EPD-10MT4	1	14.1875	13.375	8.25	2.375	1.5	20
EPD-15MT2	1 1/2	14.1875	13.375	8.25	2.375	1.5	20
EPD-15MT4	1 1/2	14.1875	13.375	8.25	2.375	1.5	20



## SS SERIES STAINLESS STEEL SEWAGE PUMPS

304 Stainless Steel

### **SS** Series

The SS Series is designed for efficient and reliable handling of sewage or waste water containing suspended solids up to 2" in diameter.

The quality and performance you expect, along with industry best lead times and personalized service, only from Webtrol!



#### **Features and Benefits**

---

- 304 stainless steel construction
- 2" solids handling
- High service factor motor design
- 2 pole, dry-submerged continuous duty rated motor type
- Double Viton™ mechanical seal
- Shielded ball bearings last 50,000 hours
- Automatic & manual operation
- 2" threaded or flanged discharge
- Max emersion depth of 33'
- 25' power cord

#### **Performance**

---

HP Range: .5 - 2 HP, 60Hz.

Capacities to 200 GPM

Heads to 65'

Temperatures to 104 °F continuous  
or 140 °F intermittent

#### **Motor**

---

Air filled motor with class F insulation with built in overload protection

#### **Typical Services**

---

- Commercial
- Industrial
- Agricultural



There when you need us most

**SS Series**

## SS SERIES FAMILY CURVES Single Channel and Vortex / Non-Clog Impeller

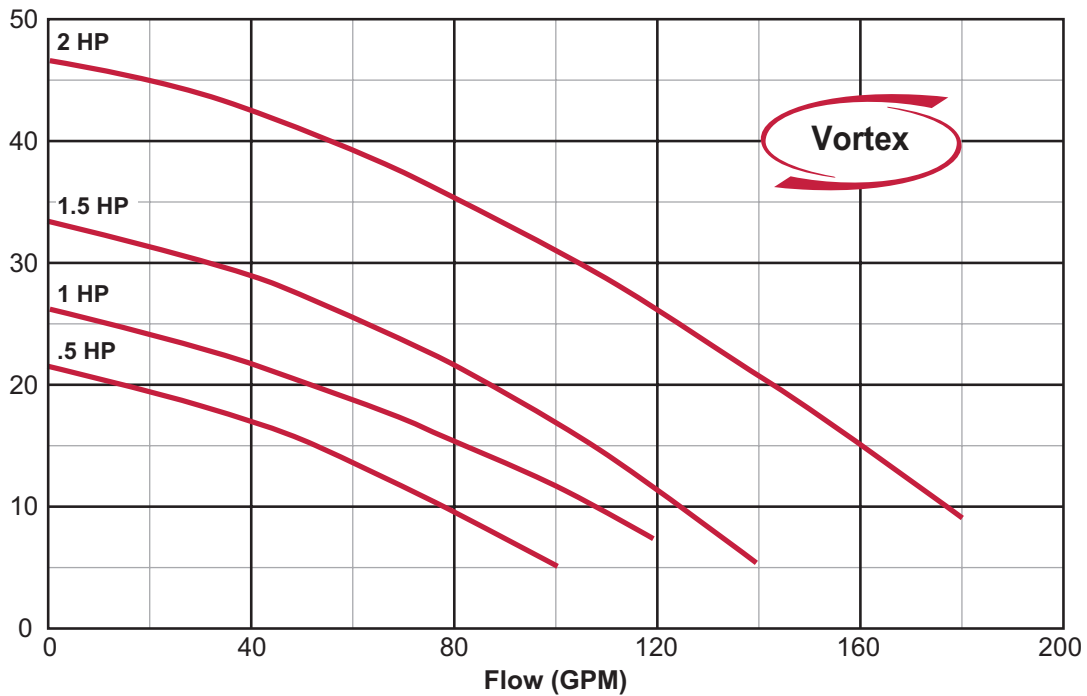
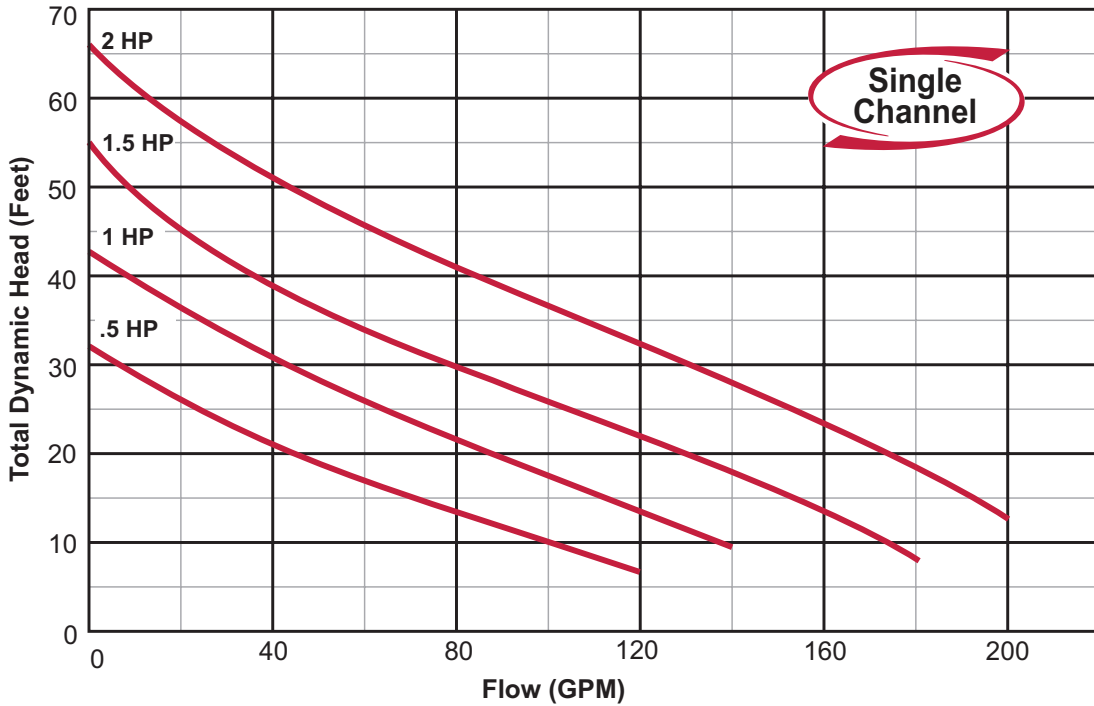



## SS SERIES GROUP CURVES Construction Materials



CONSTRUCTION MATERIALS	
Part	Material
Casing	304 SS
Impeller	304 SS
Shaft	304 SS
Motor Frame	304 SS
Fastener	304 SS
Double Mechanical Seal - Upper Side	Carbon
Double Mechanical Seal - Lower Side	Silicon Carbide

### Pump and Motor Dimensions

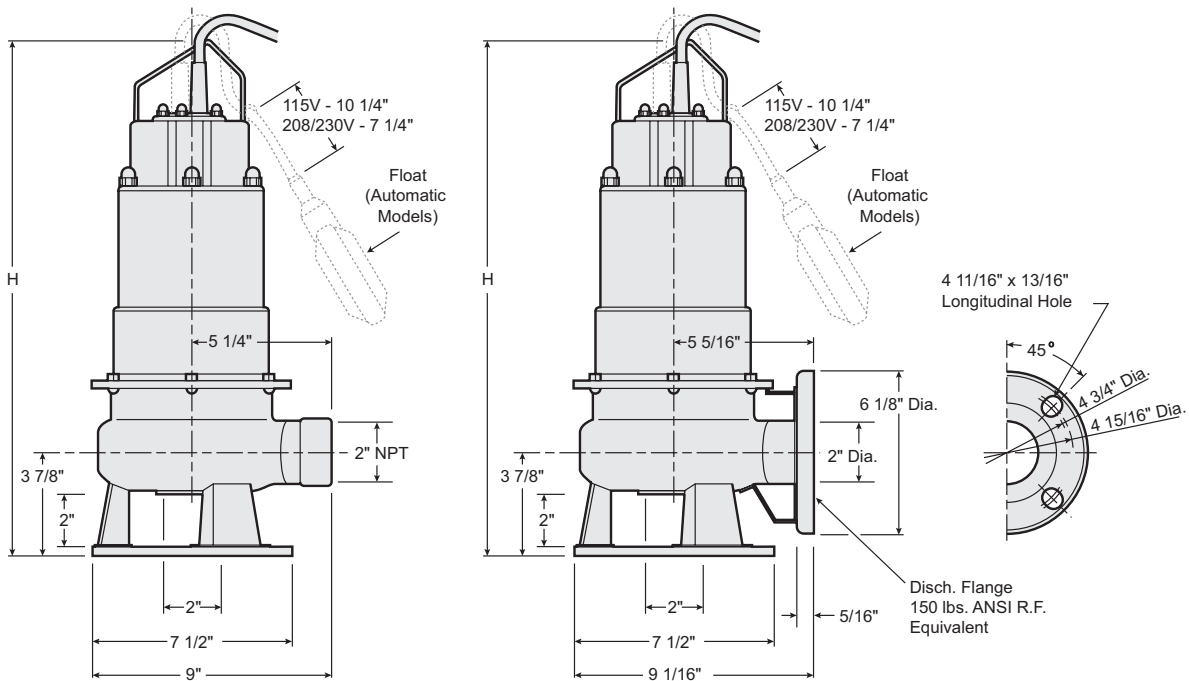

Phase	HP	Height (H) in.
Single	1/2	21.625
Single	1	22.875
Single	1 1/2	22.25
Single	2	24.0
Three	1/2	19.125
Three	1	19.125
Three	1 1/2	20.25
Three	2	20.25



There when you need us most

## LIMITED WARRANTY

### INDUSTRIAL PUMPS

#### Industrial Pump Limited Warranty

Weber Industries, warrants any product of its own manufacture to be free of defects in material and workmanship under normal use and services for the period shown. Weber Industries, Inc. obligation under this warranty is limited to repairing or replacing, at Weber Industries sole discretion, any defective pump found to Weber Industries' reasonable satisfaction to have been so defective upon examination of it, provided such pump is returned, freight prepaid, to Weber Industries' factory, in St. Louis, Missouri, or such other place as Weber Industries shall designate, within 30 days of failure date. Weber Industries, Inc. shall not be responsible for the removal or the reinstallation of any product covered under this warranty or any charges associated with the removal or reinstallation.

This warranty does not cover; Pumps returned for warranty that inspect and test within specifications; Pumps that have failed due to misuse or misapplication; Pumps that have been run in one of the following conditions; run dry, closed discharge head, liquids in excess of 140 degrees fahrenheit, liquids other than potable water, that have not been preapproved, in writing, by Weber Industries. This warranty does not cover power cable, lead wires, electrical components, control boxes or accessories of any kind.

Weber Industries, Inc. specifically limits the duration of any state law implied warranty of merchantability or fitness for a particular purpose to the time listed under the heading " PERIODS OF LIMITED WARRANTY ".

Except as provided in the foregoing warranty, Weber Industries, Inc. shall not be liable for any damage or loss to persons or property, including without limitation, consequential damages for breach of any written or implied warranty covering any product manufactured by Weber Industries, Inc.

#### Periods of Limited Warranty

The following series Webtrol Pumps are warranted to be free of defects in material and workmanship for a period of one year from the date of manufacture, when purchased as a complete unit consisting of motor and pump assembled together;

**EZ Series Boosters;**  
**HT Series Boosters;**  
**In-Line Series Boosters;**  
**PC Series Centrifugals;**  
**Stainless Steel Series Centrifugals;**  
**Cast Iron Series Centrifugals;**  
**Sump Pumps Plastic Base Series;**  
**Vertical Series Boosters, Stainless Steel;**

Weber Industries, Inc. does not warrant any part not manufactured by it, but assigns to buyer, Weber Industries' rights under any warranty given by the manufacturer of such part.

Pumps not manufactured by Weber Industries but supplied by Weber Industries;

**Sewage Pumps Stainless Steel Series;**  
**Sump Pumps Stainless Steel Series;**

**Motor And Controls:** 12 months from date of manufacture, when purchased as a complete unit consisting of a pump and motor assembled together by Weber Industries, Inc. This warranty is coextensive with the original manufacturer warranty against electrical and mechanical defects.

**There is no warranty on individual components when purchased for the above described series of pumps, when not factory installed by Weber Industries. When factory installed, components will be warranted for a period of 90 days from date of repair.**

**For all other products not listed, consult factory for warranty information.**

The warranty set forth above is made expressly in lieu of any other express warranties. The warranty set forth above shall be designated as a **Limited Warranty** within the meaning of title 15, S2303 of the United States Code.



There when you need us most

## CONDITIONS OF SALE

**Acceptance Of Orders:** All orders and contracts are subject to acceptance by the management of Weber Industries, Inc. (the company) and to the conditions herein set forth.

**Prices:** Merchandise, prices, discounts, quotations, freight policy and specifications are subject to change without notice and will be applied as in effect at the time of shipment. Prices shown do not include any sales, excise or other government charges payable by seller to Federal, State or local authority. Buyer agrees to reimburse Seller for any such tax or provide Seller with acceptable tax exemption certificate.

**Routing:** On FOB factory shipments, customers' choice of routing will be followed if specified whenever practical. On prepaid shipments, we reserve the right to specify routing.

**Terms And Interest Charges:** Except as otherwise indicated, payment is due in United States of America currency, 30 days after date of invoice on approved credit. A 1 1/2% monthly service charge; as indicated on every invoice, will be assessed on all invoices which remain unpaid past 30 days from date of invoice. Any of the terms and provisions on the customers' order which are in any way inconsistent with our policy shall not be considered applicable to the sale. The customer will be responsible for any and all cost incurred, including attorney fees and court cost, in the collection of any and all delinquent invoices and or service charges.

**Minimum Billing:** The minimum charge for any order will be \$25.00 net, exclusive of tax or transportation charges, except on purchases of sales aids.

**Shipment:** Prompt shipping dates are based on full and complete information at the factory and credit approval. Shipment of phoned orders before receipt of written confirming purchase orders shall be at customers risk.

**Design:** Weber Industries reserves the right at any time, to discontinue the manufacture or distribution of any model, or to make changes in the design of manufactured products or distribute improved products without incurring any obligation to replace, furnish, install or upgrade products previously supplied.

**Cancellation:** No orders or sales may be cancelled without the consent of Weber Industries, Inc. At the company's option, cancelled orders are subject to cancellation charges equal to all cost incurred by the company up to the date of cancellation, including a 10% charge for overhead. Special orders can not be cancelled.

**Return Of Goods:** Prior permission from Weber Industries, Inc. must be obtained before any goods may be returned and each item must be in it's original package, in like new condition, properly tagged or labeled with the company return goods authorization number. New and unused material, of current design, accepted and approved by the company for credit, is subject to a restocking charge of at least \$30.00 dollars or 25%, whichever is greater. In addition, in the case of an item not manufactured by Weber Industries, Inc., any and all cost for updating and/or restocking charges charged to Weber industries, Inc., by a vendor of Weber Industries, Inc. will be added to the restocking charge. Weber Industries, Inc will not take back electrical products that cartons have been opened or products that have been special ordered. Credit issued by Weber Industries, Inc. will be for the original purchase amount, not current replacement cost. Credits are non-refundable but may be used for the purchase of product common to your industry. **Freight; All transportation charges must be borne by the customer. No collect or C.O.D. shipments will be accepted.**

**Expedited Orders:** Expedited/Rush orders or rush warranty replacement orders are subject to an expediting charge to be determined by Weber Industries, Inc. In addition, all orders requiring Weber Industries, Inc. to use an intermediate transport mode such as a cab or messenger to get a product to a bus, airline or truckline, will be subject to an extra delivery charge in addition to any other freight charges from the delivering carrier.

**Repairs:** Both in warranty and out of warranty material will be repaired or replaced, at the sole discretion of Weber Industries, Inc. and shipped within a reasonable period of time, after receipt at factory if properly tagged or labeled with the company return goods authorization number. Warranty will be based on factory inspection of returned merchandise as outlined in Webtrol's Limited Warranty. If the product being returned is found to be out of warranty, you will be notified. If you elect to have the, out of warranty product inspected, there will be a charge for inspection, to be determined by Weber Industries, Inc. The inspection fee will be waived, if the product is repaired. All material must be shipped to the Webtrol factory or such place as Weber Industries, Inc. shall designate, via prepaid freight. Any credit issued for warranty material will be for the original purchase amount, not current replacement cost. Credits are non-refundable but may be used for the purchase of product common to your industry. All material will be returned FOB.

**NOTE:** Used septic and sewer products being returned for warranty determination must be thoroughly cleaned and chlorinated before returning or a cleaning charge of \$30.00 will be accessed.

**Delayed Deliveries:** Weber Industries, Inc. shall not be liable for any delay in shipping or delivery of merchandise for any reason whatsoever. If for any reason whatsoever, merchandise ordered is not accepted by the applicable public carriers, the company shall have the right to deliver said merchandise to a bonded warehouse for storage at the expense of the purchaser, and such delivery shall be conclusively deemed delivered of such merchandise to purchaser.

**Substitutions:** Weber Industries, Inc. reserves the right to substitute materials and modify specifications to the extent required in order to comply with any governmental law or regulation.

**Sales Policy:** Nothing herein shall be construed as abridging the right of Weber Industries, Inc. to sell directly or indirectly to 1.) Federal or State Governments; 2.) Purchasers' who buy company products for sale as integral or assembled parts of their products; 3.) Firms operating on a national scale; 4.) Any other class of purchaser to whom the company may from time to time elect to sell directly.

**Conditions:** All sales made by Weber Industries, Inc. are subject to these conditions unless otherwise agreed to in writing and signed by a duly authorized officer of the company. In all cases of conflict between these conditions and the requirements of the purchase order, these conditions shall prevail. All sales shall be governed by Missouri law. All disputes arising between you and Weber shall be litigated solely in the Circuit Court of St. Louis County, Missouri as the mutually agreed forum.



*There when you need us most*

**(800) 769-7867**

8417 New Hampshire Ave. | St. Louis, MO 63123

**Web:** [webtrol.com](http://webtrol.com) | **E-mail:** [customerservice@webtrol.com](mailto:customerservice@webtrol.com) | **Fax:** (314) 631-3738

*WEBTROL* is a Division of Weber Industries, Inc.